

AQ-110F

Arc sensor device with overcurrent

Instruction manual

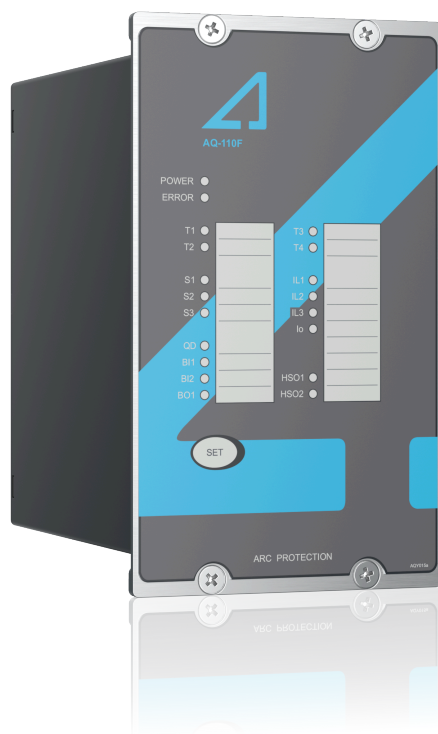

Table of contents

1 Document information	4
2 Safety information	7
3 Abbreviations	8
4 General	9
5 Device features	10
6 Connections	11
6.1 Inputs	12
6.1.1 Current transformer measurement inputs	12
6.1.2 Rogowski coil measurement inputs	13
6.1.3 Arc sensor channels	14
6.1.4 Binary inputs	14
6.2 Outputs	15
6.2.1 Binary outputs	15
6.2.2 High-speed output(s)	15
6.2.3 Trip relays	16
6.2.4 System failure relay	16
6.3 Auxiliary voltage	17
7 Arc sensors	18
7.1 Arc light fiber optic loop sensor AQ-06	18
7.2 Arc light fiber optic loop sensor AQ-07	18
7.3 Arc light fiber optic loop sensor AQ-08	18
7.4 Sensor dependencies	19
8 Operation and configuration	20
8.1 Current threshold settings	20
8.2 DIP switch settings	20
8.3 Logic schemes	25
8.3.1 SS:0a Selective arc protection	26
8.3.2 SS:1a Selective arc protection	29
8.3.3 SS:1b Selective arc protection	32
8.3.4 SS:2a Selective arc protection (recommended)	35
8.3.5 SS:2b Selective arc protection	38
8.4 Push button (SET)	40
8.4.1 System setup (auto-configuration)	41
8.4.2 Reset	41
8.4.3 Input connection check	41
8.5 Circuit breaker failure protection	42
8.6 LED indicator functions	42
8.7 LED operations guide	42
8.8 Modbus communication	43
8.9 Non-volatile memory	48
9 System self-supervision	49
10 Dimensions and installation	50
11 Testing	53
11.1 Testing the light-only mode	53
11.2 Testing the light and current mode	53
11.3 Testing the CBFP function	54
11.4 Testing the operation time	54
11.5 Test plan example	54
12 Troubleshooting	56

13 Technical data	57
13.1 Mounting and installation	57
13.2 Operating times	58
13.3 Auxiliary voltage	58
13.4 Current measuring circuits	58
13.5 Rogowski coil measurement inputs	59
13.6 Binary inputs	59
13.7 Trip relays	59
13.8 High-speed output(s)	60
13.9 Binary output(s)	60
13.10 System failure relay	60
13.11 Fiber optic loop sensors	61
13.12 Disturbance tests	62
13.13 Voltage tests	62
13.14 Mechanical tests	62
13.15 Environmental conditions	62
13.16 Casing	63
14 Ordering information	64
15 Contact and reference information	66

Disclaimer

Please read these instructions carefully before using the equipment or taking any other actions with respect to the equipment. Only trained and qualified persons are allowed to perform installation, operation, service or maintenance of the equipment. Such qualified persons have the responsibility to take all appropriate measures, including e.g. use of authentication, encryption, anti-virus programs, safe switching programs etc. necessary to ensure a safe and secure environment and usability of the equipment. The warranty granted to the equipment remains in force only provided that the instructions contained in this document have been strictly complied with.

Nothing contained in this document shall increase the liability or extend the warranty obligations of the manufacturer Arcteq Relays Ltd. The manufacturer expressly disclaims any and all liability for any damages and/or losses caused due to a failure to comply with the instructions contained herein or caused by persons who do not fulfil the aforementioned requirements. Furthermore, the manufacturer shall not be liable for possible errors in this document.

Please note that you must always comply with applicable local legislation and regulations. The manufacturer gives no warranties that the content of this document is in all respects in line with local laws and regulations and assumes no liability for such possible deviations.

You are advised to notify the manufacturer in case you become aware of any errors in this document or of defects in the equipment.

The manufacturer reserves the right to update or amend this document at any time.

Copyright

Copyright © Arcteq Relays Ltd. 2025. All rights reserved.

1 Document information

Table. 1 - 1. History of Revision 1.

Revision	1.00
Date	October 2010
Changes	- The first revision of the manual.
Revision	1.01
Date	July 2011
Changes	<ul style="list-style-type: none"> - Sensor chapter revised (fiber pictures and point sensor connections). - Standard Arc Scheme chapter revised (e.g. scheme 0a added). - DIP switch definition updated (e.g. HSO latch/non-latch). - LED description revised (current channels LEDs will not blink during the auto-configuration). - Partly AQ-110F information added. - Dimensions and installation chapter, the depth of the unit is changed from 170 mm to 175 mm. - Casing and dimensions section, the unit size and the size with package have been added.
Revision	1.02
Date	April 2012
Changes	- The AQ-SAS TM chapter removed from the manual.
Revision	1.03
Date	July 2012
Changes	<ul style="list-style-type: none"> - Scheme select DIP switch settings chapter added. - The point sensor max. wiring length is up to 200 meters. - System self-supervision chapter revised.
Revision	1.04
Date	May 2019
Changes	<ul style="list-style-type: none"> - Moved the scheme selection content to DIP switch settings, refer to Chapter 3.5. - Technical data updated. - Added an application example, refer to Chapter 6.
Revision	1.05
Date	November 2019
Changes	- Added information to the "Technical data" chapter.

Table. 1 - 2. History of Revision 2.

Revision	2.00
Date	October 2020

Changes	<ul style="list-style-type: none"> - Content completely rewritten to improve grammar and readability. - The "Available logic schemes" chapter updated. - The AQ-02 point sensor chapter added to the "Arc sensors" chapter, and AQ-02's technical data added to the "Technical data" chapter. - The sensor-unit type dependency list updated. - The original "Connecting sensors" chapter moved to the AQ-0x instruction booklet, and replaced with a summary of how to connect point sensors. A summary of connecting fiber sensors also added to the chapter. - All technical data checked and updated where necessary. - Ordering information updated. - Images updated where necessary.
Revision	2.01
Date	November 2021
Changes	<ul style="list-style-type: none"> - Panel cut-out installation image added. - Dimension measurements updated. - Replaced "one fifths" with "1 A or 5 A secondary nominal can be selected" in the "Unit features" chapter. - Wiring diagram, simplified block diagram, DIP switch diagram & application image(s) updated. - Push button image added. - End covering description added to AQ-07, removed from AQ-08. - Cut-and-slice text removed all fiber descriptions. - Connections image updated. - The test plan example updated. - The Main-Tie-Main application example image updated. - The HSO chapter updated. - All table layouts unified in "Technical data". - The IP classification of point sensors updated. - The AWG value updated. - "Disturbance tests" table reformatted. - Order code images updated (separated the codes for AQ-110P and AQ-110F). - The number for Arcteq's technical support added to the reference information.
Revision	2.02
Date	January 2023
Changes	<ul style="list-style-type: none"> - Updated the Arcteq logo on the cover. - Updated the distance between the flash and the sensor in the "Testing the operation time" chapter. - Unified terminology used throughout the manual (e.g. unit and device means the same thing. Now all AQ 100 series relays are called "devices"). - Improved many existing drawings. - Rearranged topics into a more logical order. - Added connection drawings to input and output descriptions under "Connections" chapter. - Added hyperlinks to chapters. (e.g. "See Device features chapter for more information") - Listed more features in Device features chapter. - T3 is now considered to be normally open by default and normally closed as an order option. - Added information about binary output pulse messages. - Many tables have been simplified and made easier to read. - Scheme matrixes and simplified logic diagrams have been made more detailed in the Available logic scemes chapter.
Revision	2.03
Date	April 2023

Changes	- Small changes to visual style. - Small improvements to descriptions.
Revision	2.04
Date	September 2024
Changes	- Added point sensor dimensions .
Revision	2.05
Date	November 2024
Changes	- Split AQ-110P and AQ-110F into separate manuals.
Revision	2.06
Date	July 2025
Changes	- Rogowski addition → Changes to the contents as needed throughout the document.
Revision	2.07
Date	August 2025
Changes	- Updated the DIP switch descriptions . - Made the polarity of Rogowski coil connections clearer. - Added the technical data for the X3, X4 & X5 connectors when Rogowski inputs are used. - Updated the order code for AQ-110F.
Revision	2.08
Date	September 2025
Changes	- Updated the Modbus map in the Modbus communication chapter.

2 Safety information

This document contains important instructions that should be saved for future use. Read the document carefully before installing, operating, servicing, or maintaining this equipment. Please read and follow all the instructions carefully to prevent accidents, injury and damage to property.

Additionally, this document may contain four (4) types of special messages to call the reader's attention to useful information as follows:



NOTICE!

"Notice" messages indicate relevant factors and conditions to the the concept discussed in the text, as well as to other relevant advice.



CAUTION!

"Caution" messages indicate a potentially hazardous situation which, if not avoided, could result in minor or moderate personal injury, in equipment/property damage, or software corruption.



WARNING!

"Warning" messages indicate a potentially hazardous situation which, if not avoided, could result in death or serious personal injury as well as serious damage to equipment/property.



DANGER!

"Danger" messages indicate an imminently hazardous situation which, if not avoided, will result in death or serious personal injury.

These symbols are added throughout the document to ensure all users' personal safety and to avoid unintentional damage to the equipment or connected devices.

Please note that although these warnings relate to direct damage to personnel and/or equipment, it should be understood that operating damaged equipment may also lead to further, indirect damage to personnel and/or equipment. Therefore, we expect any user to fully comply with these special messages.

3 Abbreviations

AQD	– arc quenching device
BI	– binary input
BO	– binary output
CB	– circuit breaker
CBFP	– circuit breaker failure protection
CT	– current transformer
EPROM	– erasable, programmable read-only memory
HSO	– high-speed output
LED	– light emitting diode
LV	– low-voltage
MV	– medium-voltage
NC	– normally closed
NO	– normally open
PCB	– printed circuit board
RF	– radio frequency
Rx	– receiver
SAS	– standard arc scheme
SF	– system failure
Tx	– transceiver
μP	– microprocessor

4 General

The AQ-110F is a sophisticated microprocessor-based arc flash protection device with fiber loop sensor channels. The devices are designed to minimize the damage caused by an arc fault. This is done by tripping the circuit breaker which supplies current to the fault when sensors detect arc light.

The device has three phase current measurement channels and one residual current measurement channel. Rogowski coil current measurement inputs are also available as an ordering option. Fault current detection can be used as an additional trip criterion to confirm arc faults detected by light sensors.

The device includes a complete system self-supervision functionality which provides the highest level of dependability as it continuously monitors all internal system functions as well as all external connections.

The device can be ordered with an optional serial Modbus communication module, which can be used for receiving status reports from the device.

Figure. 4 - 1. Arc protection devices AQ-110F.



The AQ-110F is designed according to the latest protection relay standards and is therefore suitable for installations in rough environments. These include utilities and power plants (both traditional and renewable), various heavy industry applications (off-shore, marine, oil, gas, mining, steel, etc.) as well as commercial and institutional electrical systems. The device is suitable for MV and LV switchgears as well as for motor control center applications in both new and retrofitted installations.

5 Device features

AQ-110F is an arc flash protection device which can be applied to a variety of applications. The device can be used on its own as a stand-alone device, or as a part of a more complex arc protection system by using binary inputs and outputs to connect multiple AQ 100 series devices together.

The following list presents the main features of the AQ-110F device:

- 92...265 V AC/DC auxiliary power supply or 18...72 V DC auxiliary power supply
- three (3) phase current inputs and one (1) residual current input, either with standard CT inputs or with Rogowski inputs
- two (2) trimmers for configuring overcurrent function trip levels
- three (3) fiber loop sensor channels for arc flash detection
- one (1) fiber connector for arc quenching device control (optional)
- two (2) binary inputs
- two (2) high-speed semiconductor outputs (HSO)
- four (4) trip relays
- one (1) binary output
- one (1) system failure relay (change-over)
- nineteen (19) indication LEDs
- sixteen (16) DIP switches for logic configuration
- one (1) multifunction push button.

6 Connections

AQ-110F with standard CT inputs.

The figure below depicts the connections of AQ-110F with standard current inputs. Please note that the SF relay is in the de-energized position; also note that the device has been halved for the image to allow for space for all connector descriptions.

Figure. 6 - 2. Rear terminals of AQ-110F.

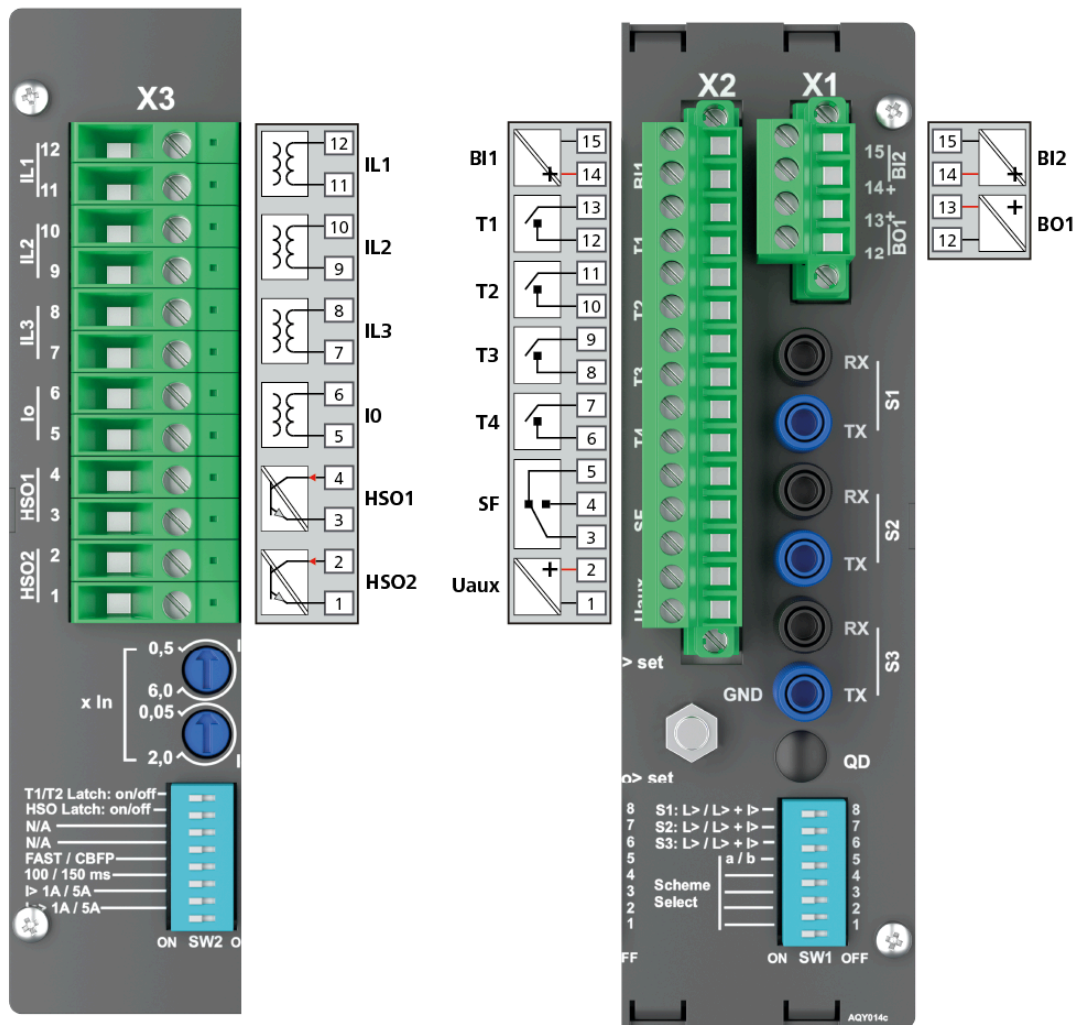

AQ-110F with Rogowski inputs.

The figure below depicts the connections of AQ-110F with Rogowski current inputs. Please note that the SF relay is in the de-energized position; also note that the device has been halved for the image to allow for space for all connector descriptions.

Figure. 6 - 3. Rear terminals of AQ-110F with Rogowski inputs and optional Modbus add-on.

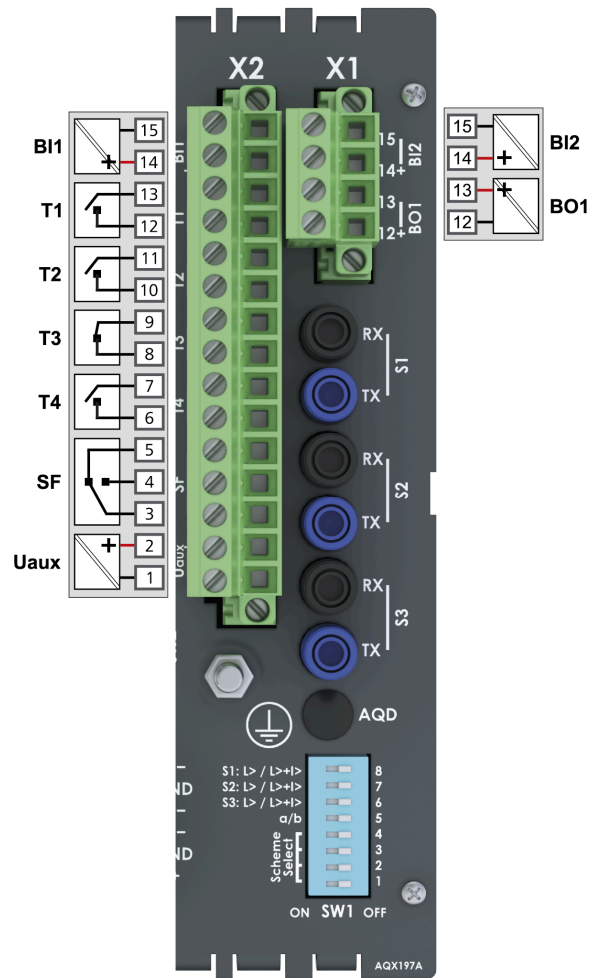

6.1 Inputs

6.1.1 Current transformer measurement inputs

Figure. 6.1.1 - 4. Current measurement connections.

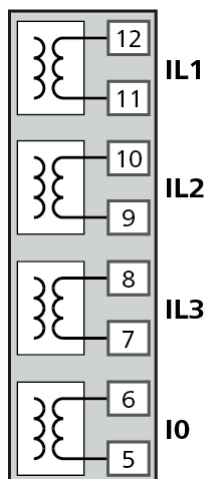

This device has four (4) CT inputs for measuring the three phase currents and the residual current. Both the phase current and the residual current inputs can be configured to a nominal current of 1 A or 5 A with the DIP switches (for more information, please refer to the [DIP switch settings](#) chapter).

The [Current threshold settings](#) chapter describes the setting of current threshold levels in more detail.

This device includes a current transformer supervision function. See the [System self-supervision](#) chapter for more information.

6.1.2 Rogowski coil measurement inputs

Figure. 6.1.2 - 5. Rogowski coil current measurement connections.

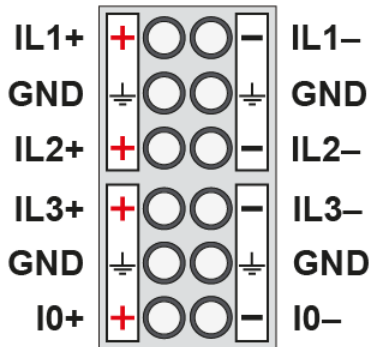

This device can be ordered with four (4) Rogowski coil current inputs for measuring the three phase currents and the residual current. With the DIP switches the RC selection can be set to OFF or one of following three levels: 22.5 mV/kA, 100 mV/kA, or 333 mV/kA. For more information on the DIP switches, please refer to the [DIP switch settings](#) chapter.

This device includes a current transformer supervision function. See the [System self-supervision](#) chapter for more information.

6.1.3 Arc sensor channels

Figure. 6.1.3 - 6. Arc fiber loop sensor and arc quenching device connections.

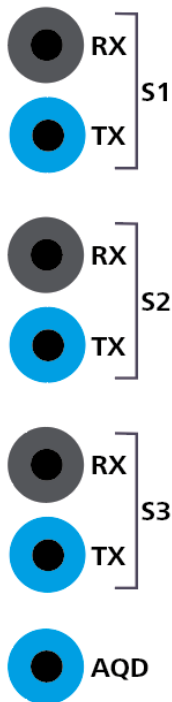

The device has three (3) fiber loop arc sensor channels: S1, S2 and S3. Each channel has a transmitter (Tx) terminal and a receiver (Rx) terminal. These sensor loops are continuously monitored by test light pulses that are sent by the "Tx" channel. If a discontinuity is detected, the device goes into Error mode. See the [System self-supervision](#) chapter for more information.

The device can be ordered with an additional transmitter (Tx) terminal for arc quenching device (AQD) control. Device sends a test light pulse continuously to the arc quenching device to supervise the fiber connection. If the arc quenching device doesn't receive the test pulses the device will go into Error mode. Alternatively, you can order the device where the input sensitivity of the three fiber loop sensors is low (please refer to the [Ordering information](#) chapter).

For more information on sensors, please refer to the [Arc sensors](#) chapter.

6.1.4 Binary inputs

Figure. 6.1.4 - 7. Binary input connections.

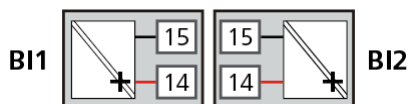

This device has two (2) binary inputs. Typically, the binary inputs are used for receiving arc light signals, master trip commands or overcurrent signals from other AQ 100 series devices. Function of binary inputs are configured using DIP switches. For more information, please refer to the [DIP switch settings](#) chapter.

The nominal voltage level of the binary inputs for this device is 24 VDC. Please note that the actual activation threshold of the binary input is at a lower voltage than the specified nominal voltage value (see the [Technical Data](#) chapter).

AQ 100 series devices are capable of monitoring health of wiring between binary inputs and binary outputs of other AQ 100 series devices in the system. If a binary input loses connection to any of the configured binary outputs, the device will go into Error mode. See the [System self-supervision](#) chapter for more information.

6.2 Outputs

6.2.1 Binary outputs

Figure. 6.2.1 - 8. Binary output connection.

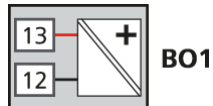

The device has one (1) binary output: BO1. This binary output is used for sending overcurrent, light detection, master trip and other signals to other AQ 100 series devices in the system. The binary output function can be configured with the DIP switches. For more information on the configuration, please refer to the [DIP switch settings](#) chapter.

AQ 100 series binary outputs have an internal 24 VDC power supply. Binary outputs generate a short test pulse every second. Binary inputs of the receiving AQ 100 series devices use these pulses to count the number of connected binary outputs and supervise the I/O connection. See the [System self-supervision](#) chapter for more information.



NOTICE!

Binary output is polarity-sensitive.

6.2.2 High-speed output(s)

Figure. 6.2.2 - 9. The high-speed output's direction of rotation.

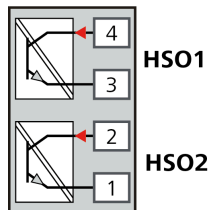

The device has two (2) high-speed semiconductor outputs, namely HSO1 and HSO2. These outputs can be used as heavy-duty signaling outputs. Due to their high current-carrying capacity, HSO1 and HSO2 can send overcurrent, light or master trip signals to a maximum of twenty (20) pieces of AQ 100 series devices without a need for signal amplifiers. The operation of these high-speed outputs depends on the DIP switch settings (for more information, please refer to the [DIP switch settings](#) chapter).

High-speed outputs generate a short test pulse every second. Binary inputs of the receiving AQ 100 series devices use these pulses to count the number of connected high-speed outputs and supervise the I/O connection. See the [System self-supervision](#) chapter for more information.

The output's direction of rotation is as follows: the signal goes in the even pin and out from the odd pin (see the image above).

**NOTICE!**

The high-speed outputs are polarity-sensitive.

6.2.3 Trip relays

Figure. 6.2.3 - 10. Trip relay connections

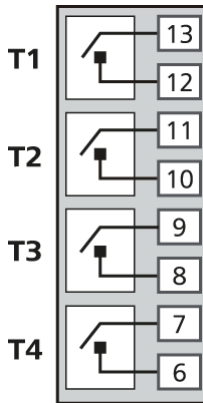

This device has four (4) normally open trip relays. Trip relays T1, T2 and T3 are generally used for tripping circuit breakers. T4 is generally used for tripping one additional disconnecting device, or as a trip alarm (local or remote) monitoring and alarming system.

T3 can alternatively be ordered as a normally closed relay (electronic lock-out relay). Once opened by fault detection it holds its open position until it receives a manual reset command or until auxiliary power supply is lost. When re-applying the auxiliary power supply, the electronic lock-out relay returns to the same position it had prior to the power loss. This normally closed relay can also be used for tripping contactor-controlled devices.

T3 and T4 are always latching relays. Trip relays T1 and T2 can be set as latching relays with a DIP switch setting (for more information, please refer to the [DIP switch settings](#) chapter).

6.2.4 System failure relay

Figure. 6.2.4 - 11. System failure relay connection (de-energized position)

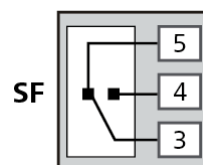

The system failure (SF) relay is of the change-over type (NO/NC) and it is energized when the device is in a healthy condition and powered on. Whenever the device detects a system error or the auxiliary power supply is disconnected, the SF relay changes its state. The state stays this way until the device returns to a healthy condition. See the [System self-supervision](#) chapter for more information.

6.3 Auxiliary voltage

Figure. 6.3 - 12. Auxiliary power supply connection

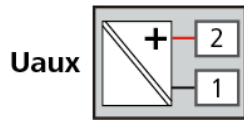

The auxiliary power supply voltage is 92...265 V AC/DC. Alternatively, the auxiliary power supply can be of 18...72 V DC. This choice must be specified when ordering.

7 Arc sensors

The AQ 100 series supports arc sensing point sensors and fiber optic loop sensors. These sensors can be used with different devices and different switchgear types according to specific application requirements.

Point sensors are typically installed in metal-clad compartments, and they provide a quick and accurate location of the fault area. Fiber loops typically cover a wider protected area with one fiber, when there is no need to pinpoint the exact location of a fault.

7.1 Arc light fiber optic loop sensor AQ-06

AQ-06 is an arc light fiber optic loop sensor, which is a plastic fiber optic cable. Fiber sensors are distributed through the protected switchgear cells. The light intensity threshold of an AQ-06 sensor is 8,000 lux. The sensor's detection radius is 360 degrees.

AQ-06 sensors can be ordered in pre-manufactured lengths of 3...40 meters (3 m, 5 m, 10 m, 15 m, 20 m, 25 m, 30 m, 35 m, 40 m).

7.2 Arc light fiber optic loop sensor AQ-07

AQ-07 is an arc light fiber optic loop sensor, which is a robust fiber optic cable with a practically unlimited bending radius. The sensor contains hundreds of glass fiber drains covered by a plastic tube, thus making it extremely strong and durable. Fiber sensors are distributed through the protected switchgear cells.

AQ-07 sensors can be ordered in pre-manufactured lengths of 3...50 meters (3 m, 5 m, 10 m, 15 m, 20 m, 25 m, 30 m, 35 m, 40 m, 45 m, 50 m).

The light intensity threshold of an AQ-07 sensor is 8,000 lux. The sensor's detection radius is 360 degrees.

If necessary, the ends of an AQ-07 cable can be ordered with heat shrinking tubing to avoid light detection outside the protected zone. The covered area can be one (1) or two (2) meters by default; if other lengths are required, please consult the Arcteq sales team. You can find the [Contact and reference information](#) chapter at the end of this manual.

7.3 Arc light fiber optic loop sensor AQ-08

AQ-08 is an arc light fiber optic loop sensor. It is designed to withstand temperatures up to 125 °C, which makes it suitable for e.g. wind turbine windings. AQ-08 is a robust fiber optic cable with a practically unlimited bending radius. The sensor contains hundreds of glass fiber drains that are covered by a plastic tube, thus making it extremely strong and durable. Fiber sensors are distributed through the protected switchgear cells.

AQ-08 sensors can be ordered in pre-manufactured lengths of 3...15 meters (3 m, 5 m, 10 m, 15 m).

The light intensity threshold of an AQ-08 sensor is 8,000 lux. The sensor's detection radius is 360 degrees.

7.4 Sensor dependencies

Compatibility of arc sensor types depend on the hardware available in the AQ 100 series device. The table below describes those dependencies.

Table. 7.4 - 3. Sensor dependencies.

	Point sensors (AQ-01 & AQ-02)	Fiber loops (AQ-06, AQ-07 & AQ-08)
AQ-101	Yes	Order option
AQ-101D	Yes	Order option
AQ-101S	Yes	No
AQ-102	No	Yes
AQ-103	Yes	Order option
AQ-110P	Yes	Order option
AQ-110F	No	Yes

8 Operation and configuration

8.1 Current threshold settings

The AQ-110x devices have four (4) current measurement inputs: three (3) measure phase currents and one (1) measures the residual current. Both the phase and residual current measurements can be used as an additional trip criteria in an arc protection system to avoid trips caused by natural light sources. When an arc sensor channel has been set to "Light and overcurrent" mode, overcurrent and light must be detected simultaneously for the device to trip.

Depending on the selected logic scheme the device can also send overcurrent indication signals with binary outputs or high-speed outputs to other AQ 100 series devices in the system.

Figure. 8.1 - 13. Current measurement DIP switches.

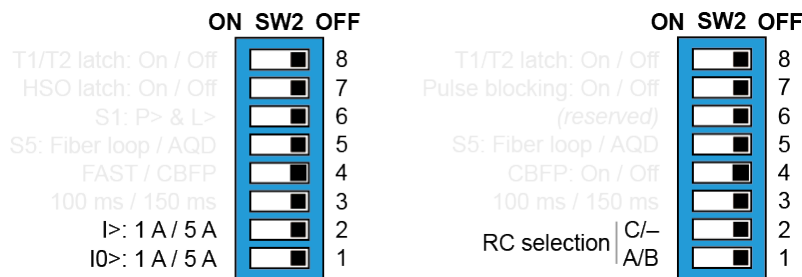

DIP switches SW2:1 and SW2:2 can be used for selecting either 1 A or 5 A nominal current for phase current measurement and residual current measurement. When Rogowski coil inputs are used, DIP switches SW2:1 and SW2:2 are used to select the type (A, B, or C type). The fault current pick-up levels are set by using the trimmers (see the image below). The threshold for phase overcurrent is typically set to 50 % above the highest load current. The residual overcurrent is typically set to be very sensitive. You can get an accurate setting by injecting the desired set current into the phase and residual current inputs of the device and by adjusting the trimmers until the phase and residual current indicator LEDs are lit. You can fine-tune the current threshold setting by adjusting the trimmers and switching between lit and unlit LEDs.

Figure. 8.1 - 14. Overcurrent setting trimmers.

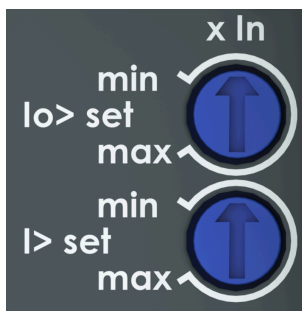

8.2 DIP switch settings

Configuration of the operation logic and other functionalities are done with DIP switches. The DIP switches are located at the back of the device.

Main operation logic can be defined with "Scheme selection" DIP switches. Logic schemes are described in the [Logic schemes](#) chapter.

Tripping can be set with DIP switches to require either just arc light ("Light only" mode) or both arc light and overcurrent simultaneously ("Light and current" mode). Adding overcurrent criteria ensures the device trips when an arc fault occurs but not when a strong natural light source hits the light sensor (e.g. sunlight). Device can detect overcurrent by measuring phase currents and residual current or by receiving overcurrent signal from external devices (mainly other AQ 100 series devices) which are connected to a binary input.

CBFP (circuit breaker failure protection) function can be enabled with "Fast / CBFP" DIP switch. CBFP time delay can be set with "100 ms / 150 ms" DIP switch. CBFP logic depends on the selected logic scheme. See the [Circuit breaker failure protection](#) chapter for more information.

If the device has been ordered with the optional Modbus module, the Modbus address is selected with DIP switches.

 **NOTICE!**
The T3 and T4 trip relays are always latching.

DIP switches in devices with CT inputs

Figure. 8.2 - 15. DIP switch diagram for AQ-110F with CT inputs.

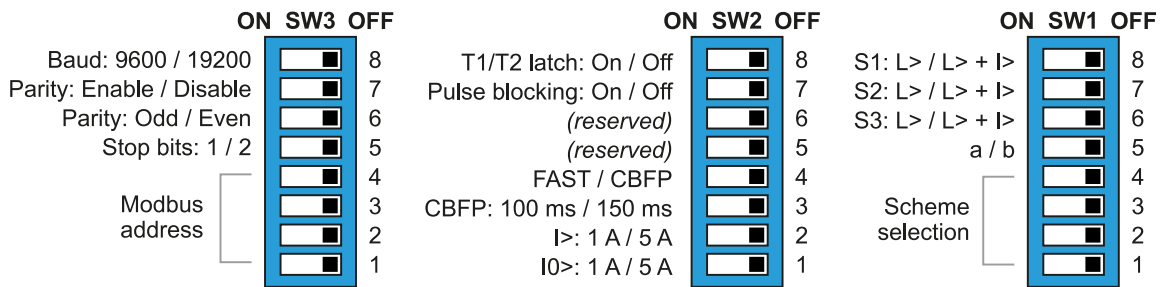

Table. 8.2 - 4. DIP switch settings for the SW1 group.

Switch	Function selection	ON (left position)	OFF (right position)
8	The tripping criterion for the S1 sensor channel.		
7	The tripping criterion for the S2 sensor channel.	Tripping on light only (L>).	Light detection only trips if overcurrent is also detected at the same time (L> + I>)
6	The tripping criterion for the S3 sensor channel.		
5	Selects the logic scheme. Please refer to the Logic schemes chapter.	Switch 1: 1	Switch 1: 0
4-1		Switch 2: 2	Switch 2: 0
		Switch 3: 4	Switch 3: 0
		Switch 4: 8	Switch 4: 0
		Switch 5: a	Switch 5: b

Table. 8.2 - 5. DIP switch settings for the SW2 group in devices with CT inputs.

Switch	Function selection	ON (left position)	OFF (right position)
8	Enables or disables trips latching.	Trips operate as latching relays.	Trip latching is disabled.
7	Enables or disables pulse blocking.	Pulse blocking in enabled.	Pulse blocking is disabled.
6	N/A	—	—
4	Enable or disable CBFP function. Depending on the selected scheme, some outputs activate after a time delay if the fault is not cleared on time. This DIP switch can be used to change the behavior of CBFP signals.	Depending on the selected scheme, CBFP signals are either disabled, unaffected or changed into instant signals.	CBFP signals are used.
3	The setting for the CBFP time.	The CBFP time is set to 100 ms.	The CBFP time is set to 150 ms.
2	The nominal current selection for the phase currents IL1, IL2 and IL3.	The nominal current is 1 A.	The nominal current is 5 A.
1	The nominal current selection for the residual current IO.	The nominal current is 1 A.	The nominal current is 5 A.

Table. 8.2 - 6. DIP switch settings for the SW3 group in devices with Modbus.

Switch	Function selection	ON (left position)	OFF (right position)
8	Selects the baud rate used by Modbus.	The baud rate is 9600.	The baud rate is 19200.
7	Selects whether the parity bit is enabled or not.	The parity bit is enabled.	The parity bit is disabled.
6	Selects whether the parity makes the string's total number odd or even.	The total number is odd.	The total number is even.
5	Selects the number of stop bits used to indicate the end of data transmission.	One (1) stop bit is used.	Two (2) stop bits are used.

Switch	Function selection	ON (left position)	OFF (right position)
4-1	Defines the Modbus address. The address always begins with 40. For example, when Pin 1 is in the left position (ON), the address is "41". When switch 4 is ON, the address is "48".	Switch 1: 1 Switch 2: 2 Switch 3: 4 Switch 4: 8	Switch 1: 0 Switch 2: 0 Switch 3: 0 Switch 4: 0

DIP switches in devices with Rogowski inputs

Figure. 8.2 - 16. DIP switch diagram for AQ-110F with Rogowski inputs.

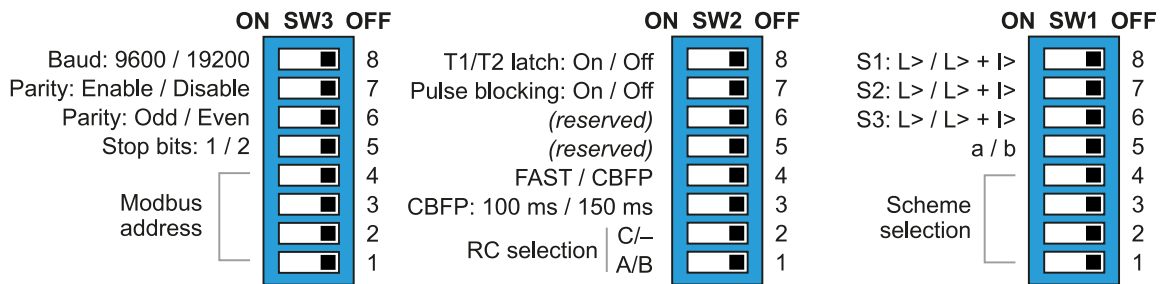

Table. 8.2 - 7. DIP switch settings for the SW1 group.

Switch	Function selection	ON (left position)	OFF (right position)
8	The tripping criterion for the S1 sensor channel.		
7	The tripping criterion for the S2 sensor channel.	Tripping on light only (L>).	Light detection only trips if overcurrent is also detected at the same time (L> + I>)
6	The tripping criterion for the S3 sensor channel.		
5	Selects the logic scheme. Please refer to the Logic schemes chapter.	Switch 1: 1	Switch 1: 0
4-1		Switch 2: 2 Switch 3: 4 Switch 4: 8 Switch 5: a	Switch 2: 0 Switch 3: 0 Switch 4: 0 Switch 5: b

Table. 8.2 - 8. DIP switch settings for the SW2 group in devices with Rogowski inputs.

Switch	Function selection	ON (left position)	OFF (right position)
8	Enables or disables T1 and T2 latching.	T1 and T2 operate as latching relays.	T1 and T2 latching is disabled.

Switch	Function selection	ON (left position)	OFF (right position)
7	Enables or disables high-speed output and binary output test pulses.	Test pulses are blocked.	Test pulses are in use.
6	N/A	—	—
5	N/A	—	—
4	Enable or disable CBFP function. Depending on the selected scheme, some outputs activate after a time delay if the fault is not cleared on time. This DIP switch can be used to change the behavior of CBFP signals.	Depending on the selected scheme, CBFP signals are either disabled, unaffected or changed into instant signals.	CBFP signals are used.
3	The setting for the CBFP time.	The CBFP time is set to 100 ms.	The CBFP time is set to 150 ms.
2	The RC selection for the Rogowski current inputs.	The RC selection is 333 mV/kA.	No RC selection.
1		The RC selection 22.5 mV/kA.	The RC selection is 100 mV/kA.

Table. 8.2 - 9. DIP switch settings for the SW3 group in devices with Modbus.

Switch	Function selection	ON (left position)	OFF (right position)
8	Selects the baud rate used by Modbus.	The baud rate is 9600.	The baud rate is 19200.
7	Selects whether the parity bit is enabled or not.	The parity bit is enabled.	The parity bit is disabled.
6	Selects whether the parity makes the string's total number odd or even.	The total number is odd.	The total number is even.
5	Selects the number of stop bits used to indicate the end of data transmission.	One (1) stop bit is used.	Two (2) stop bits are used.
4-1	Defines the Modbus address. The address always begins with 40. For example, when Pin 1 is in the left position (ON), the address is "41". When switch 4 is ON, the address is "48".	Switch 1: 1 Switch 2: 2 Switch 3: 4 Switch 4: 8	Switch 1: 0 Switch 2: 0 Switch 3: 0 Switch 4: 0



NOTICE!

The T3 and T4 trip relays are always latching. The BO1 binary output function is never latching.

8.3 Logic schemes

The schemes described below are the most commonly used ones for this device. However, additional schemes are also available; please contact your nearest Arcteq representative for more information on those schemes. The schemes are configured using the first DIP switch group (SW1) and its switches numbered 1...4 ("Scheme selection") and 5 ("a or b"). The scheme selection is based on binary arithmetic:

- Switch 1: 1
- Switch 2: 2
- Switch 3: 4
- Switch 4: 8
- Switch 5: a or b

Figure. 8.3 - 17. DIP switches used for selecting the logic scheme.

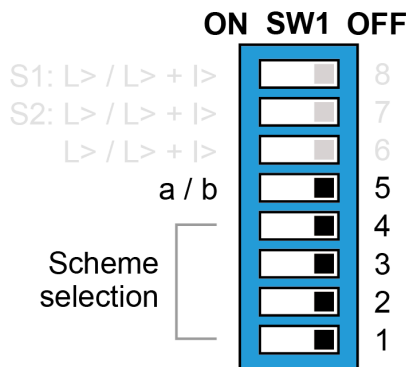

AQ 100 series arc protection devices can be used as a stand-alone device or as a part of a more complex arc protection system with multiple AQ 100 series devices. The most convenient way to set the device to a more complex arc protection system is to use Standard Arc Schemes (SAS). For detailed instructions on each of the available Standard Arc Schemes please refer to the AQ-SAS™ booklet (can be found at arcteq.com/downloads).

8.3.1 SS:0a Selective arc protection

The logic scheme SS:0a is designed for selective incoming feeder arc protection. It can be used for substations with one or more incoming feeders. This logic scheme is a modified version of SS:2a. The modifications are as follows:

- S1 channel can activate the arc quenching device control (AQD) signal
- AQD can be activated with external overcurrent signal (BI1) in addition to overcurrent signal ($I >$)
- Trip relay T2 CBFP signals follow "FAST / CBFP" DIP switch status

Figure. 8.3.1 - 18. SS:0a example application.

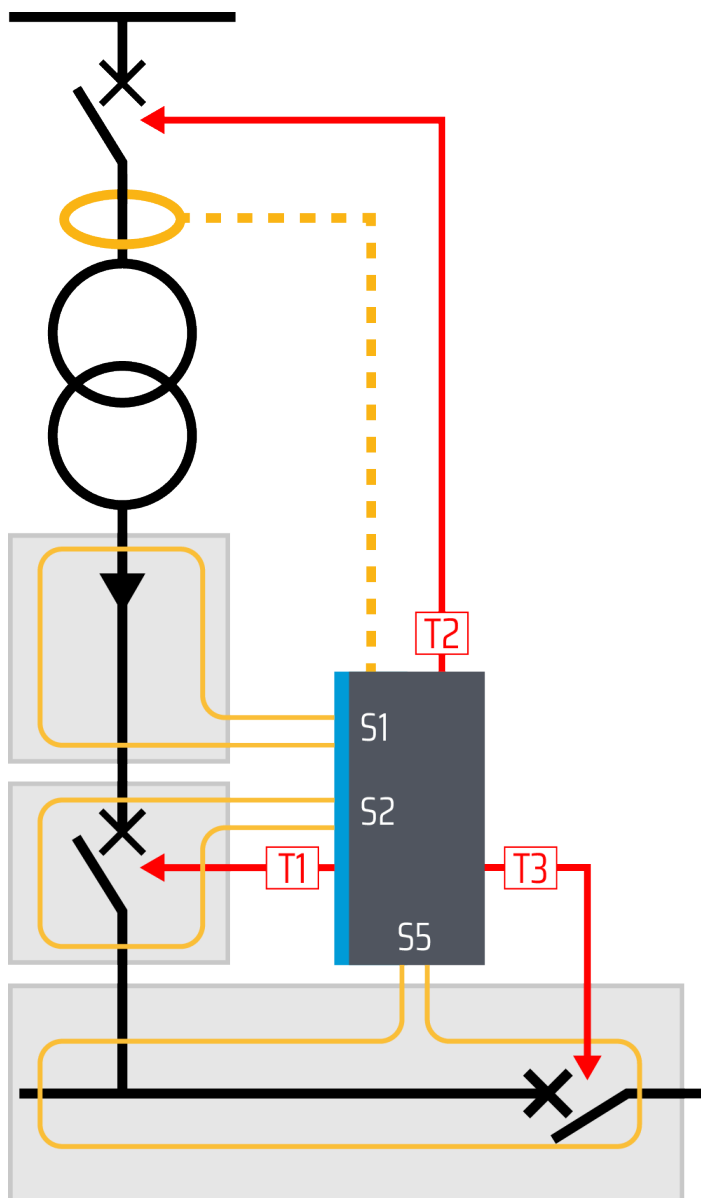

If a fault is detected in the incoming feeder cable compartment (S1), the circuit breakers on both sides of the transformer will be tripped with T1 and T2. If the fault is not cleared on time, T3 will trip the tie breaker (if applicable) and HSO2 sends a master trip signal to the outgoing feeder protection devices after the CBFP time delay has passed.

If a fault is detected in the incoming feeder's circuit breaker compartment (S2), the circuit breakers on both sides of the transformer (T1 and T2), the tie breaker (T3) as well as all outgoing feeders (HSO2) will be tripped. If a fault is detected in the busbar compartment (S3) or in the tie breaker compartment (S4), both the incoming feeder (T1) and the tie breaker (T3) as well as all outgoing feeders (HSO2) will be tripped. If the fault is not cleared on time, T2 will trip the incoming feeder's HV side circuit breaker after the CBFP time delay has passed.

The overcurrent signal is sent with the HSO1 signal to the outgoing feeder devices. BO1 can be used for sending overcurrent signal to other incoming feeder devices. BI1 can be used for receiving overcurrent signals from other incoming feeder devices.

Figure. 8.3.1 - 19. Logic matrix of SS:0a.

SS:0a		OUTPUTS								
		T1	T2	T3	T4	HSO1	HSO2	BO1	BO1 Pulse	AQD
INPUTS	S1	x ¹	x ¹	CBFP ¹	x ¹		CBFP ¹			x ²
	S2	x ¹	x ¹	x ¹	x ¹		x ¹		CBFP ³	x ²
	S3	x ¹	CBFP ¹	x ¹	x ¹		x ¹		CBFP ³	x ²
	Lext> (BI1 pulse)	x ¹	CBFP ¹	x ¹	x ¹		x ¹		CBFP ³	x ²
	Lext> (BI2)	x ¹	CBFP ¹	x ¹	x ¹		x ¹		CBFP ³	x ²
	Iext> (BI1)					x				
	I> (phase currents)					x		x		
	Io> (residual current)					x		x		

1. Activates only if channel has been set to "Light only" mode or if any overcurrent signal (I>, Io> or BI1) is ON.
2. Activates only if phase overcurrent signal (I>) or external overcurrent signal (BI1) is ON.
3. Activates only if external overcurrent (BI1) is ON.



NOTICE!

HSO2 CBFP signal is not activated if "FAST / CBFP" DIP switch is set to "FAST" mode.

Figure. 8.3.1 - 20. Simplified logic diagram of SS:0a.

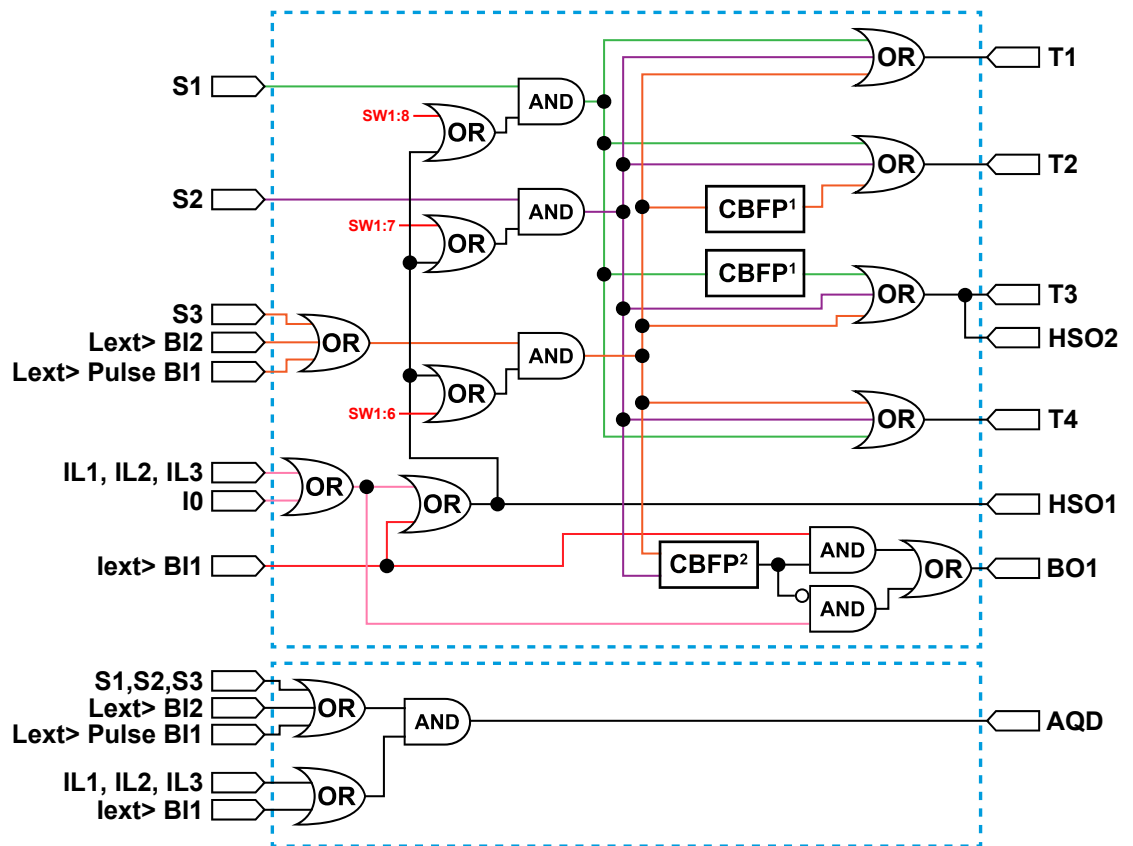

- 1) Signal is activated instantly if "Fast / CBFP" DIP switch is set to FAST mode.
- 2) Signal is NOT activated if "Fast / CBFP" DIP switch is set to FAST mode.

8.3.2 SS:1a Selective arc protection

The logic scheme SS:1a is designed for selective incoming feeder arc protection. It can be used for substations with one or more incoming feeders. This logic scheme is a modified version of SS:2a. The only difference is that arc quenching device control (AQD) activation allows any overcurrent signal ($I_{>}$, $I_{o>}$ or BI1).

Figure. 8.3.2 - 21. SS:1a example application.

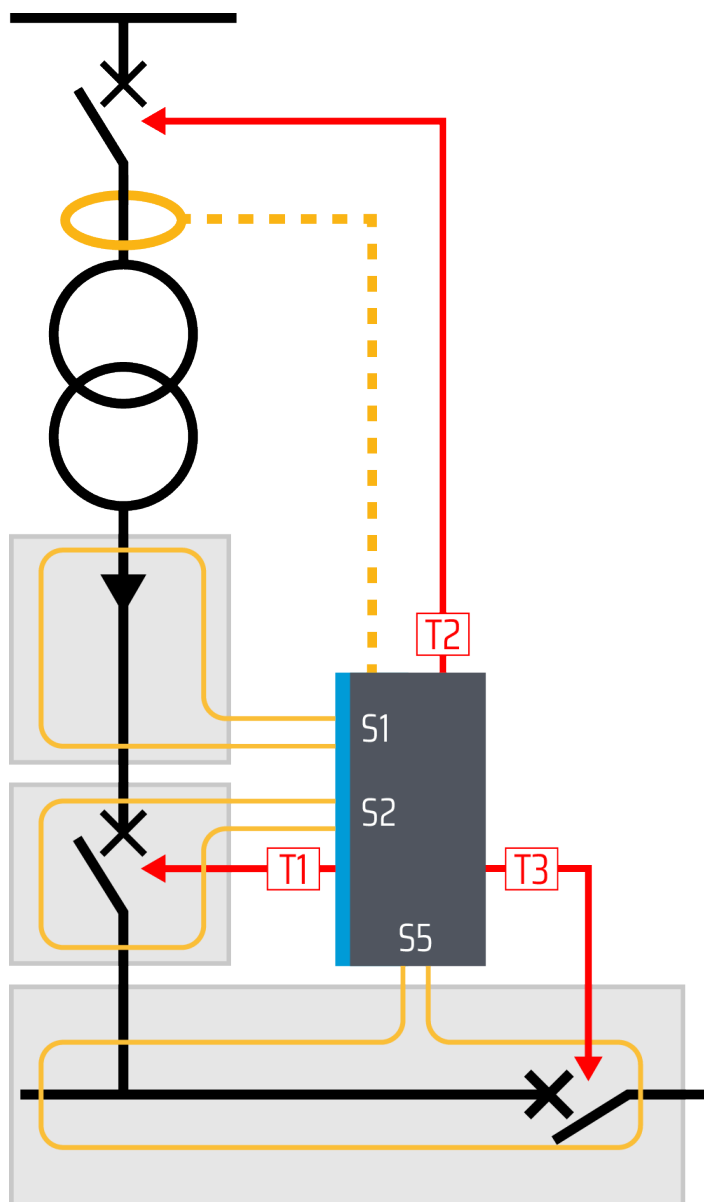

If a fault is detected in the incoming feeder cable compartment (S1), the circuit breakers on both sides of the transformer will be tripped with T1 and T2. If the fault is not cleared on time, T3 will trip the tie breaker (if applicable) and HSO2 sends a master trip signal to the outgoing feeder protection devices after the CBFP time delay has passed.

If a fault is detected in the incoming feeder's circuit breaker compartment (S2), the circuit breakers on both sides of the transformer (T1 and T2), the tie breaker (T3) as well as all outgoing feeders (HSO2) will be tripped. If a fault is detected in the busbar compartment (S3) or in the tie breaker compartment (S4), both the incoming feeder (T1) and the tie breaker (T3) as well as all outgoing feeders (HSO2) will be tripped. If the fault is not cleared on time, T2 will trip the incoming feeder's HV side circuit breaker after the CBFP time delay has passed.

The overcurrent signal is sent with the HSO1 signal to the outgoing feeder devices. BO1 can be used for sending overcurrent signal to other incoming feeder devices. BI1 can be used for receiving overcurrent signals from other incoming feeder devices.

Figure. 8.3.2 - 22. Logic matrix of SS:1a.

SS:1a		OUTPUTS								
		T1	T2	T3	T4	HSO1	HSO2	BO1	BO1 pulse ³	AQD
INPUTS	S1	x ¹	x ¹	CBFP ¹	x ¹		CBFP ¹		CBFP ⁴	
	S2	x ¹	x ¹	x ¹	x ¹		x ¹		CBFP	x ²
	S3	x ¹	CBFP ¹	x ¹	x ¹		x ¹		CBFP	x ²
	Lext> (BI1 pulse)	x ¹	CBFP ¹	x ¹	x ¹		x ¹		CBFP	x ²
	Lext> (BI2)	x ¹	CBFP ¹	x ¹	x ¹		x ¹		CBFP	x ²
	lxt> (BI1)					x				
	l> (phase currents)					x		x		
	lo> (residual current)					x		x		

1. Activates only if channel has been set to light only mode or if any overcurrent signal (l>, lo> or BI1) is ON.
2. Activates only if any of the overcurrent signals (l>, lo> or BI1) are ON.
3. Activates only if external overcurrent signal (BI1) is ON.
4. Delay time is 200 ms if "100 / 150ms" is set to "100ms". Delay time is 300 ms if "100 / 150ms" is set to "150ms".



NOTICE!

T2 uses CBFP regardless of "Fast / CBFP" DIP switch status.



NOTICE!

T3, HSO2 and BO1 pulse CBFP signals are NOT activated if "Fast / CBFP" DIP switch is set to "FAST" mode.

8.3.3 SS:1b Selective arc protection

The logic scheme SS:1b is designed for selective incoming feeder arc protection. It can be used for substations with one or more incoming feeders. This logic scheme is a modified version of SS:1a. In SS:1b the high-speed output HSO1 acts as an additional alarm contact or a master trip signal.

Figure. 8.3.3 - 24. SS:1b example application.

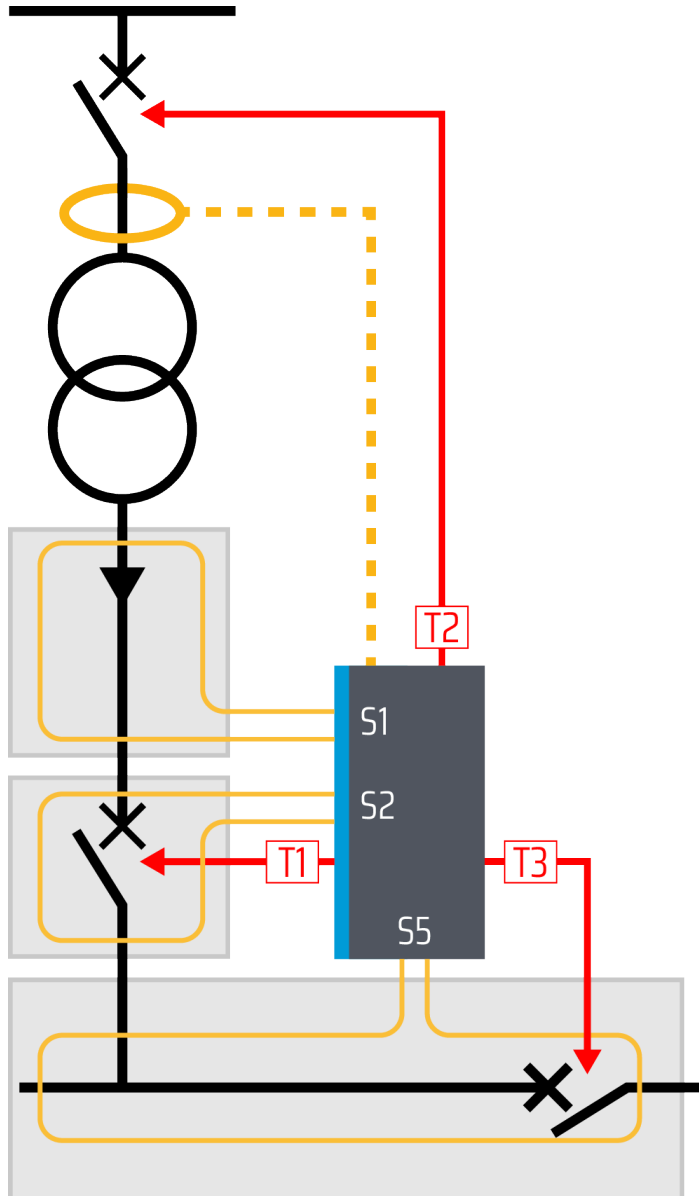

If a fault is detected in the incoming feeder cable compartment (S1), the circuit breakers on both sides of the transformer will be tripped with T1 and T2. If the fault is not cleared on time, T3 will trip the tie breaker (if applicable) and HSO2 sends a master trip signal to the outgoing feeder protection devices after the CBFP time delay has passed.

If a fault is detected in the incoming feeder's circuit breaker compartment (S2), the circuit breakers on both sides of the transformer (T1 and T2), the tie breaker (T3) as well as all outgoing feeders (HSO2) will be tripped. If a fault is detected in the busbar compartment (S3) or in the tie breaker compartment (S4), both the incoming feeder (T1) and the tie breaker (T3) as well as all outgoing feeders (HSO2) will be tripped. If the fault is not cleared on time, T2 will trip the incoming feeder's HV side circuit breaker after the CBFP time delay has passed.

BI1 can be used for receiving overcurrent signals from other incoming feeder devices. HSO1 can be used as an alarm signal.

Figure. 8.3.3 - 25. Logic matrix of SS:1b.

SS:1b		OUTPUTS								
		T1	T2	T3	T4	HSO1	HSO2	BO1	BO1 pulse ³	AQD
INPUTS	S1	x ¹	x ¹	CBFP ¹	x ¹	x ¹	CBFP ¹		CBFP ⁴	
	S2	x ¹	x ¹	x ¹	x ¹	x ¹	x ¹		CBFP	x ²
	S3	x ¹	CBFP ¹	x ¹	x ¹	x ¹	x ¹		CBFP	x ²
	Lext> (BI1 pulse)	x ¹	CBFP ¹	x ¹	x ¹	x ¹	x ¹		CBFP	x ²
	Lext> (BI2)	x ¹	CBFP ¹	x ¹	x ¹	x ¹	x ¹		CBFP	x ²
	lxt> (BI1)									
	l> (phase currents)							x		
	lo> (residual current)							x		

1. Activates only if channel has been set to light only mode or if any overcurrent signal (l>, lo> or BI1) is ON.
2. Activates only if any of the overcurrent signals (l>, lo> or BI1) are ON.
3. Activates only if external overcurrent signal (BI1) is ON.
4. Delay time is 200 ms if "100 / 150ms" is set to "100ms". Delay time is 300 ms if "100 / 150ms" is set to "150ms".



NOTICE!

T2 uses CBFP regardless of "Fast / CBFP" DIP switch status.



NOTICE!

T3, HSO2 and BO1 pulse CBFP signals are NOT activated if "Fast / CBFP" DIP switch is set to "FAST" mode.

Figure. 8.3.3 - 26. Simplified logic diagram of SS:1b.

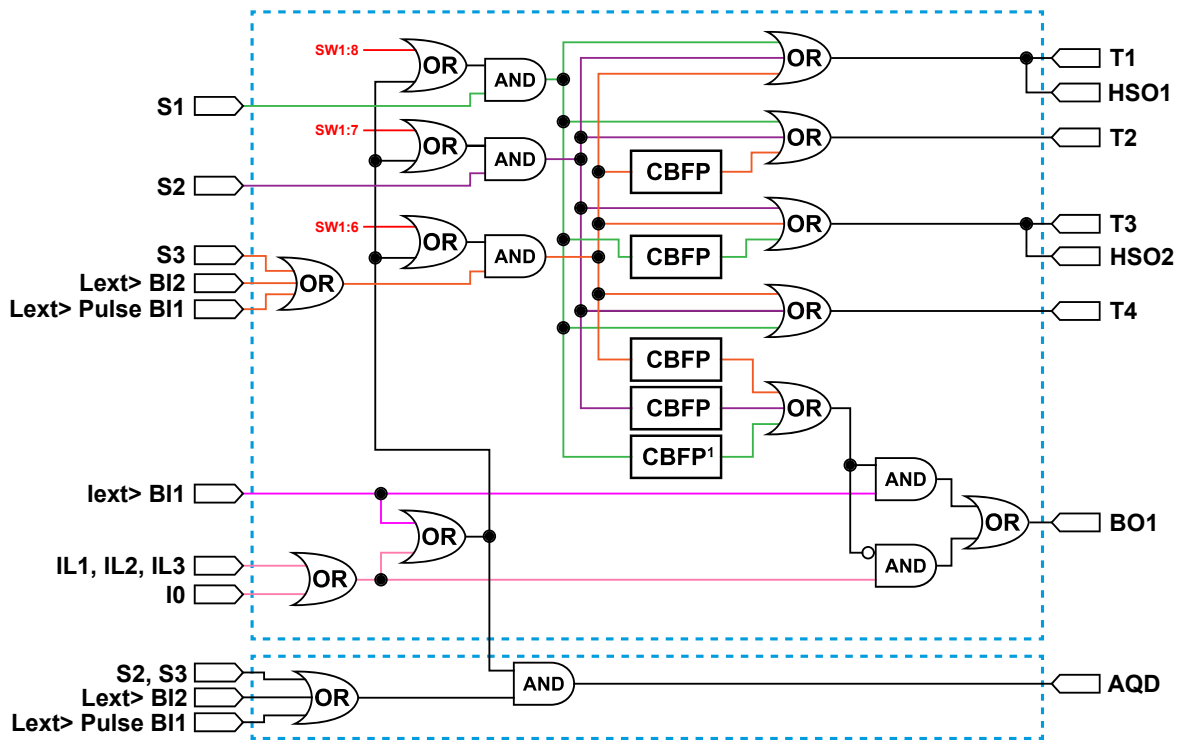

1) "100 / 150 ms" DIP switch can be used for choosing 200 ms or 300 ms time delay.

8.3.4 SS:2a Selective arc protection (recommended)

The logic scheme SS:2a is designed for selective incoming feeder arc protection. It can be used for substations with one or more incoming feeders.

Figure. 8.3.4 - 27. SS:2a example application.

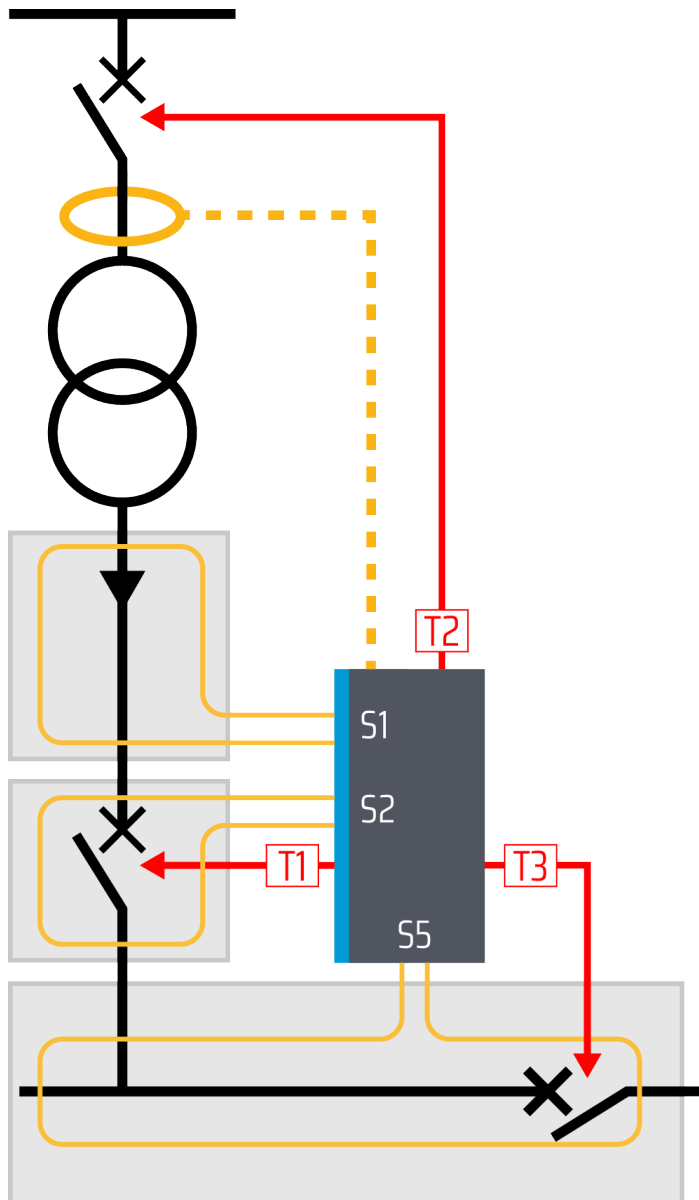

If a fault is detected in the incoming feeder cable compartment (S1), the circuit breakers on both sides of the transformer will be tripped with T1 and T2. If the fault is not cleared on time, T3 will trip the tie breaker (if applicable) and HSO2 sends a master trip signal to the outgoing feeder protection devices after the CBFP time delay has passed.

If a fault is detected in the incoming feeder's circuit breaker compartment (S2), the circuit breakers on both sides of the transformer (T1 and T2), the tie breaker (T3) as well as all outgoing feeders (HSO2) will be tripped. If a fault is detected in the busbar compartment (S3) or in the tie breaker compartment (S4), both the incoming feeder (T1) and the tie breaker (T3) as well as all outgoing feeders (HSO2) will be tripped. If the fault is not cleared on time, T2 will trip the incoming feeder's HV side circuit breaker after the CBFP time delay has passed.

The overcurrent signal is sent with the HSO1 signal to the outgoing feeder devices. BO1 can be used for sending overcurrent signal to other incoming feeder devices. BI1 can be used for receiving overcurrent signals from other incoming feeder devices.

You can find a more detailed description of this scheme in the AQ-SAS™ booklet.

Figure. 8.3.4 - 28. Logic matrix of SS:2a.

SS:2a		OUTPUTS								
		T1	T2	T3	T4	HSO1	HSO2	BO1	BO1 pulse ³	AQD
INPUTS	S1	x ¹	x ¹	CBFP ¹	x ¹		CBFP ¹		CBFP ⁴	
	S2	x ¹	x ¹	x ¹	x ¹		x ¹		CBFP	x ²
	S3	x ¹	CBFP ¹	x ¹	x ¹		x ¹		CBFP	x ²
	Lext> (BI1 pulse)	x ¹	CBFP ¹	x ¹	x ¹		x ¹		CBFP	x ²
	Lext> (BI2)	x ¹	CBFP ¹	x ¹	x ¹		x ¹		CBFP	x ²
	Iext> (BI1)					x				
	I> (phase currents)					x		x		
	Io> (residual current)					x		x		

1. Activates only if channel has been set to light only mode or if any overcurrent signal (I>, Io> or BI1) is ON.
2. Activates only if phase overcurrent signal (I>) is ON.
3. Activates only if external overcurrent signal (BI1) is ON.
4. Delay time is 200 ms if "100 / 150ms" is set to "100ms". Delay time is 300 ms if "100 / 150ms" is set to "150ms".



NOTICE!

T2 uses CBFP regardless of "Fast / CBFP" DIP switch status.



NOTICE!

T3, HSO2 and BO1 pulse CBFP signals are NOT activated if "Fast / CBFP" DIP switch is set to "FAST" mode.

Figure. 8.3.4 - 29. Simplified logic diagram of SS:2a.

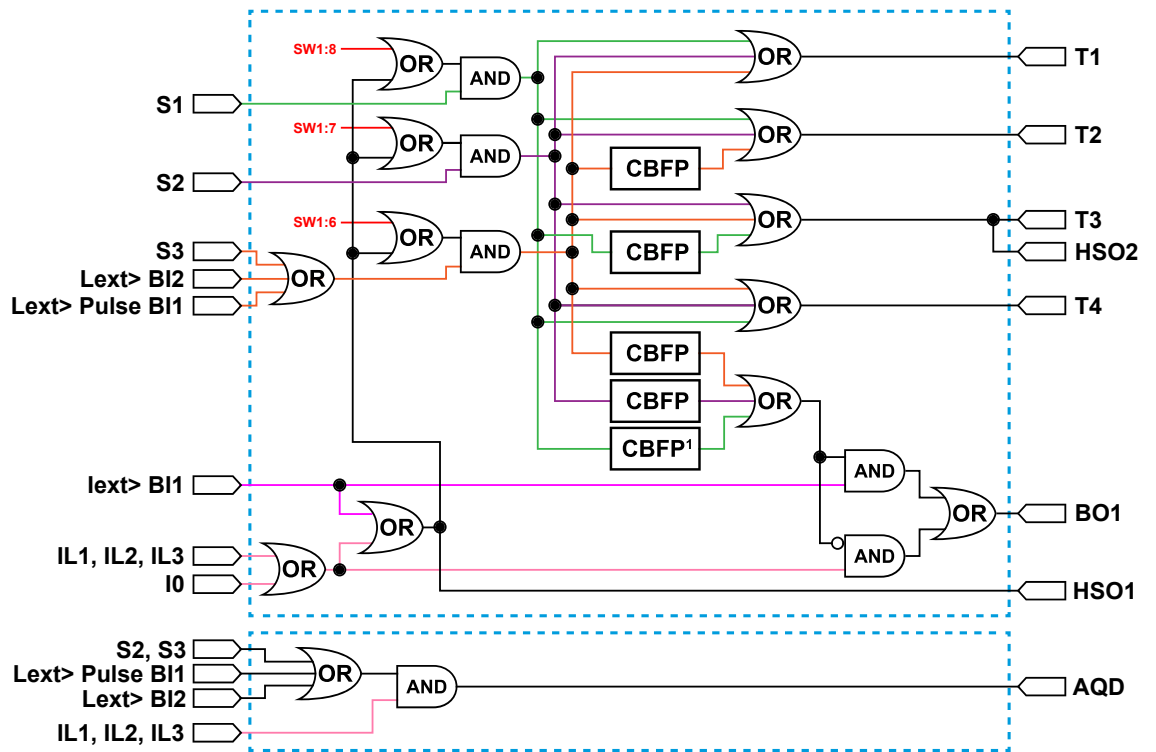

1) "100 / 150 ms" DIP switch can be used for choosing 200 ms or 300 ms time delay.

8.3.5 SS:2b Selective arc protection

The logic scheme SS:2b is designed for selective incoming feeder arc protection. It can be used for substations with one or more incoming feeders. The logic scheme SS:2b is a modification of SS:2a. In SS:2b the high-speed output HSO1 acts as an additional alarm contact or a master trip signal.

Figure. 8.3.5 - 30. SS:2b example application.

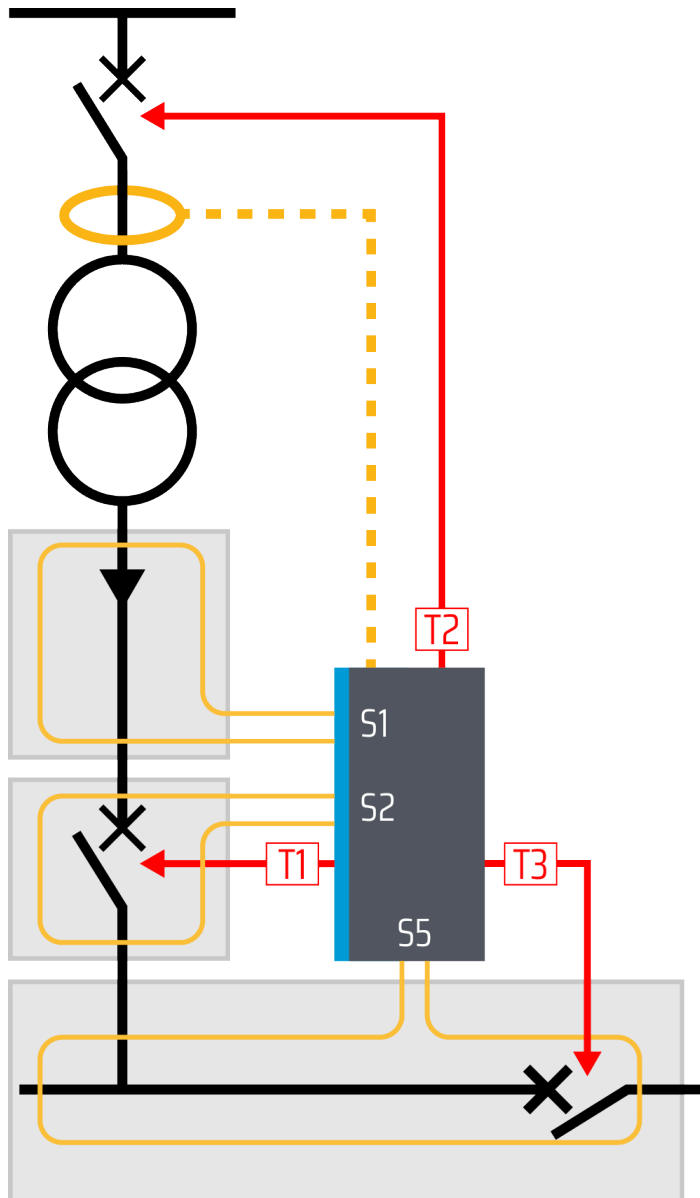

If a fault is detected in the incoming feeder cable compartment (S1), the circuit breakers on both sides of the transformer will be tripped with T1 and T2. If the fault is not cleared on time, T3 will trip the tie breaker (if applicable) and HSO2 sends a master trip signal to the outgoing feeder protection devices after the CBFP time delay has passed.

If a fault is detected in the incoming feeder's circuit breaker compartment (S2), the circuit breakers on both sides of the transformer (T1 and T2), the tie breaker (T3) as well as all outgoing feeders (HSO2) will be tripped. If a fault is detected in the busbar compartment (S3) or in the tie breaker compartment (S4), both the incoming feeder (T1) and the tie breaker (T3) as well as all outgoing feeders (HSO2) will be tripped. If the fault is not cleared on time, T2 will trip the incoming feeder's HV side circuit breaker after the CBFP time delay has passed.

BO1 can be used for sending overcurrent signal to other incoming feeder devices. BI1 can be used for receiving overcurrent signals from other incoming feeder devices.

Figure. 8.3.5 - 31. Logic matrix of SS:2b.

SS:2b		OUTPUTS								
		T1	T2	T3	T4	HSO1	HSO2	BO1	BO1 pulse ³	AQD
INPUTS	S1	x ¹	x ¹	CBFP ¹	x ¹	x ¹	CBFP ¹		CBFP ⁴	
	S2	x ¹	x ¹	x ¹	x ¹	x ¹	x ¹		CBFP	x ²
	S3	x ¹	CBFP ¹	x ¹	x ¹	x ¹	x ¹		CBFP	x ²
	Lext> (BI1 pulse)	x ¹	CBFP ¹	x ¹	x ¹	x ¹	x ¹		CBFP	x ²
	Lext> (BI2)	x ¹	CBFP ¹	x ¹	x ¹	x ¹	x ¹		CBFP	x ²
	Lext> (BI1)									
	I> (phase currents)							x		
	Io> (residual current)							x		

1. Activates only if channel has been set to light only mode or if any overcurrent signal (I>, Io> or BI1) is ON.
2. Activates only if phase overcurrent signal (I>) is ON.
3. Activates only if external overcurrent signal (BI1) is ON.
4. Delay time is 200 ms when "100 / 150 ms" DIP switch is set to "100 ms", 300 ms when it is set to "150 ms".



NOTICE!

T2 uses CBFP regardless of "Fast / CBFP" DIP switch status.



NOTICE!

T3, HSO2 and BO1 pulse CBFP signals are NOT activated if "Fast / CBFP" DIP switch is set to "FAST" mode.

Figure. 8.3.5 - 32. Simplified logic diagram of SS:2b.

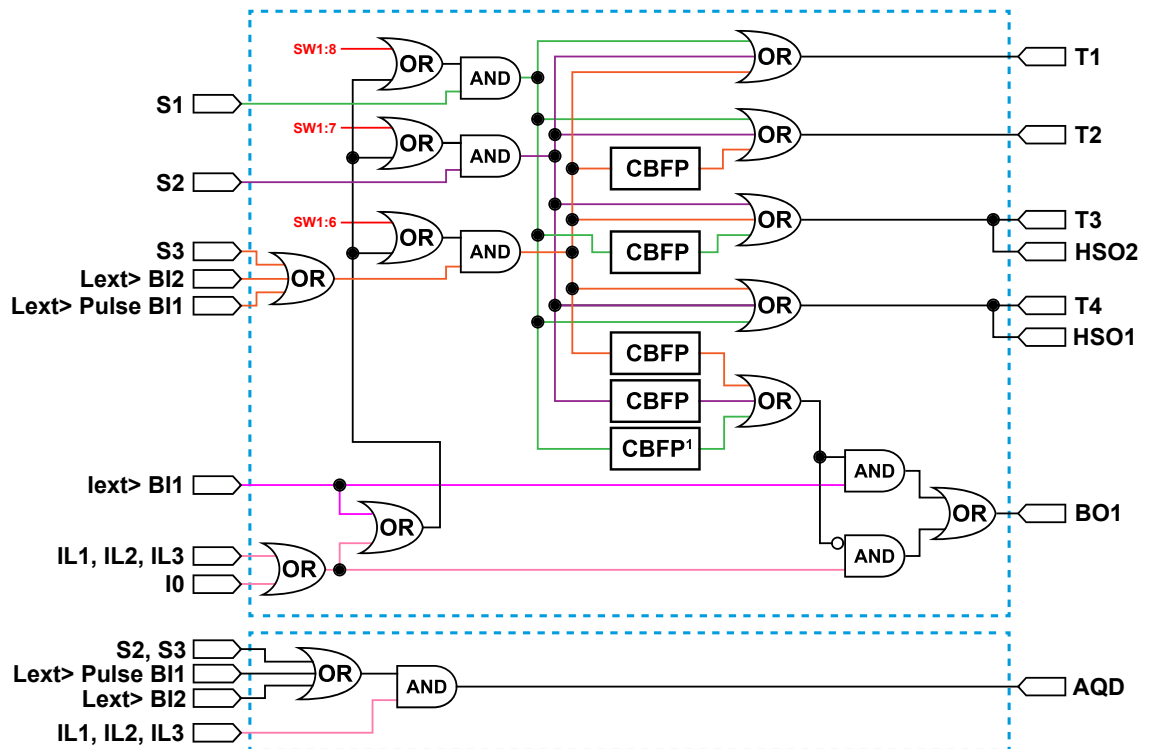

1) "100 / 150 ms" DIP switch can be used for choosing 200 ms or 300 ms time delay.

1. "100 / 150 ms" DIP switch can be used for choosing 200 ms or 300 ms time delay.

NOTICE!
CBFP signals are NOT activated if "FAST / CBFP" DIP switch is set to "FAST" mode.

8.4 Push button (SET)

The device has one push button, SET, and it can be used for all operational functions. The push button is used for:

1. Setting up the system (also known as auto-configuration)
2. Resetting the indicator LEDs
3. Resetting latched outputs
4. Checking the input connections

WARNING!
Do NOT use force when pushing the button, as this may cause the button to lodge deep inside the chassis!

Figure. 8.4 - 33. The "SET" push button on the device's front panel.

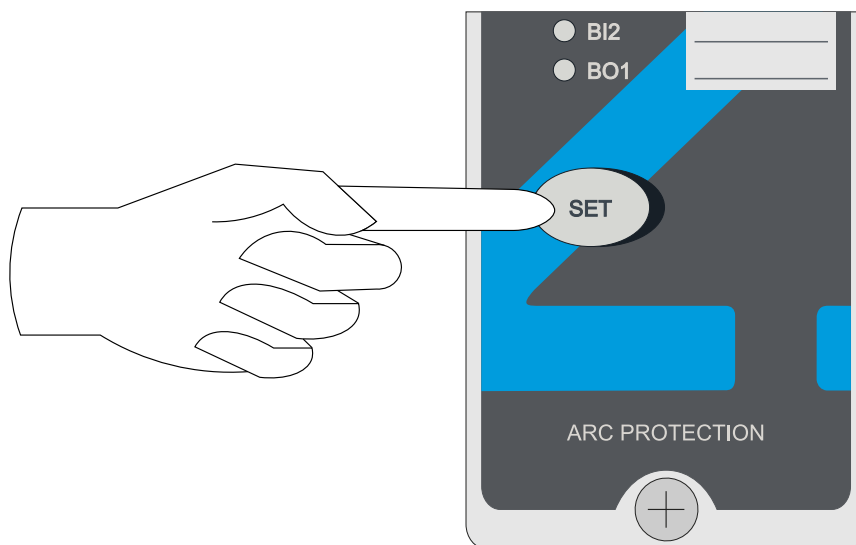

8.4.1 System setup (auto-configuration)

After DIP switches have been set to correct position and all sensors, binary inputs and binary outputs have been connected, a system setup procedure (also known as auto-configuration) must be performed. The sequence is initialized by pressing the **SET** push button for two seconds. This causes the sensor and binary I/O LEDs to start blinking. The device scans these inputs to see if they are connected; when an input is detected, the corresponding LED lights up to indicate that a connection was found. All inputs that are not connected continue to blink for three more seconds. Then, all LEDs are turned off. Additionally, the DIP switch settings are stored in the non-volatile memory after this sequence.

If the device detects any deviation from the saved configuration, self supervision system issues an alarm. See the [System self-supervision](#) chapter for more information.

All arc sensors are operational even when they have not been auto-configured. System setup is only used for self-supervision purposes.

NOTICE!



Please note that to reconfigure a device with fewer connections (BI or arc sensors) than in the previously memorized setup, one of the DIP switches must be moved back and forth once before the system setup procedure is carried out. You can reconfigure a device with more connections at any time without having to move one of the DIP switches.

8.4.2 Reset

All LED indications and latched trip relays can be reset by pressing the **SET** push button.

8.4.3 Input connection check

After the system setup (auto-configuration) procedure is completed, you can verify the connectivity of arc sensors and binary input channels by pressing the **SET** push button three (3) times within two (2) seconds. The LEDs of the corresponding arc sensors, binary input channels and the "Power" LED start blinking. The LEDs blink as many times as there are connected sensors and binary output channels from other devices.

8.5 Circuit breaker failure protection

The circuit breaker failure protection function is used for detecting a failure to open the circuit breaker when tripping command has been given by the arc protection relay. The CBFP function activates when the arc protection relay detects the presence of fault for a set duration (100 ms or 150 ms). In case of circuit breaker failure the arc protection relay will send a trip signal to the surrounding breakers. Please note that if the device is set to operate on both arc light and overcurrent, both conditions must persist to activate the CBFP command. The CBFP function can be set to operate either on a 100-ms or a 150-ms delay (please refer to the [DIP switch settings](#) chapter for more information). The operation logic of CBFP function depends on the chosen logic scheme (see the [Logic schemes](#) chapter for more information).

8.6 LED indicator functions

The AQ-110F device has nineteen (19) indication LEDs on the device's front panel. Apart from the "Power" and "Error" LEDs, the user can write their own identifications for each of the remaining LEDs on the text insert located in the transparent pocket next to the LEDs.

When the device is powered up, it performs an LED test. All LEDs turn on for two (2) seconds and then turn off; only the blue "Power" LED stays on.

When the device operates normally, only the blue "Power" LED is lit.

All current measuring channels (that is, IL1, IL2, IL3 and I0) have their own indication LEDs. When any channel measurement exceeds the set threshold value, its corresponding LED turns on. In an open CT condition both the corresponding current channel indicator LED and the "Error" LED are blinking.

If an arc sensor is activated, its corresponding LED turns on. Activated arc sensor LEDs will stay on until user has reset them with "SET" push button.

If there is a loose sensor wire or if the self-supervision function detects a configuration mismatch (that is, a new sensor has been attached but the auto-configuration system setup has not been run), the corresponding LED starts flashing and the "Error" LED activates.

The binary I/O LEDs indicate the status of the input and output lines. If any of the lines become active, the corresponding LED turns on. All light channel and trip indication LEDs are latched, even if the DIP switch settings are in the non-latched mode.

All LED indications are stored in the non-volatile memory (EPROM) to help identify the necessary trip information even after auxiliary power is lost. When the device is re-powered after a power supply loss, the front panel shows the status of all LEDs.

You can clear the LEDs by pushing the SET button.

8.7 LED operations guide

Table. 8.7 - 10. LED operation descriptions.

LED name (color)	Light off	Steady light	Blinking light	Action if abnormal
POWER (blue)	The auxiliary power supply is disconnected.	The auxiliary power supply is connected.	(N/A)	Check the power supply.

LED name (color)	Light off	Steady light	Blinking light	Action if abnormal
ERROR (red)	The system is healthy.	A system failure has occurred.	A configuration mismatch has been detected. Protection is partially operational.	Verify the system condition (see the System self-supervision and Troubleshooting chapters).
T1–T4 (red)	Normal status.	The trip relay has activated.	(N/A)	Check what caused the trip, clear the fault and reset the indicator LEDs with the push button.
S1–S3 (amber)	Normal status.	Light information has activated the sensor channel.	There is a sensor channel discontinuity or a system setup has not been performed.	Check the sensor continuity or perform a system setup (see the System setup chapter); or , check what activated the sensor.
AQD (amber)	Normal status.	AQD (arc quenching device) has been given a trip signal.	The fiber connection to the AQD (arc quenching device) has dropped off or a system setup has not been performed.	Check the fiber connection and/or the system configuration.
BI1–BI2 (amber)	Normal status.	The binary input has been activated.	The binary input has a loose connection.	Check the binary input wiring.
BO1 (amber)	Normal status.	The binary output has been activated.	(N/A)	—
IL1–IL3 (amber)	Normal status (the actual current is below the set threshold).	The measured current is above the set threshold.	There is an open CT connection in the channel.	Check the set current thresholds, or check the CT wiring.
I0 (amber)	Normal status (the actual current is below the set threshold).	The measured residual current is above the set threshold.	(N/A)	Check the threshold set for residual current.
HSO1–HSO2 (amber)	Normal status.	The high-speed output has been activated.	(N/A)	Check what activated the output, clear the fault and reset the indicator LEDs with the push button.

8.8 Modbus communication

This device can be ordered with Modbus RTU serial communication to report various signals to external devices. It is mainly designed for connecting to AQ 250 series devices but any Modbus master can be used. If the device has a Modbus connection to an AQ 250 series device, the AQ 250 series device can record events, display data on the display and report the events forward to SCADA system. Up to 16 devices with Modbus connection can be connected to one system. More information on connecting AQ 100 series devices to an AQ 250 series device can be found in AQ 250 series device manuals (arcteq.com/downloads).

For information on Modbus configuration, see the [DIP switches](#) chapter.

Using an AQ 250 series device as a master

The signals sent by the AQ 100 series device can be used for fault indications on the AQ 250 device and for reporting the signals forward with IEC 61850 or other communication protocol. Fault indication can be done by setting up an alarm display for each incoming signal or by building a mimic.

Figure. 8.8 - 34. An AQ 250 device can receive signals through Modbus and use them to control logic of the device, to create mimics, and to report the values to IEC 61850.

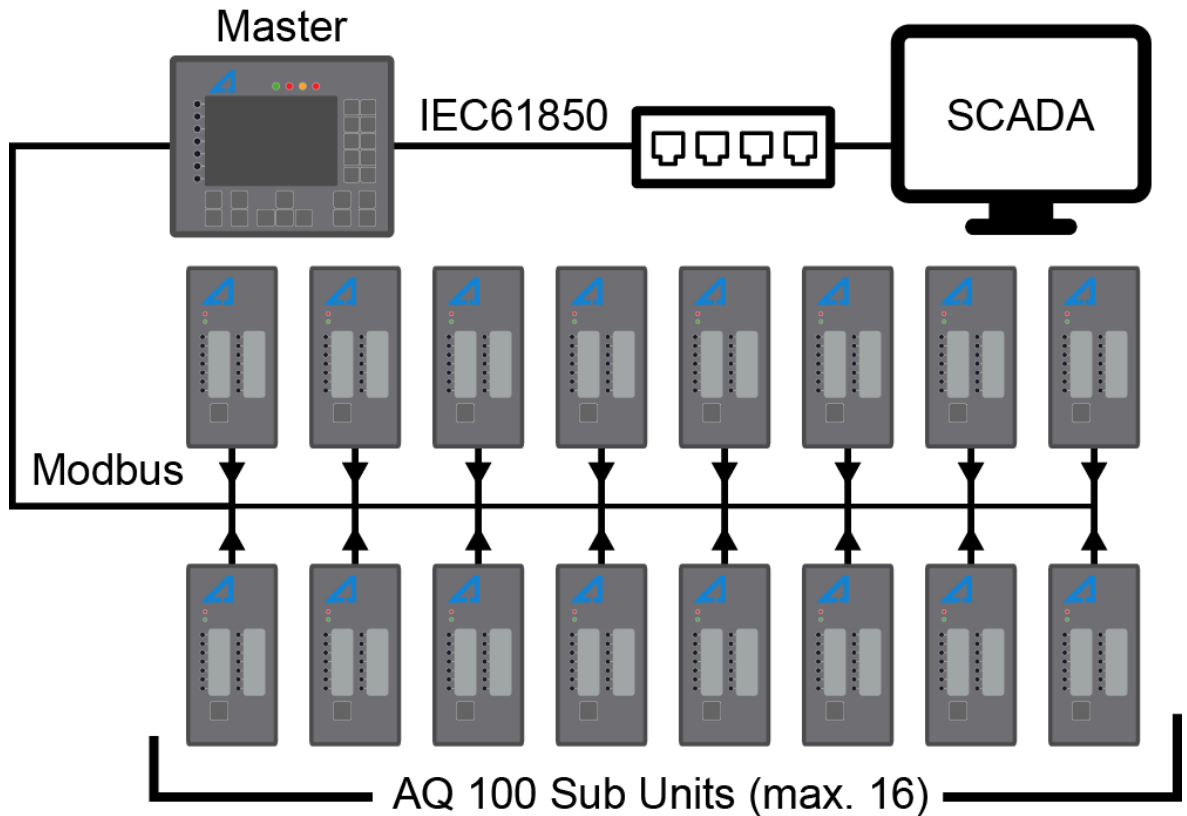

Figure. 8.8 - 35. Example mimic where sensor activation location is indicated with a symbol.

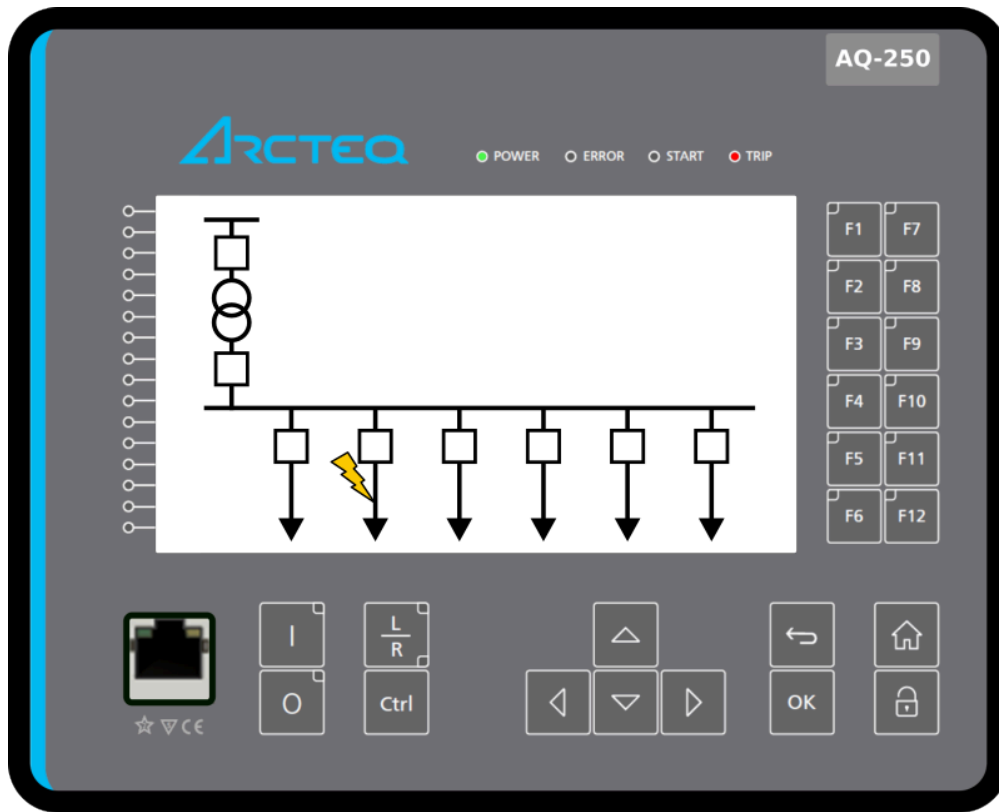

Figure. 8.8 - 36. In AQ-S254 it is possible to set up the display to show sensor activations in alarm display.



Modbus polling rate

The recommended maximum polling rate for the Modbus protocol is twice per second (2/s). The device also works with higher polling rates; however, unless there is a pressing reason to exceed the recommended rate, it is strongly advised to stay below the recommended maximum polling rate.

Modbus map

Available registers depend on the device type. All available Modbus signals are listed in the table below, but Modbus map with full details can be downloaded from Arcteq Relays website (arcteq.fi./downloads/).

Table. 8.8 - 11. Register descriptions.

Reg. No	Register Name	Description
1	Sensors installed to channel	Indicates if a sensor has been connected to the channel or not.
2	Sensor channel activations	Indicates sensor activation for each channel.
3	I/O activations	Indicates activation of I/O: <ul style="list-style-type: none"> • binary inputs • binary outputs • trip relays • high-speed outputs • arc quenching device control • phase overcurrent (I>) detection • earth fault detection
4	DIP switch settings	Position of the DIP switches (ON/OFF).
5-6	Serial number	Serial number of the device.
7	Latched sensor channel activations	Same as "Sensor channel activations", but the activated status is held until reset with "Clear latched signals" (reg. number 11).
8	Latched I/O activations	Same as "I/O activations", but the activated status is held until reset with "Clear latched signals" (reg. number 11).
9	Sensor channel errors	Activates if the number of sensors connected to the channel doesn't match with the loaded configuration (e.g. a sensor has been disconnected).
10	DIP switch settings, part 2	Position of the DIP switches (ON/OFF).
11	Clear latched signals (reg. numbers 7, 8 & 19)	Writeable register. Clears signals latched in registers 7, 8 & 19. These latched signals are not reset when "SET" button is pressed.
12	Device settings (DIP switch SW2)	Position of the DIP switches (ON/OFF).
13	Device settings (DIP switch SW3)	Position of the DIP switches (ON/OFF).
14	(reserved)	-
15	Number of sensors installed to the channel	Number of sensors connected to the channel (0...3).

16	Number of devices connected to the input (BI1 & BI2)	Detected number of devices (binary output or high-speed output) connected to the binary input.
17	Number of devices connected to the input (BI3 & BI4)	Detected number of devices (binary output or high-speed output) connected to the binary input.
18	Number of devices connected to the input (BI5 & BI6)	Detected number of devices (binary output or high-speed output) connected to the binary input.
19	I/O channels activated, extended (Latched)	Same as "I/O activations", but the activated status is held until reset with "Clear latched signals" (reg. number 11).
20	Measured current IL1 - ADC Raw values	Raw phase current value measured by IL1 channel.
21	Measured current IL2 - ADC Raw values	Raw phase current value measured by IL2 channel.
22	Measured current IL3 - ADC Raw values	Raw phase current value measured by IL3 channel.
23	I0: Measured current, ADC values	Raw residual current value measured by I0 channel.
24	IL1, IL2 & IL3: Set overcurrent level, ADC values	Raw phase overcurrent setting level in use.
25	I0: Set overcurrent level, ADC values	Raw earth fault setting level in use.
26	IL1: Measured current, calculated, A	Phase current value measured by IL1 channel in amperes.
27	IL2: Measured current, calculated, A	Phase current value measured by IL2 channel in amperes.
28	IL3: Measured current, calculated, A	Phase current value measured by IL3 channel in amperes.
29	I0: Measured current, calculated, A	Residual current value measured by I0 channel in amperes.
30	IL1, IL2 & IL3: Set overcurrent level, calculated, A	Phase overcurrent setting level in use in amperes.
31	I0: Set overcurrent level, calculated, A	Earth fault setting level in use in amperes.
32	Error types	Error types are listed in the table below.

Table. 8.8 - 12. Error types.

Code	Name	Description
PSCM	Point sensor connection monitoring	Activates if any point sensor channel is missing sensors or has too many sensors compared to installed number.

Code	Name	Description
FLCM	Fiber loop connection monitoring	Activates if any fiber loop channel is missing its loop or has the loop connected without installation.
BICM	Binary input connection monitoring	Activates if any binary input channel is missing its self-supervision pulses or has too many self-supervision pulses compared to the installed number.
DSSM	DIP switch setting monitoring	Activates if any DIP switch setting is changed, and thus, different than the settings installed.
DIVM	Device internal voltage monitoring	Activates if the monitored internal voltage drops below properly functioning level.
PSLM	Point sensor latch monitoring	Activates if any point sensor channel is steady on for too long.
FLLM	Fiber loop latch monitoring	Activates if any fiber loop channel is steady on for too long.
CTCM	Current transformer connection monitoring	Activates if any current input channel is at zero when at least one current channel is over $0.2 \times I_n$.

8.9 Non-volatile memory

All critical system data (such as DIP switch settings and the system setup file) are stored in the non-volatile memory (EPROM) to ensure accurate operation and full self-supervision even if auxiliary power is lost temporarily.

Additionally, all LED indications are stored in the non-volatile memory to provide a quick recovery of the system status indication. This feature is especially important if tripping causes the device to lose its auxiliary power.

The non-volatile memory does not require a power supply to maintain the information and it retains the settings and the indications permanently without power.

9 System self-supervision

AQ 100 series devices have an extensive self-supervision function, including both internal functions and external connections. The self-supervision function monitors the following:

- power supply
- hardware
- software
- binary input connection(s)
- sensor connection(s)
- DIP switch settings
- current transformer supervision

When the device's condition is healthy and is powered on, the "Power" LED is lit and the system failure (SF) relay is energized. If the self-supervision function detects a faulty condition or if the power supply fails, the SF relay is released and the "Error" LED becomes lit.

Fiber loop connection monitoring

Fiber loop channel(s) is monitored by a test light pulse that travels through the loop from TX (transmitter) connector to RX (receiver) connector. If a discontinuity is detected, the "Error" LED turns on, the SF relay releases, and the LED of the corresponding faulty sensor channel starts blinking. If the error is resolved, the device automatically clears the system failure status, energizing the SF relay and turning off the "Error" LED. The device remains in Error mode until the sensors are connected again.

Binary input connection monitoring

During system setup (auto-configuration) AQ 100 series device checks how many AQ 100 device binary outputs or high-speed outputs have been connected to binary inputs. Each AQ 100 series device binary output and high-speed output constantly sends a short pulse every second which the receiving binary input uses to count the number of connected devices. If any of the outputs are disconnected after the system setup, the binary input will detect the mismatch and the device will go into Error mode and the binary input LED will blink. If the error is resolved, the device automatically clears the system failure status, energizing the SF relay and turning off the "Error" LED.

DIP switch setting monitoring

The device goes into Error mode, if a DIP switch setting is changed after the system setup procedure has been performed. However, the configured (stored) settings are still valid and the device is still operational.

Current transformer supervision

In AQ 100 series devices with current measurements the self-supervision function also monitors the three phase current transformer circuit. If the current flow exceeds $0.2 \times I_n$ in any of the phases, the device assumes that the switchgear is energized and the function monitors the phases for an open connection. If at least one of the phases remains above $0.2 \times I_n$ while at least one of the others are at zero, the device issues an open CT alarm: the SF relay is released, the "Error" LED is turned on and the LED of the faulty phase(s) starts blinking.

10 Dimensions and installation

The device can be either door-mounted or panel-mounted in a standard 19 inch rack. The device's dimensions (without PCBs) are as follows:

- Height: 177 mm (6.97 in)
- Width: 102 mm (4.02 in)
- Depth: 168 mm (6.61 in).

The figure below presents the dimension of the device visually. It also shows the dimensions of the cut-out (bottom-left) required when mounting the device on a panel.

Figure. 10 - 37. Dimensions of the device.

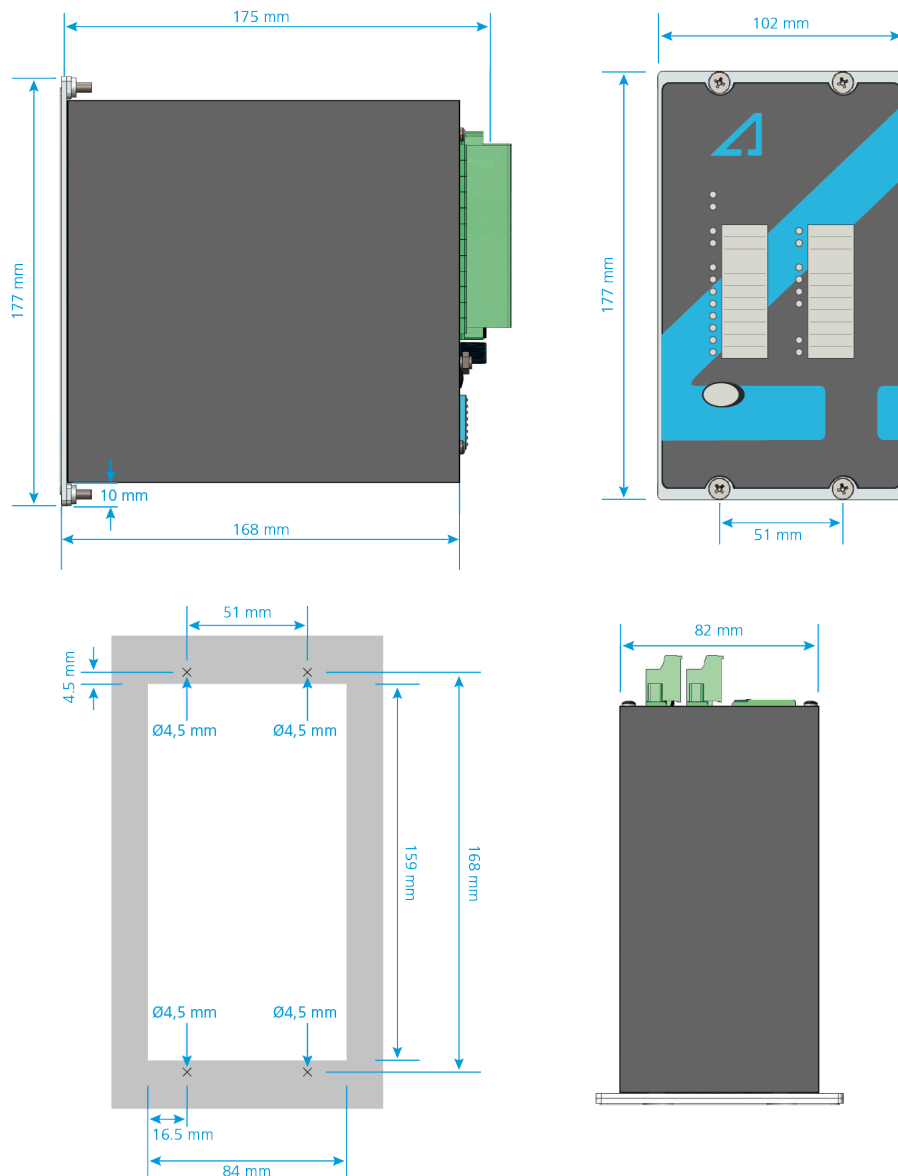
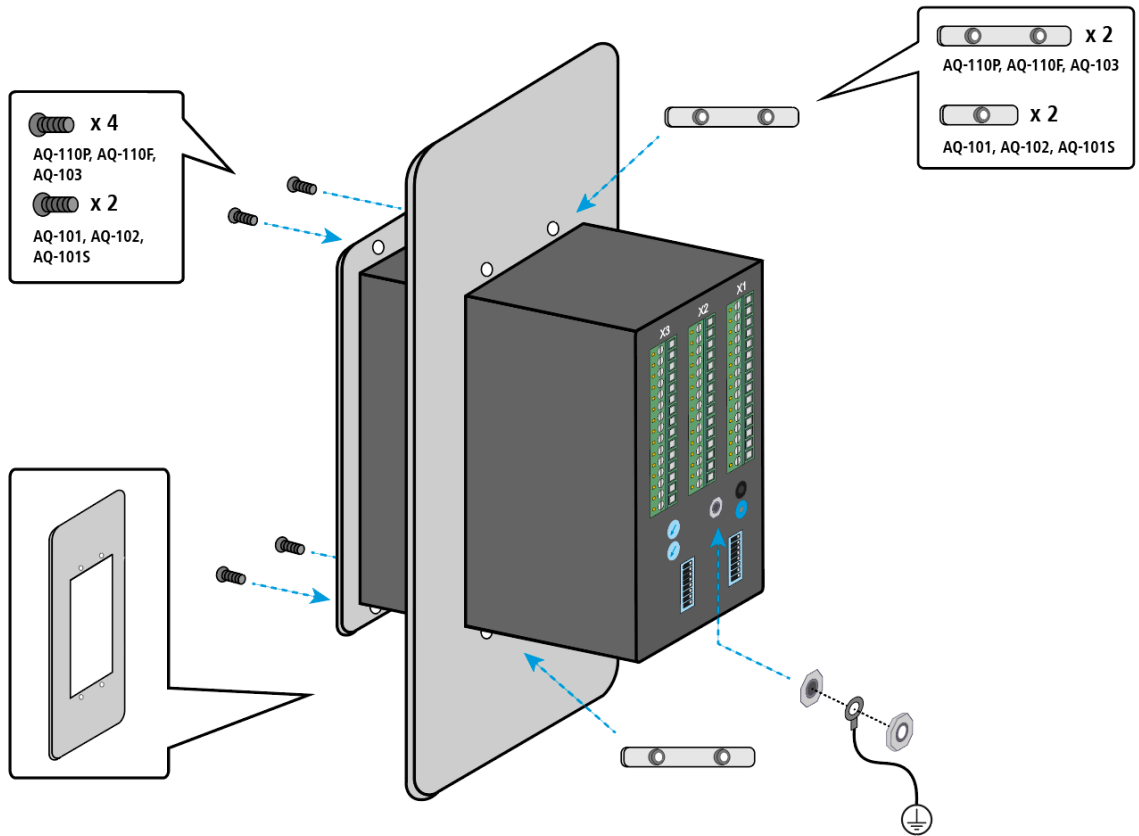
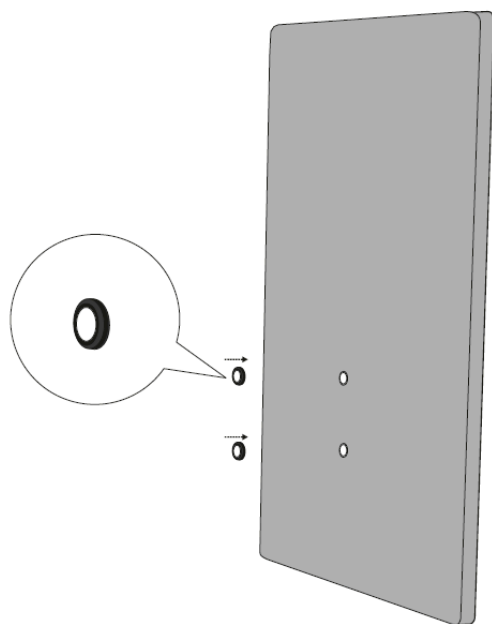

Figure. 10 - 38. Installing a AQ-100 series device to a door.



Fiber loops

1. Drill holes on the wall for the sensor cable to enter the protected compartment.
2. Install protective covers in the holes to ensure the sensor cable remains unharmed by rough edges.



3. Run the sensor cable through the holes and along the protected area. Fasten it to the compartment walls with cable clips or some other appropriate anchoring method.

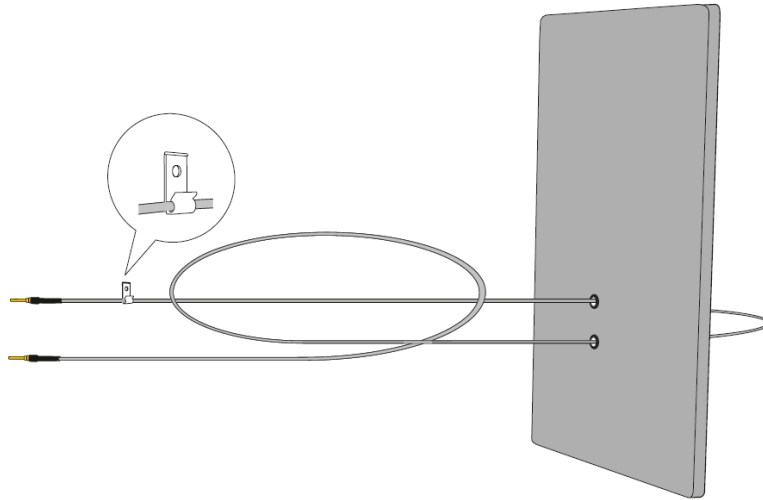

4. Turn the black and blue receiver ("Rx") and transceiver ("Tx") screws counter-clockwise and plug in the sensor cable terminals. Then turn the screws clockwise to secure the terminals in their place.

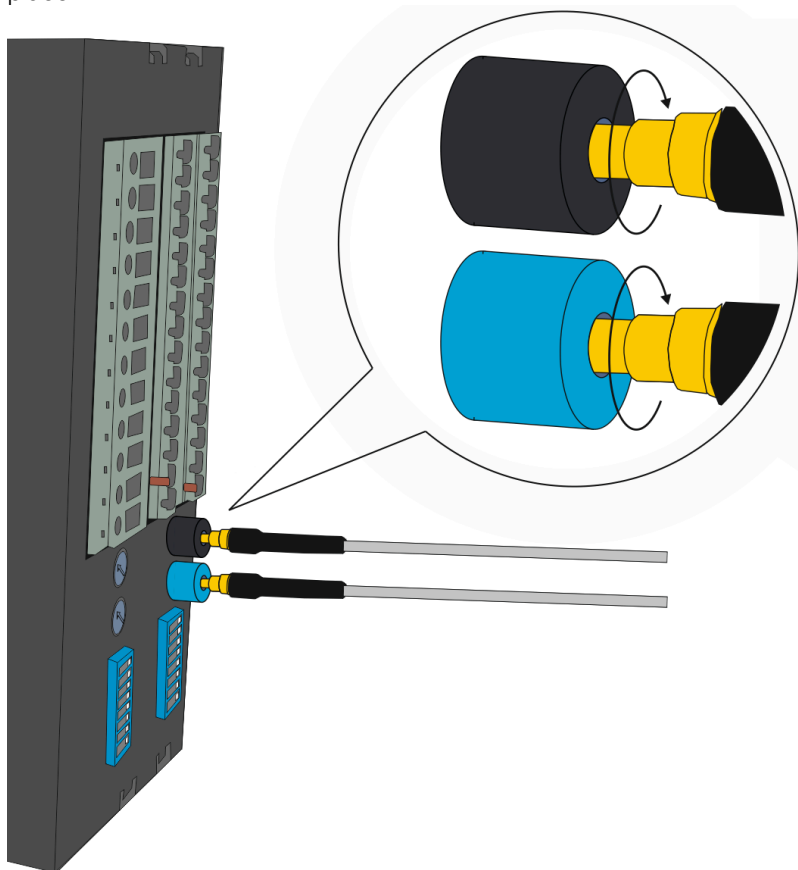

11 Testing

It is recommended that the device is tested prior to substation energizing. Testing is carried out by simulating an arc light for each sensor and verifying that the correct trip contact(s) tripped and that the correct indicator LED(s) turned on.

Any strong camera flash works well to simulate arc light. Please note that small LED lights like smartphone flashes are not strong enough to activate a point sensor or a fiber loop. Having a self-timer helps with the testing process because it can be connected to the test kit. Any strong flashlight works to test non-latched signals and the CBFP function. Before testing please check that the equipment used has a fully charged battery.

11.1 Testing the light-only mode

1. Check that the DIP switch settings are positioned according to your application.
2. Activate the camera flash within 30 cm (12 inches) of the sensor that is being tested.
3. Verify that the indicator LED of the corresponding sensor channel is lit.
4. Verify the activation(s) of the trip relay(s) by checking the circuit breaker's status, or by monitoring the trip contact's status. The circuit breaker should open, or the contacts operate. Please note that you achieve the best test results when you operate the circuit breaker while testing.
5. Verify that the indicator LED(s) of the corresponding trip relay(s) is lit.
6. If you are using the BO1 binary output and/or one or both of the high-speed outputs, verify their signal activation either through the status change of the relevant input, or by measuring the signal output voltage. Please note that BO1 is of the non-latched type.
7. If you are using the BO1 binary output and/or one or both of the high-speed outputs, also verify that their corresponding LED is lit.
8. Press the **SET** push button to reset all indications and latches.
9. If you are using the BI2 binary input as the master trip, activate it and verify that the trip has occurred by repeating the steps 4 and 5.
10. Press the **SET** push button to reset all indications and latches.
11. Repeat the steps 1 through 10 for all sensors.

11.2 Testing the light and current mode

1. Check that the DIP switch settings are positioned according to your application.
2. Activate the following two things simultaneously: the camera flash within 30 cm (12 inches) of the sensor that is being tested, and the binary input used for the overcurrent condition (I>).
3. Verify that the indicator LED of the corresponding sensor channel is lit.
4. Verify that the indicator LED of the binary input is lit.
5. Verify the activation(s) of the trip relay(s) by checking the circuit breaker's status, or by monitoring the trip contact's status. The circuit breaker should open, or the contacts operate. Please note that you achieve the best test results when you operate the circuit breaker while testing.
6. Verify that the indicator LED(s) of the corresponding trip relay(s) is lit.
7. If you are using the BO1 binary output or a high-speed output (HSO1 and/or HSO2), verify the signal activation either through the status change of the relevant input, or by measuring the signal output voltage.
8. If you are using the BO1 binary output or a high-speed output (HSO1 and/or HSO2), also verify that the corresponding LED is lit. Please note that BO1 is of the non-latched type.
9. Activate the camera flash within 30 cm (12 inches) of the sensor but do not activate the binary input used for the overcurrent condition (I>).
10. Verify that no trip has occurred and only the indicator LED of the sensor activation is lit.
11. If you are using the BO1 signal and have configured it to send light information, verify that it is activated.

12. Press the **SET** push button to reset all indications and latches.
13. If you are using a binary input as the master trip, activate it and verify that the trip has occurred by repeating the steps 5 and 6.
14. Press the **SET** push button to reset all indications and latches.
15. Repeat the steps 1 through 12 for all sensors.

11.3 Testing the CBFP function

The circuit breaker failure protection (CBFP) function is tested by taking the light signal and the additional trip criterion signal (if applicable) and leaving them active for longer than the set CBFP time (that is, 100 or 150 ms). Check that the correct outputs activated after the set delay time.

11.4 Testing the operation time

An operation time test is not required at commissioning as it is performed by the manufacturer both as a type test and as a routine production test. If you want to have more information of these tests, please refer to the routine test reports sent with the AQ-110 device and/or consult your nearest Arcteq representative for the type test reports.

However, if it is deemed necessary, you can conduct an on-site timing test with the following instructions.

1. Use a calibrated relay test set.
2. Connect one of the test set's outputs to a strong camera flash to initialize the flash and to configure the set's timer to start simultaneously with the flash.
3. Connect one of the AQ-110 device's trip outputs (T1, T2, T3, T4) or high-speed outputs (HSO1, HSO2) to a test set input and configure the input to stop the timer.
4. Place the camera flash within 30 cm (12 inches) of the sensor.
5. Initiate the flash and the timer by using the test set output.
6. Read the measured time between the simulated arc light and the operation of the trip contact.
7. Subtract the digital input delay of the test set from the final measured time (if applicable). For specific test instructions, please consult the manufacturer of the relay test set.

11.5 Test plan example



NOTICE!

Please note that the following test plan is designed for devices with CT inputs!



Basic data	
Date:	
Substation:	
Switchgear:	
Serial number:	

Preconditions	Additional notes
Trip mode (channel 1):	<input type="checkbox"/> L> <input type="checkbox"/> L> + I>
Trip mode (channels 2, 3, 4):	<input type="checkbox"/> L> <input type="checkbox"/> L> + I>
BI master trip in use:	<input type="checkbox"/> Yes <input type="checkbox"/> No
CBFP in use:	<input type="checkbox"/> Yes <input type="checkbox"/> No
CBFP time setting:	<input type="checkbox"/> 100 ms <input type="checkbox"/> 150 ms

Object activated	LED active	T1, T2, T3, T4 active	BO1 active	Additional notes
Sensor channel 1	S1			
	S2			
	S3			
Sensor channel 2	S1			
	S2			
	S3			
Sensor channel 3	S1			
	S2			
	S3			
Sensor channel 4	S1			
	S2			
	S3			
Fiber sensor channel				
Binary inputs	BI1			
	BI2			
Phase current (IL1, IL2, IL3)				
Residual current (IO)				

Involved personnel	
Tested by:	
Approved by:	

12 Troubleshooting

Table. 12 - 13. Troubleshooting guide for AQ-110x variants.

Problem	Possible solution(s)
The sensor does not activate during testing.	Check the sensor's cable wiring. <u>or</u> Check the testing equipment, especially the camera flash intensity (see the Testing chapter for more information).
The trip relay does not operate even when the sensor is activated.	Tripping might require overcurrent signal simultaneously with light signal. Check the DIP switch settings (see the DIP switch settings chapter for more information).
The current measurement's indicator LED is continuously lit.	Check the set current threshold (see the Current threshold settings chapter for more information).
The current measurement's indicator LED is blinking.	Check that the connections of the three phase currents are correct (see the System self-supervision for more information).

13 Technical data

13.1 Mounting and installation

Table. 13.1 - 14. Technical data for relay mounting and installation.

Panel: - material - thickness (min...max)	metal 1.0...5.0 mm (0.04...0.20 in)
Panel mounting: - screw type - key size - tightening torque (min...max)	ISO 14581 M4x12, galvanized Torx T20 1.5...2.0 N·m (13.3...17.7 lbf·in)
Grounding: - nut type - key size - tightening torque (min...max)	DIN934-M5 galvanized 8 2.5...3.0 N·m (22.1...26.6 lbf·in)
Connector X1: - connector type - wire cross section (min...max) - minimum stripping length - screw tightening torque (min...max)	Phoenix Contact FRONT-MSTB 2,5/4-GF-5,08 0.34...2.5 mm ² (24...12 AWG) 10 mm (0.39 in) 0.5...0.6 N·m (4.4...5.3 lbf·in)
Connector X2: - connector type - wire cross section (min...max) - minimum stripping length - screw tightening torque (min...max)	Phoenix Contact FRONT-MSTB 2,5/15-STF-5,08 0.34...2.5 mm ² (24...12 AWG) 10 mm (0.39 in) 0.5...0.6 N·m (4.4...5.3 lbf·in)
Connector X3 (when the device has standard CT inputs): - connector type: - wire cross section (min...max) - minimum stripping length - screw tightening torque (min...max)	Phoenix Contact FRONT 4-H-6,35-12 0.5...6.0 mm ² (20...9 AWG) 14 mm (0.55 in) 0.5...0.6 N·m (4.4...5.3 lbf·in)
Connector X3 (when the device has Rogowski inputs): - connector type - wire cross section (min...max) - minimum stripping length - screw tightening torque (min...max)	Phoenix Contact FRONT 2,5/H/SA 5/4 0.2...2.5 mm ² (24...13 AWG) 9 mm (0.35 in) 0.4...0.5 Nm (3.5...4.4 lbf·in)
Connector X4 (when the device has Rogowski inputs): - connector type - wire cross section (min...max) - minimum stripping length - screw tightening torque (min...max)	Phoenix Contact DFMC 1,5/6-STF-3,5 0.2...1.5 mm ² (24...15 AWG) 10 mm 0.2 Nm (1.8 lbf·in)
Connector X5 (when the device has Rogowski inputs): - connector type - wire cross section (min...max) - minimum stripping length - screw tightening torque (min...max)	Phoenix Contact MC 1,5/5-ST-3,81 0.08...1.5 mm ² (28...15 AWG) 7 mm 0.22...0.5 Nm (3.5...4.4 lbf·in)

Fiber connectors: - nut tightening torque	light finger tightening
--	-------------------------

13.2 Operating times

Table. 13.2 - 15. Technical data for relay operating times.

HSO operation delay	2 ms*
Trip relay operation delay	7 ms*
Reset time: - light stage - overcurrent stage	1 ms 50 ms

*) The total trip time when using both the arc light (L>) or phase/residual overcurrent (I>) from this device and the arc light (L>) from an AQ-101 variant or an AQ-102 device.

13.3 Auxiliary voltage

Table. 13.3 - 16. Technical data for the relay auxiliary voltage (Uaux).

Auxiliary power supply	92...265 V AC/DC 18...72 V DC (optional)
Maximum power consumption	5 W, < 10 mΩ
Standby current	90 mA
Start-up inrush current	<150 ms (110 V DC) <600 ms (24 V DC)

13.4 Current measuring circuits

Table. 13.4 - 17. Technical data for the current measurement circuits (IL1, IL2, IL3, I0).

Nominal current	1 A <u>or</u> 5 A
Rated frequency	2...1,000 Hz
Number of inputs	3 (phase) + 1 (residual)
Thermal withstand: - continuous - 10 s - 1 s	30 A 100 A 500 A
Overcurrent setting range: - phase overcurrent - residual overcurrent	0.5...6.0 × I _N 0.05...2.00 × I _N
Measurement accuracy	10 %
Rated AC burden (VA)	10 mΩ (input resistance)

Power consumption of current input circuit	< 10 mΩ
--	---------

13.5 Rogowski coil measurement inputs

Table. 13.5 - 18. Technical data for the Rogowski coil measurement inputs (IL1, IL2, IL3, I0).

Number of inputs	3 (phase) + 1 (residual)
Rated frequency (f_r)	50/60 Hz
Secondary voltage (U_s) for Option A: - at 50 Hz, $I_p = 1$ kA - at 60 Hz, $I_p = 1$ kA	22.5 mV 27 mV
Secondary voltage (U_s) for Option B: - at 50 Hz, $I_p = 1$ kA - at 60 Hz, $I_p = 1$ kA	100 mV 120 mV
Secondary voltage (U_s) for Option C: - at 50 Hz, $I_p = 1$ kA - at 60 Hz, $I_p = 1$ kA	333 mV 400 mV

13.6 Binary inputs

Table. 13.6 - 19. Technical data for the binary inputs (BI1, BI2).

Nominal threshold voltage	24 V DC
Threshold: - pick-up - drop-off	Approximately 16 V DC Approximately 15 V DC
Rated current	3 mA
Number of inputs	2

13.7 Trip relays

Table. 13.7 - 20. Technical data for the trip relays (T1, T2, T3, T4).

Number of trip relays	4 NO <u>or</u> 3 NO + 1 NC
Voltage withstand	250 V AC/DC
Carry: - continuous carry - make-and-carry for 3 s - make-and-carry for 0.5 s	5 A 16 A 30 A
Breaking capacity DC*	40 W (0.36 A at 110 V DC)
Contact material	AgNi 90/10

*) When the time constant $L/R = 40$ ms.

13.8 High-speed output(s)

Table. 13.8 - 21. Technical data for the high-speed outputs (HSO1, HSO2).

Number of outputs	2
Rated voltage	250 V DC
Carry: - continuous carry - make-and-carry for 3 s - make-and-carry for 0.5 s	2 A 6 A 15 A
Breaking capacity DC*	1 A/110 W
Contact material	Semiconductor

*) When the time constant $L/R = 40$ ms.

13.9 Binary output(s)

Table. 13.9 - 22. Technical data for the binary output (BO1).

Number of outputs	1
Rated voltage	+24 V DC (internal power supply)
Rated current (max.)	20 mA

13.10 System failure relay

Table. 13.10 - 23. Technical data for the system failure relay (SF).

Number of SF relays	1
Rated voltage	250 V AC/DC
Carry: - continuous carry - make-and-carry for 3 s - make-and-carry for 0.5 s	5 A 16 A 30 A
Breaking capacity DC*	40 W (0.36 A at 110 V DC)
Contact material	AgNi 90/10

*) When the time constant $L/R = 40$ ms.

13.11 Fiber optic loop sensors

AQ-06 fiber optic loop sensor

Table. 13.11 - 24. Technical data for the AQ-06 fiber optic loop sensor.

Material	Plastic fiber
Light intensity threshold	8,000 lux
Cable length (min...max)	3...40 m
Cable diameter	1.0 mm
Detection radius	360°
Bending radius	5 cm
Operating temperature	-40...+85 °C

AQ-07 fiber optic loop sensor

Table. 13.11 - 25. Technical data for the AQ-07 fiber optic loop sensor.

Material	Covered glass fiber
Light intensity threshold	8,000 lux
Cable length (min...max)	3...50 m
Cable diameter	1.2 mm
Detection radius	360°
Bending radius	1 cm
Operating temperature	-40...+85 °C

AQ-08 fiber optic loop sensor

Table. 13.11 - 26. Technical data for the AQ-08 fiber optic loop sensor.

Material	Covered glass fiber
Light intensity threshold	8,000 lux
Cable length (min...max)	3...15 m
Cable diameter	1.2 mm
Detection radius	360°
Bending radius	1 cm
Operating temperature	-40...+125 °C

13.12 Disturbance tests

Table. 13.12 - 27. Technical data for the disturbance tests.

Electromagnetic compatibility test	CE-approved and tested according to EN 50081-2 and EN 50082-2
Conducted emission (EN 55011, class A)	0.15...30.00 Hz
Radiated emission (EN 55011, class A)	30.00...1,000.00 MHz
Electrostatic discharge immunity (IEC 244-222 and EN 61000-4-2, level 4)	Air discharge: 15 kV Contact discharge: 8 kV
Electrical fast transients (EN 61000-4-4, class III & IEC 801-4, level 4)	Power supply input: 4 kV, 5/50 ns Other inputs and outputs: 4 kV, 5/50 ns
Surge immunity (EN 61000-4-5, level 4)	Between wires: 2 kV, 1.2/50 μ s Between wire and earth: 4 kV, 1.2/50 μ s
RF electromagnetic field (EN 61000-4-3, level 3)	f = 80...1,000 MHz, 10 V/m
Conducted RF field (EN 61000-4-6, level 3)	f = 150 kHz...80 MHz, 10 V/m

13.13 Voltage tests

Table. 13.13 - 28. Technical data for the voltage tests.

Insulation test voltage (IEC 60255-5)	2 kV, 50 Hz, 1 min
Impulse test voltage (IEC 60255-5)	5 kV, 1.2/50 μ s, 0.5 J

13.14 Mechanical tests

Table. 13.14 - 29. Technical data for the mechanical tests.

Vibration test	2...13.2 Hz (\pm 3.5 mm) 13.2...100 Hz (\pm 1.0 g)
Shock/bump test (IEC 60255-21-2)	20 g and 1,000 bumps/dir.

13.15 Environmental conditions

Table. 13.15 - 30. Technical data for the environmental conditions.

Specified ambient service temperature	-35...+70 °C
Transportation and storage temperature	-40...+70 °C

Relative humidity	Up to 97 %
Altitude	Up to 2,000 m above sea level

13.16 Casing

Table. 13.16 - 31. Technical data for the device casing.

Protection: - front - back	IP 52 IP 20
Device dimensions (W × H × D)	102 × 177 × 161 mm
Weight	1.2 kg

14 Ordering information

AQ-110F current measurement and arc sensing device

AQ-110F - X X X A X

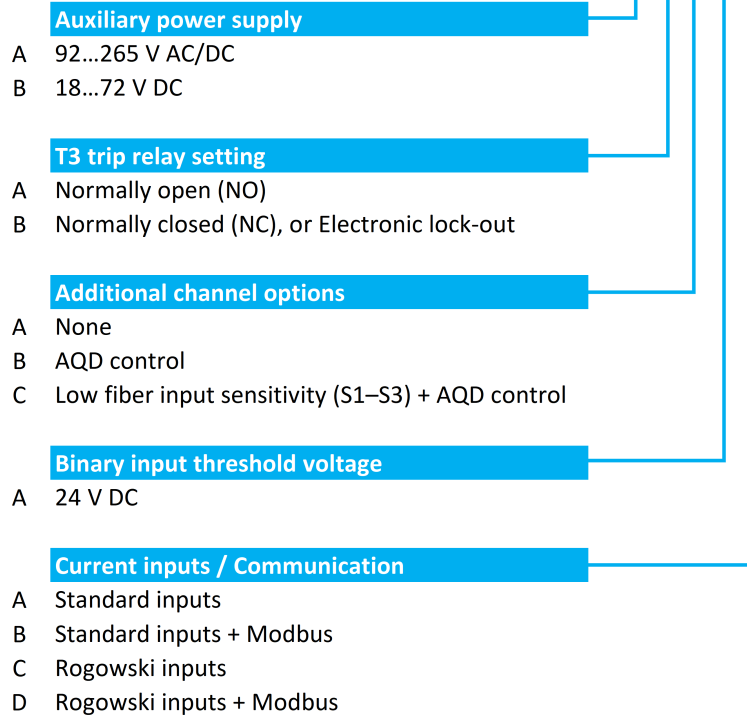

AQ-0x fiber optic loop sensors

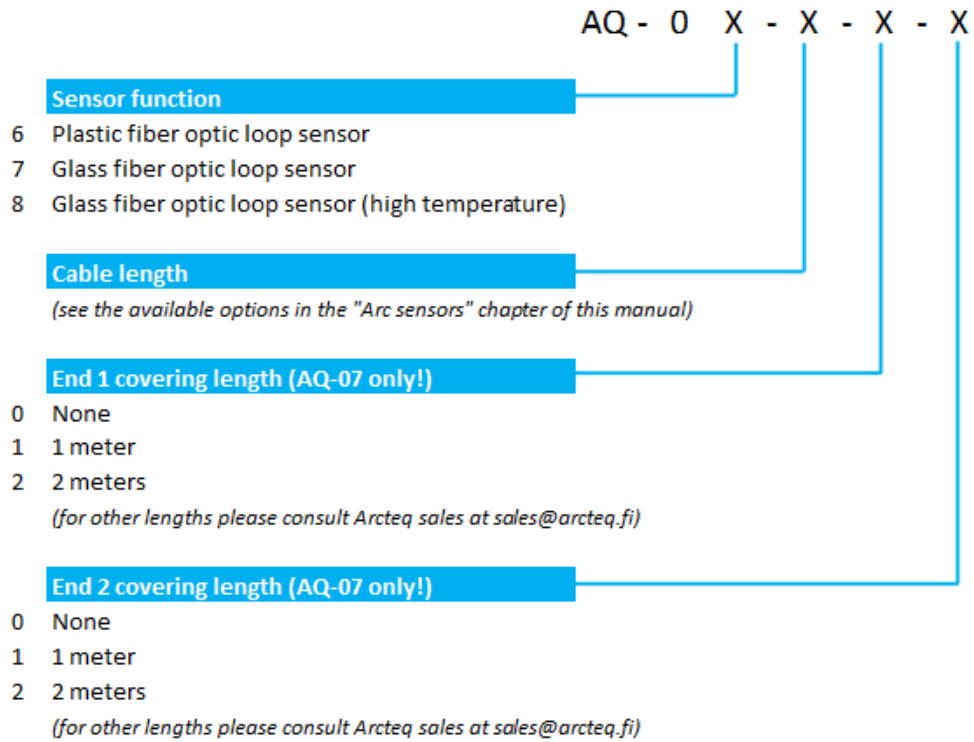

Accessories

Order code	Description	Note	Manufacturer
AX006	Wall mounting bracket	For AQ-103 and AQ-110x variants (MV and LV).	Arcteq Relays Ltd.
AX016	Wall mounting bracket	For AQ-101, AQ-101S and AQ-102 devices (MV and LV).	Arcteq Relays Ltd.
AX033	Sensor bracket		Arcteq Relays Ltd.

15 Contact and reference information

Manufacturer

Arcteq Relays Ltd.

Visiting and postal address

Kvartsikatu 2 A 1
65300 Vaasa, Finland

Contacts

Phone:	+358 10 3221 370
Website:	arcteq.com
Technical support:	arcteq.com/support-login +358 10 3221 388 (EET 9:00 – 17.00)
E-mail (sales):	sales@arcteq.fi