

# MDW-45

6617-2202

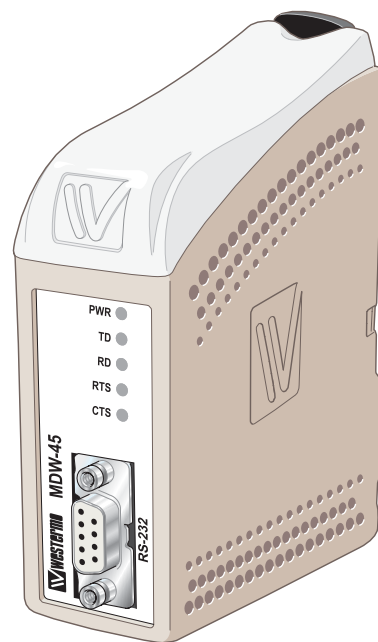

**Converter**  
**RS-232 – RS-422/485**

## Safety



### **Before using this unit:**

Read this manual completely and gather all information on the unit. Make sure that you understand it fully. Check that your application does not exceed the safe operating specifications for this unit.

Hazardous voltage may occur within this unit when connected to power supply or TNV circuits.

Prevent access to hazardous voltage by disconnecting the unit from power supply and all other electrical connections.

Prevent damage to internal electronics from electrostatic discharges (ESD) by discharging your body to a grounding point (e.g. use of wrist strap).



### **Before installation:**

This unit should only be installed by qualified personnel.

This unit should be built-in to an apparatus cabinet, or similar, where access is restricted to service personnel only.

The power supply wiring must be sufficiently fused, and if necessary it must be possible to disconnect manually from the power supply. Ensure compliance to national installation regulations.

This unit uses convection cooling. To avoid obstructing the airflow around the unit, follow the spacing recommendations (see Installation section).

## Maintenance

No maintenance is required, as long as the unit is used as intended within the specified conditions.

# Introduction

The MDW-45 is an RS-422/485 to RS-232 converter. This device can be used in multipoint and point to point applications to connect devices like PCs, PLCs, drives and other automation equipment.

In 2-wire half duplex applications (RS-485) the MDW-45 can automatically control the state of the data bus based just on the data it receives. This allows the unit to be used with equipment that has no handshaking signal. The maximum transmission rate possible is 115.2 kbit/s.

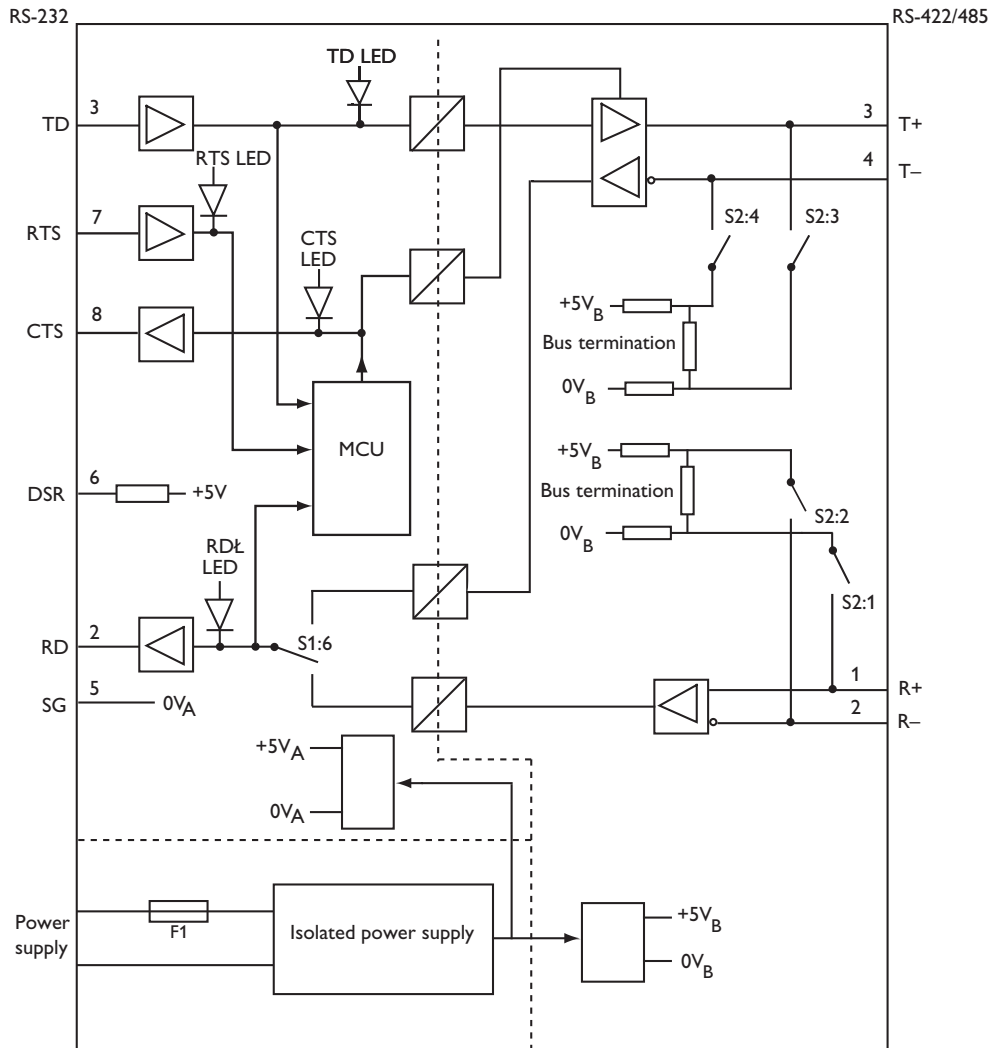

## Field of application

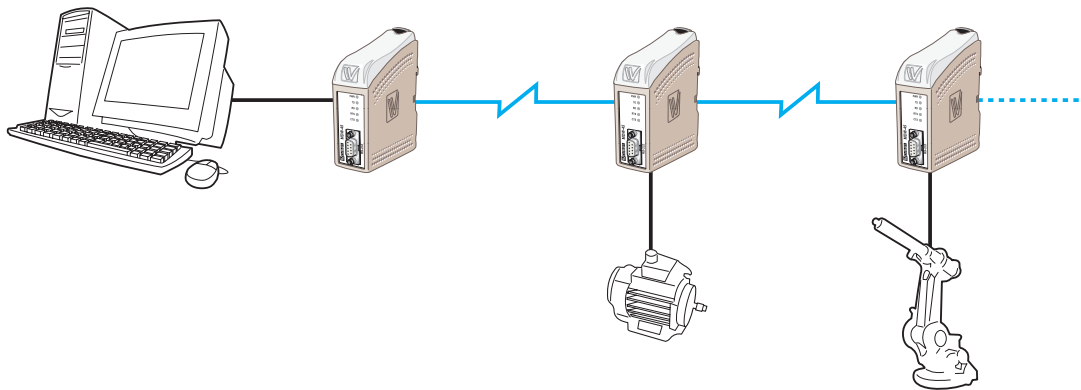

## Agency approvals and standards compliance

Type	Approval / Compliance	
EMC	EN 61000-6-2 EN 55024 EN 61000-6-3 FCC part 15 EN 50121-4 IEC 62236-4	Immunity industrial environments Immunity IT equipment Emission residential environments Class B Railway signalling and telecommunications apparatus Railway signalling and telecommunications apparatus
Safety	EN 60950	IT equipment

### FCC Part 15.105 Notice:

This equipment has been tested and found to comply with the limits for a Class B digital device, pursuant to Part 15 of the FCC Rules. These limits are designed to provide reasonable protection against harmful interference in a residential installation. This equipment generates, uses and can radiate radio frequency energy and, if not installed and used in accordance with the instructions, may cause harmful interference to radio communications. However, there is no guarantee that interference will not occur in a particular installation. If this equipment does cause harmful interference to radio or television reception, which can be determined by turning the equipment off and on, the user is encouraged to try to correct the interference by one or more of the following measures:

- ⌘ Reorient or relocate the receiving antenna.
- ⌘ Increase the separation between the equipment and receiver.
- ⌘ Connect the equipment into an outlet on a circuit different from that to which the receiver is connected.
- ⌘ Consult the dealer or an experienced radio/TV technician for help.

# Declaration of Conformity



Westermo Teleindustri AB

## Declaration of conformity

The manufacturer Westermo Teleindustri AB  
SE-640 40 Stora Sundby, Sweden

Herewith declares that the product(s)

Type of product	Model	Art no	Installation manual
DIN-rail	MDW-45 LV	3617-0001	6617-2202
DIN-rail	MDW-45 HV	3617-0101	6617-2202

is in conformity with the following EC directive(s).

No	Short name
89/336/EEG	Electromagnetic Compatibility (EMC)
73/23/EEG	Low Voltage Directive – LVD

References of standards applied for this EC declaration of conformity.

No	Title	Issue
EN 61000-6-2	Immunity for industrial environments	2 (2001)
EN 55024	Information technology equipment – Immunity	1 (1998)
EN 61000-6-3	Emission standard for residential, commercial and light-industrial environments	1 (2001)
EN 60950	Safety of information technology equipment	6 (2000)

The last two digits of the year in which the CE marking was affixed: 05

Herewith declares that product(s) listed above is in conformity with

No	Title	Issue
FCC part 15	Radio frequency devices	Dec. 2003
EN 50121-4	Railway applications & EMC: Emission and immunity of the signalling and telecommunications apparatus	1 (2000)
IEC 62236-4	Railway applications & Emission and immunity of signalling and telecommunications apparatus	1 (2003)

Hans Levin  
Technical Manager  
30th March 2005

Postaddress/Postal address  
S-640 40 Stora Sundby  
Sweden

Tel.  
016-428000  
Int+46 16428000

Telefax  
016-428001  
Int+46 16428001

Postgiro  
52 72 79-4

Bankgiro  
5671-5550

Org.nr/  
Corp. identity number  
556361-2604

Registered office  
Eskilstuna

## Type tests and environmental conditions

<b>Electromagnetic Compatibility</b>			
<b>Phenomena</b>	<b>Test</b>	<b>Description</b>	<b>Level</b>
ESD	EN 61000-4-2	Enclosure contact	± 6 kV
		Enclosure air	± 8 kV
RF field AM modulated	IEC 61000-4-3	Enclosure	10 V/m 80% AM (1 kHz), 80 – 1 000 MHz 20 V/m 80% AM (1 kHz), 800 – 960 MHz 20 V/m 80% AM (1 kHz), 1 400 – 2 000 MHz
RF field 900 MHz	ENV 50204	Enclosure	20 V/m pulse modulated 200 Hz, 900 ± 5 MHz
Fast transient	EN 61000-4-4	Signal ports	± 2 kV
		Power ports	± 2 kV
Surge	EN 61000-4-5	Signal ports unbalanced	± 2 kV line to earth, ± 2 kV line to line
		Signal ports balanced	± 2 kV line to earth, ± 1 kV line to line
		Power ports	± 2 kV line to earth, ± 2 kV line to line
RF conducted	EN 61000-4-6	Signal ports	10 V 80% AM (1 kHz), 0.15 – 80 MHz
		Power ports	10 V 80% AM (1 kHz), 0.15 – 80 MHz
Magnetic field, power freq.	EN 61000-4-8	Enclosure	100 A/m, 50 Hz, 16.7 Hz & 0 Hz
Pulse Magnetic field	EN 61000-4-9	Enclosure	300 A/m, 6.4 / 16 ms pulse
Voltage dips and interruption	EN 61000-4-11	AC power ports	10 & 5 000 ms, interruption 10 & 500 ms, 30% reduction 100 & 1 000 ms, 60% reduction
Mains freq. 50 Hz	EN 61000-4-16	Signal ports	100 V 50 Hz
Mains freq. 50 Hz	SS 436 15 03	Signal ports	250 V 50 Hz
Voltage dips and interruption	EN 61000-4-29	DC power ports	10 & 100 ms, interruption 10 ms, 30% reduction 10 ms, 60% reduction +20% above & -20% below rated voltage
Radiated emission	EN 55022	Enclosure	Class B
	FCC part 15		Class B
Conducted emission	EN 55022	AC power ports	Class B
	FCC part 15	AC power ports	Class B
	EN 55022	DC power ports	Class B
Dielectric strength		Signal port to all other	2 kVrms 50 Hz 1min
		Power port to all other	3 kVrms 50 Hz 1min 2 kVrms 50 Hz 1min (@ rated power < 60V)
<b>Environmental</b>			
Temperature		Operating	-40 to +70°C
		Storage & Transport	-40 to +70°C
Humidity		Operating	5 to 95% relative humidity
		Storage & Transport	5 to 95% relative humidity
Altitude		Operating	2 000 m / 70 kPa
Service life		Operating	10 year
Vibration	IEC 60068-2-6	Operating	7.5 mm, 5 – 8 Hz 2 g, 8 – 500 Hz
Shock	IEC 60068-2-27	Operating	15 g, 11 ms
<b>Packaging</b>			
<b>Phenomena</b>	<b>Test</b>	<b>Description</b>	<b>Level</b>
Enclosure	UL 94	PC / ABS	Flammability class V-1
Dimension W x H x D			35 x 121 x 119 mm
Weight			0.19 kg
Degree of protection	IEC 529	Enclosure	IP 21
Cooling			Convection
Mounting			Horizontal on 35 mm DIN-rail

## Interface specifications

<b>Power</b>		
	<b>MDW-45 LV</b>	<b>MDW-45 HV</b>
Rated voltage	12 to 48 VDC	95 to 240 VAC 110 to 250 VDC
Operating voltage	9.6 to 57.6 VDC	85.5 to 264 VAC 88 to 300 VDC
Rated current	95 mA @ 12 VDC 35 mA @ 48 VDC	21 mA @ 95 VAC 10 mA @ 110 VDC
Rated frequency	DC	48 – 62 Hz / DC
Polarity	Reverse polarity protected	Polarity independent
Connection	Detachable screw terminal	Detachable screw terminal
Connector size	0.2 – 2.5 mm <sup>2</sup> (AWG 24-12)	0.2 – 2.5 mm <sup>2</sup> (AWG 24-12)

### **RS-422/485**

Electrical specification	RS-485
Data rate	1 200 bit/s – 115.2 kbit/s
Data format	7 or 8 data bit, Odd, even or none parity, 1 or 2 stop bit
Connection	Detachable screw terminal
Connector size	0.2 – 2.5 mm <sup>2</sup> (AWG 24-12)
Transmission range	In accordance with EIA RS-485 ≤1200 m, depending on data rate and cable type
Settings	120 Ω termination and failsafe biasing 680 Ω, by DIP-switch
Protection	Installation Fault Tolerant (up to ±60 V)

### **RS-232**

Electrical specification	RS-232
Data rate	1 200 bit/s – 115.2 kbit/s
Data format	7 or 8 data bit, Odd, even or none parity, 1 or 2 stop bit
Connection	9-pin D-sub female DCE
Transmission range	15 m

## Mounting

This unit should be mounted on 35 mm DIN-rail, which is horizontally mounted inside an apparatus cabinet, or similar.

Snap on mounting, see figure.

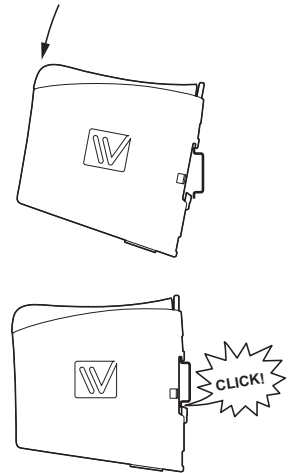

## Cooling

This unit uses convection cooling. To avoid obstructing the air-flow around the unit, use the following spacing rules. Minimum spacing 25 mm (1.0 inch) above /below and 10 mm (0.4 inches) left /right the unit. Spacing is recommended for the use of unit in full operating temperature range and service life.

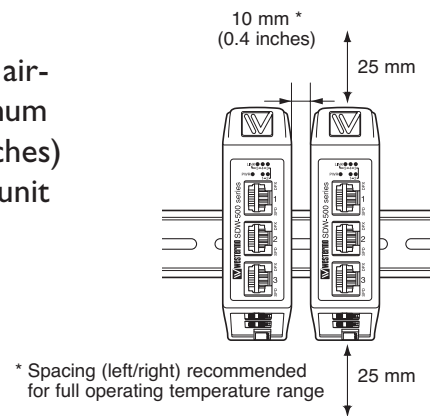

## Removal

Press down the black support at the top of the unit. See figure.

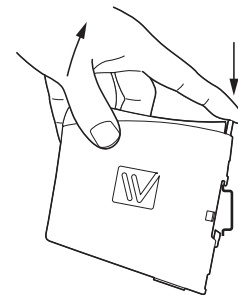

## LED Indicators

LED	Status	Description
PWR	ON	In service
	OFF	Out of service
TD	ON	Transmitted Data: Displays data received from the local RS-232 port
	OFF	No data
RD	ON	Received Data: Displays data leaving the modem on the RS-232 port
	OFF	No data
RTS	ON	Status of RTS from the RS-232 interface
	OFF	No RTS
CTS	ON	Status of CTS from the RS-232 interface
	OFF	No CTS

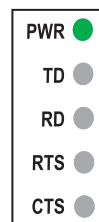



## Connections

**S1** DIP-switch under lid  
(for details see page 10)

LED indicators  
(for details see page 8)

**S2** DIP-switch  
Termination  
(for details see page 11)

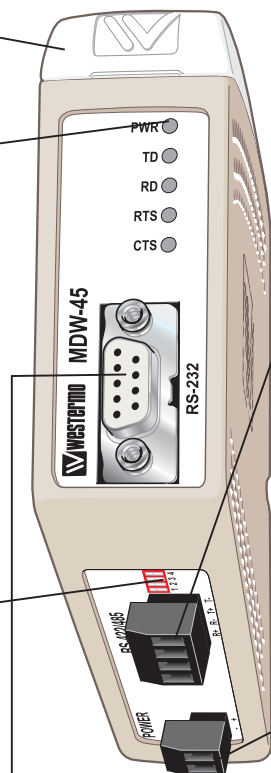



### RS-422/485 interface screw terminal

4-position	Direction*	Description
No. 1	In	R+ line RS-422
No. 2	In	R- line RS-422
No. 3	In/Out	T+ line RS-422/485
No. 4	In/Out	T- line RS-422/485

### Power connection, LV screw terminal

2-position	Description
No. 1	0 VDC
No. 2	12 – 48 VDC

### Power connection, HV screw terminal

2-position	Description	Product marking
No. 1 	AC: Neutral DC: -Voltage	N/-
No. 2 	AC: Line DC: +Voltage	L/+

### RS-232 (DCE)

9-position	Direction	Description
No. 1	–	
No. 2	Out	Received Data (RD)
No. 3	In	Transmitted Data (TD)
No. 4	–	
No. 5	–	Signal Ground (SG)
No. 6	Out	Data Set Ready (DSR)
No. 7	In	Request To Send (RTS)
No. 8	Out	Clear To Send (CTS)
No. 9	–	

### Railway installation close to the rails (RS-232, RS-422/485)

For a cable located inside 3 m boundary and connected to this port, the use of shielded cable is recommended, this to minimize the risk of interference. The cable shield should be properly connected (360°) to an earthing point within 1 m from this port. This earthing point should have a low impedance connection to the conductive enclosure of the apparatus cabinet, or similar, where the unit is built-in. This conductive enclosure should be connected to the earthing system of an installation and may be directly connected to the protective earth.

# DIP-switch settings



## Before DIP-switch settings:

Prevent damage to internal electronics from electrostatic discharges (ESD) by discharging your body to a grounding point (e.g. use of wrist strap).

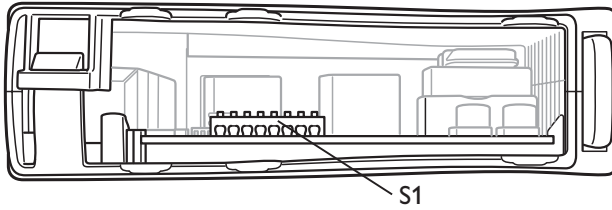

### Selection of data rate

- S1 1200 bit/s
- S1 2400 bit/s
- S1 4800 bit/s
- S1 9600 bit/s
- S1 19.2 kbit/s
- S1 38.4 kbit/s
- S1 57.6 kbit/s
- S1 115.2 kbit/s

### Selection of data format

- S1 9 bit format\*
- S1 10 bit format\*
- S1 11 bit format\*
- S1 12 bit format\*

Supervision table when selecting data format

7 bit		●	●	●		●		
8 bit					●		●	●
No parity	●	●		●		●		
Parity			●		●		●	●
1 stop bit	●		●	●			●	
2 stop bit		●			●	●		●
Number of bit	9	10	10	10	11	11	11	12

\* See Supervision table when selecting data bits.  
Turning time 1 – 1.5 bit time

### Selection of bus format

- S1 2-wire RS-485
- S1 4-wire RS-422

In RTS-control and Transmitter always active. The switches for data rate and number of bits has no effects.

### Selection of bus control

- S1 Data control
- S1 RTS-control
- S1 Transmitter always active

### S2 Below panel, RS-422/485 termination



No termination and fail-safe



Termination with fail-safe (2-wire)



Termination with fail-safe (4-wire)

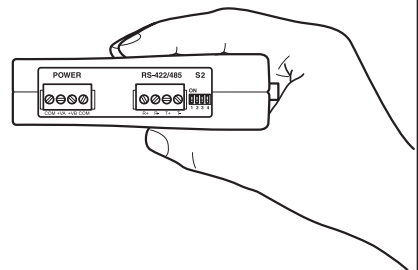

**Note!** DIP-switch alterations are only effective after a power on.

### Factory settings



S1

Data rate – 9600 bit/s, data format – 10 bit  
Bus format, 2-wire

**Note:** Switch 1:8 is not used



S2

No termination  
and fail-safe

## Unit specific description

When the converter is set to data-control mode the transmitter is activated by data on TD (RS-232). The time the transmitter stays active corresponds to one character-time plus the turning time for the set data rate and number of bits. If more data arrives on TD before the turning time has expired the transmitter stays active for an additional one character time and so on. In RTS-control mode the transmitter is activated by the RS-232 RTS-signal. In this mode the dip-switches for data rate and number of bits have no effect. The LED indicators show the status of the data signals. The fail-safe termination ensures that the signal level at the receiver is in 'mark state' (differential > 0.2 Volts) when there is no data on the RS-485 bus. Full duplex is only possible if 4-wires are used.

## Field of application

RS-422 and RS-485 were both designed for multidrop applications. When a system is installed it should always form a bus structure (see diagrams). Star shaped networks should never be created; there are other Westermo products that can be used to create star net applications. To install a system according to the RS-422/485 specification it is very important that the line is terminated at the correct points. The recommendation is to terminate the receiver on the master unit and the final bus slave unit. See diagrams for details of how this is done with RS-485 (2-wire) and RS-422 (4-wire).

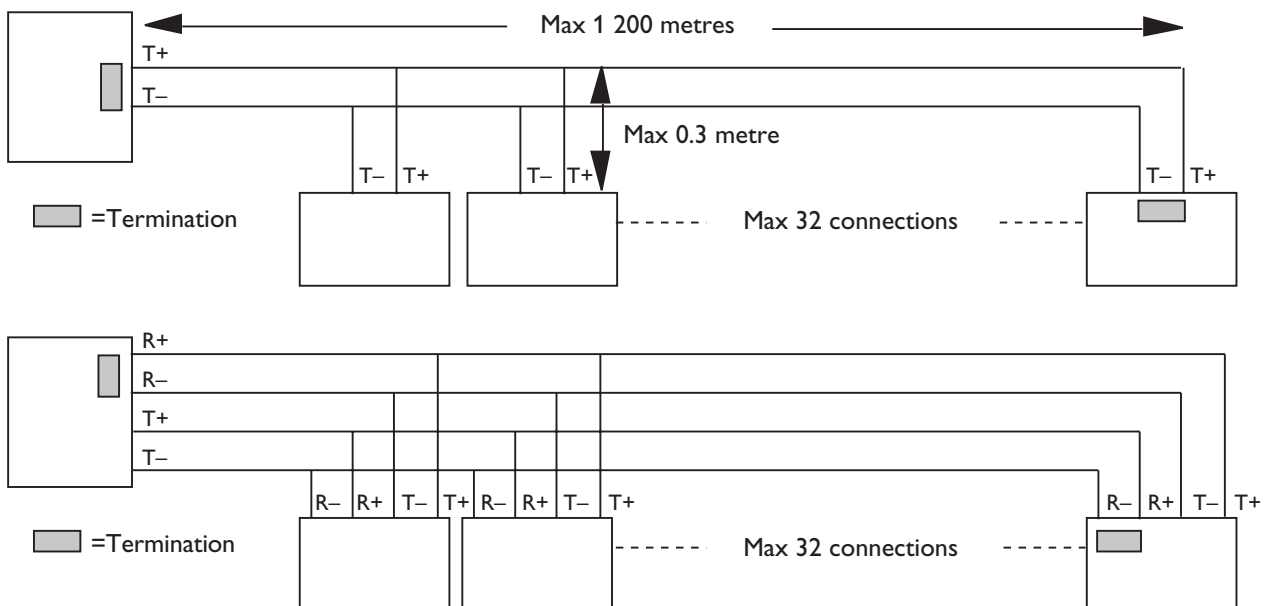

**N.B.** R+/R-, T+/T- definitions are not standard, it can help to shift + and - if the unit does not work.

## Line connection

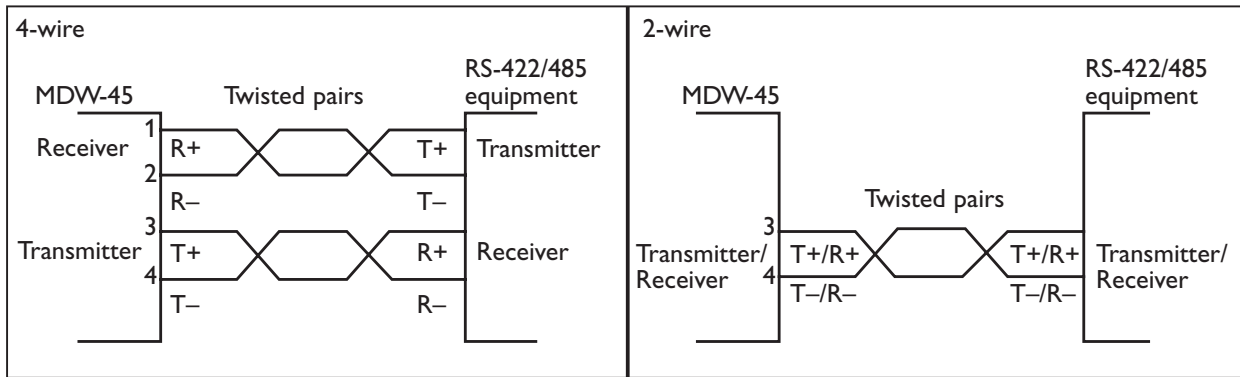

## Care recommendations

Follow the care recommendations below to maintain full operation of unit and to fulfill the warranty obligations.

- ⌘ This unit must not be operating with removed covers or lids.
- ⌘ Do not attempt to disassemble the unit.
- ⌘ There are no user serviceable parts inside.
- ⌘ Do not drop, knock or shake the unit, rough handling above the specification may cause damage to internal circuit boards.
- ⌘ Do not use harsh chemicals, cleaning solvents or strong detergents to clean the unit.
- ⌘ Do not paint the unit. Paint can clog the unit and prevent proper operation.
- ⌘ Do not expose the unit to any kind of liquids (rain, beverages, etc).  
The unit is not waterproof. Keep the unit within the specified humidity levels.
- ⌘ Do not use or store the unit in dusty, dirty areas, connectors as well as other mechanical part may be damaged.

If the unit is not working properly, contact the place of purchase, nearest Westermo distributor office or Westermo Tech support.





## Application example

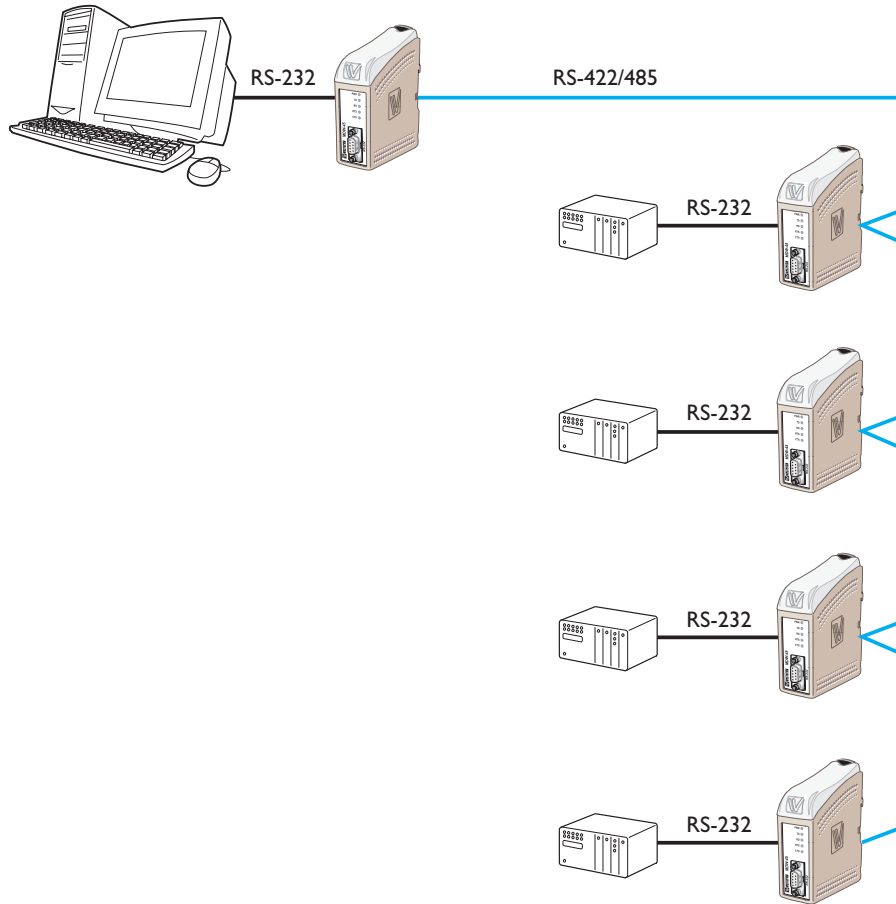

Westermo Teleindustri AB • SE-640 40 Stora Sundby, Sweden

Phone +46 16 42 80 00 Fax +46 16 42 80 01

E-mail: [info@westermo.se](mailto:info@westermo.se)

Westermo Web site: [www.westermo.com](http://www.westermo.com)

### Subsidiaries

Westermo Data Communications Ltd  
Talisman Business Centre • Duncan Road  
Park Gate, Southampton • SO31 7GA  
Phone: +44(0)1489 580 585 • Fax: +44(0)1489 580586  
E-Mail: [sales@westermo.co.uk](mailto:sales@westermo.co.uk)

Westermo Data Communications GmbH  
Goethestraße 67, 68753 Waghäusel  
Tel.: +49(0)7254-95400-0 • Fax: +49(0)7254-95400-9  
E-Mail: [info@westermo.de](mailto:info@westermo.de)

Westermo Data Communications S.A.R.L.  
9 Chemin de Chilly 91160 CHAMPLAN  
Tél : +33 1 69 10 21 00 • Fax : +33 1 69 10 21 01  
E-mail : [infos@westermo.fr](mailto:infos@westermo.fr)

*Westermo Teleindustri AB have distributors in several countries, contact us for further information.*