

JetCon 3701GP-U

Industrial Gigabit PoE Media Converter

User's Manual

Version: 1.0

Date: April 2019

Declaration of CE

This product has passed the CE certification for environmental specifications. Test conditions for passing included the equipment being operated within an industrial enclosure. In order to protect the product from being damaged by ESD (Electrostatic Discharge) and EMI leakage, we strongly recommend the use of CE-compliant industrial enclosure products.

Federal Communications Commission (FCC) Statement

This equipment has been tested and found to comply with the limits for a Class A digital device, pursuant to Part 15 of the FCC Rules. These limits are designed to provide reasonable protection against harmful interference when the equipment is operated in a commercial environment. This equipment generates, uses, and can radiate radio frequency energy and, if not installed and used in accordance with the instruction manual, may cause harmful interference to radio communications. Operation of this equipment in a residential area is likely to cause harmful interference in which case the user will be required to correct the interference at his expense.

The user is cautioned that changes and modifications made to the equipment without approval of the manufacturer could void the user's authority to operate this equipment

Index

1. Introduction.....	1
1-1. Features	2
1-2. Package Checklist.....	2
2. Hardware Description	3
2-1. Dimensions	3
2-2. Front Panel.....	4
2-3. Bottom View	5
2-4. Wiring the DC Power Inputs	6
2-5. Connect the Dry Relay Output.....	7
2-6. LED Indicators.....	7
2-7. Ports.....	8
3. Mounting Installation.....	10
3-1. DIN-Rail Mounting	10
4. System Configuration	11
4-1. Quality of Service	11
4-2. Packet Filtering.....	13

4-3. Link Loss Forwarding (L.L.F.)	13
4-4. Event Alarm Relay Configuration.....	14
5. System Installation	16
5-1. Installation and Testing.....	16
6. Troubles shooting	19

1. Introduction

This document describes the method of how to use the Korenix JetCon 3701GP-U Industrial Gigabit PoE media converter, includes installation the specifications that it has. Following this user manual, you can get fully imagination about JetCon 3701GP-U and all information to help you construct the network infrastructure. The following are brief introduction of JetCon 3701GP-U.

Real Industrial Gigabit Ethernet Media Converter

The JetCon 3701GP-U industrial Gigabit PoE media converter equipped a rugged aluminum alloy case with thirty-one grade ingress protection to against damaged solid objects or dust; With the excellent characteristics of heat dissipation, JetCon 3701GP-U has better survive ability than ordinary Gigabit PoE media converter which is enclosure by steel metal with various of heat dissipation holes. Not only single power input, the functionality of real time redundant power backup results in a real Industrial Gigabit PoE Media Converter with a non-stop transmission.

Flexible Optical adopt ability

As the trend of fiber interface, JetCon 3701GP-U combines a hot-swappable socket for Small Form-factor Pluggable (SFP) fiber transceiver. To adopt different type of fiber optical cable or enlarge fiber network campus, the JetCon 3701GP-U just need replace new fiber transceiver to meet the specification of optical fiber cable and achieve best inventory performance.

Activate Fault Alarm

Most of Gigabit PoE Media converter features Link Loss Forwarding function (L.L.F.) to forward link status change to alert remote or central management system. However, this is only for the cable event and is not enough for industrial network application. The JetCon 3701GP-U provides an alarm relay to trigger out a real alarm signal for power event. The alarm mechanism can be triggered by an external alarm equipment to inform

maintenance I.T. engineers. It makes a result of maintenance time saving.

Excellent Traffic Handling

The JetCon 3701GP-U supports graceful traffic management ability. All of traffic will be forwarded by the packet precedence or priority ID and result as different service priority. Besides, it also filter unnecessary broadcast packet by broadcast storm control and drop abnormal packet to enlarge network performance

1-1. Features

- One 10/100/1000Base-T RJ-45 and one 100/1000 SFP socket
- IEEE802.3, 802.3u, 802.3z and 802.3ab Compliance
- Auto detection Gigabit Transmission Media
- Flexible Gigabit Fiber Link Distance
- IEEE802.3af/ IEEE802.3at/IEEE 802.3bt compliance
- Supports Auto MID/MDI-X with Flow control
- IEEE802.1p for Quality of Service (QoS)
- Power redundancy with wide range input
- Rigid IP-31 grade Aluminum Case
- -40~75°C Wide Operating Temperature

1-2. Package Checklist

JetCon 3701GP-U package includes the following items:

- JetCon 3701GP-U x1
- One DIN-Rail clip (already screwed on the back of JetCon 3701GP-U) x1



JetCon 3701GP-U

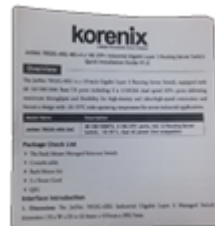

Quick Installation Guide

Contact your sales representative if any item is missing or damaged.

2. Hardware Description

2-1. Dimensions

The dimension of JetCon 3701G is **120 mm(H) x 30 mm (W) x99 mm (D)** (with DIN rail clip

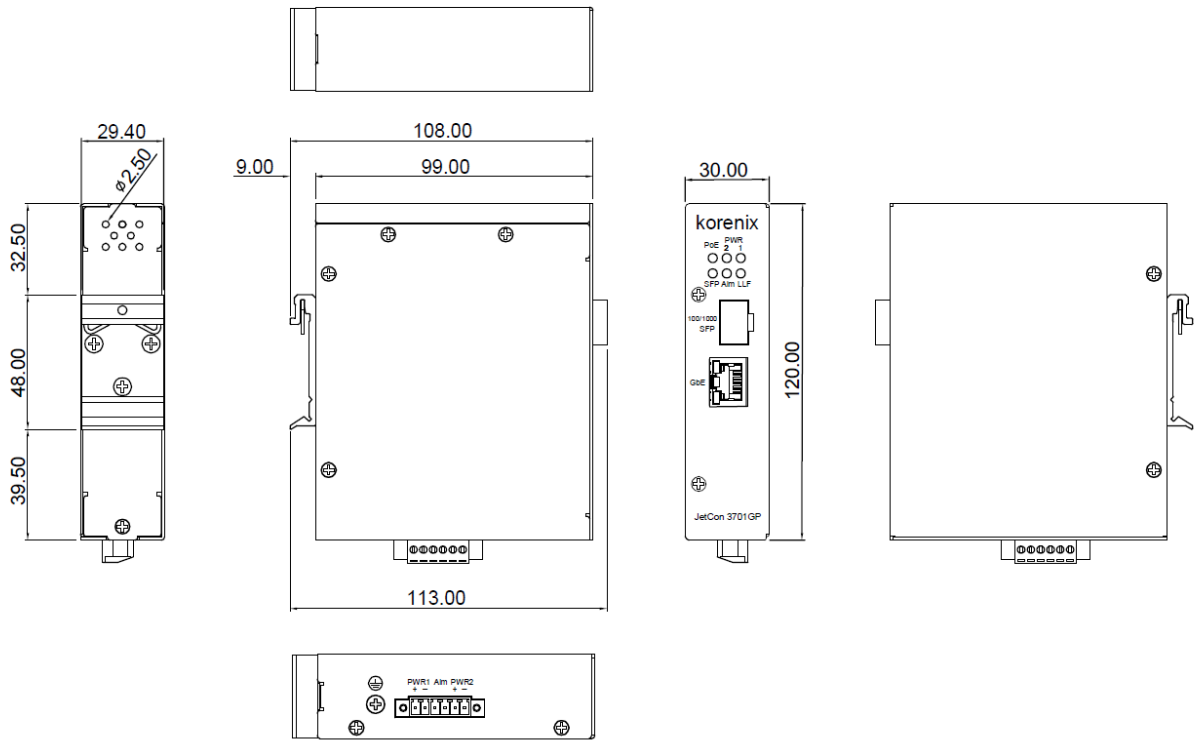

2-2. Front Panel

The Front Panel of the JetCon 3701GP-U Industrial Gigabit PoE Media Converter is shown in Figure A

Figure A

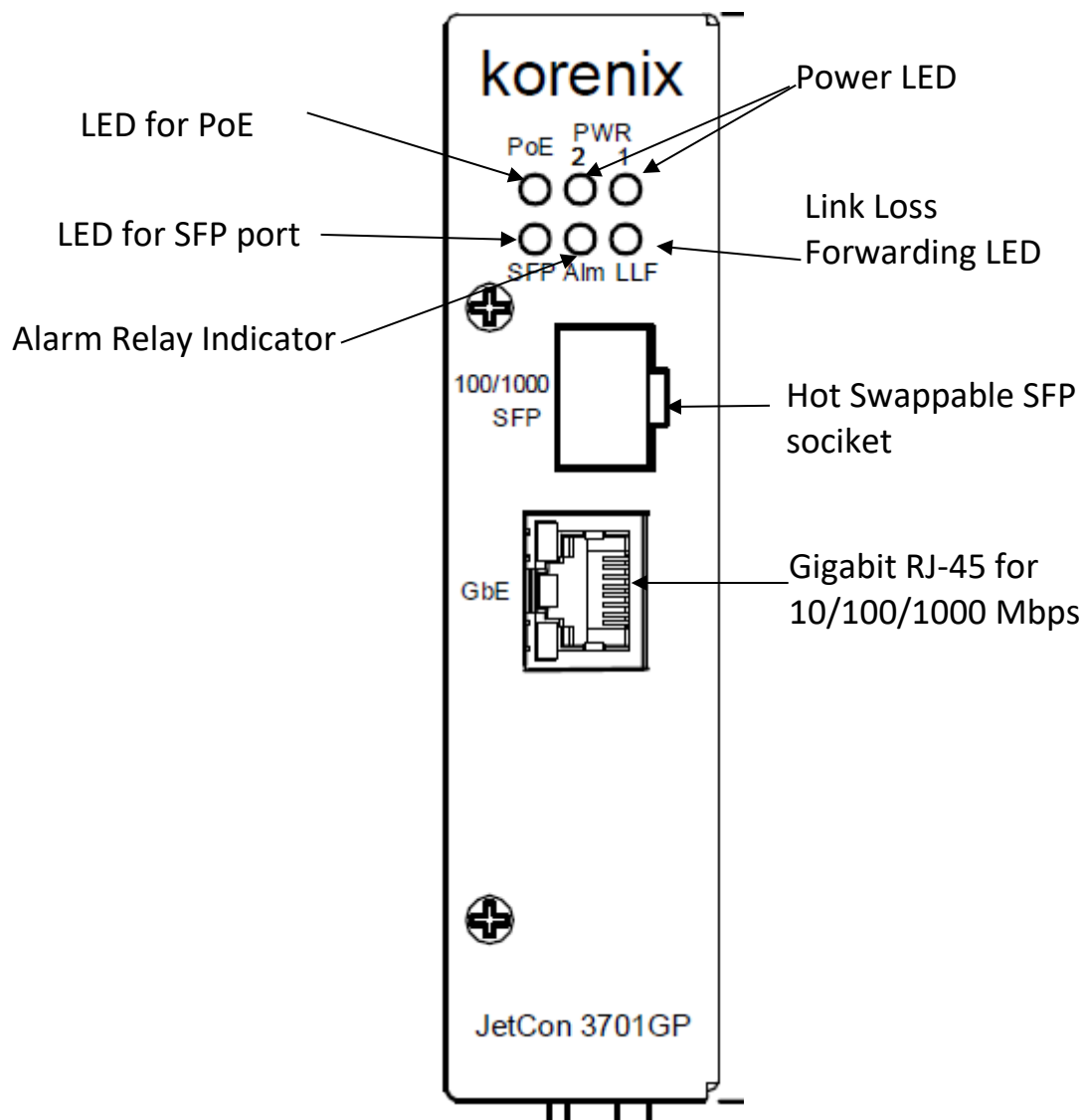

2-3. Bottom View

The bottom side of the JetCon 3701GP-U includes one 6-pin removable terminal block connector.

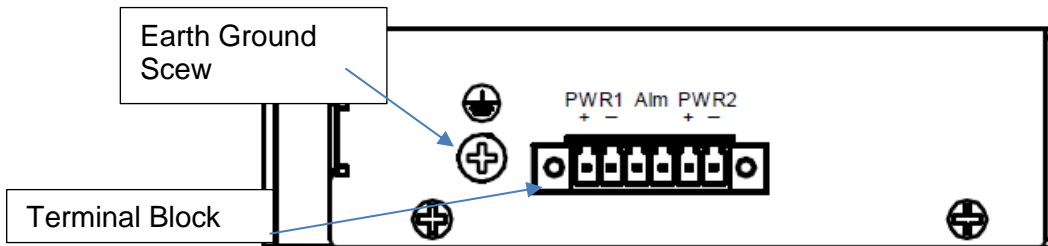

The power range of JetCon 3701GP-U is from DC 44~57V with redundancy and polarity reverse function.

To prevent interference and get better performance, it is strongly suggest make a well earth grounding by the “Earth Ground Screw”.

2-4. Wiring the DC Power Inputs

Follow the steps below to wire JetCon 3701GP-U redundant DC power inputs.

[Note] The suitable electric wire ranges from 12 to 23 AWG.

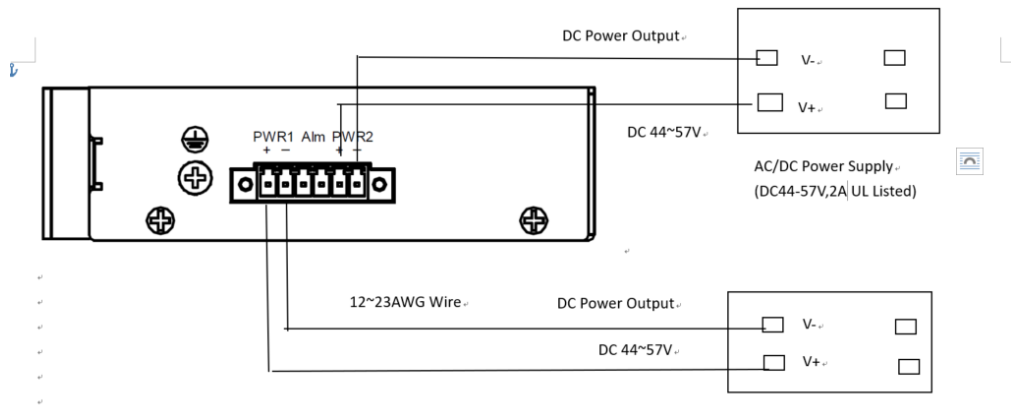

1. Insert the positive and negative wires into the V+ and V- contacts respectively of the terminal block connector
2. Tighten the wire-clamp screws to prevent the DC wires from being loosened.
3. The Power 1 and Power 2 support power redundancy and polarity reverse protection functions.
4. It accepts positive or negative power system input, but Power 1 and Power 2 have to apply the same mode.

2-5. Connect the Dry Relay Output

JetCon 3701GP-U provides one dry relay output for fault power event.

The relay conductor ability is 24W when it connects with a DC 24V power source and maximum current is 1A. In the following diagram shows how to make an alarm circuit.

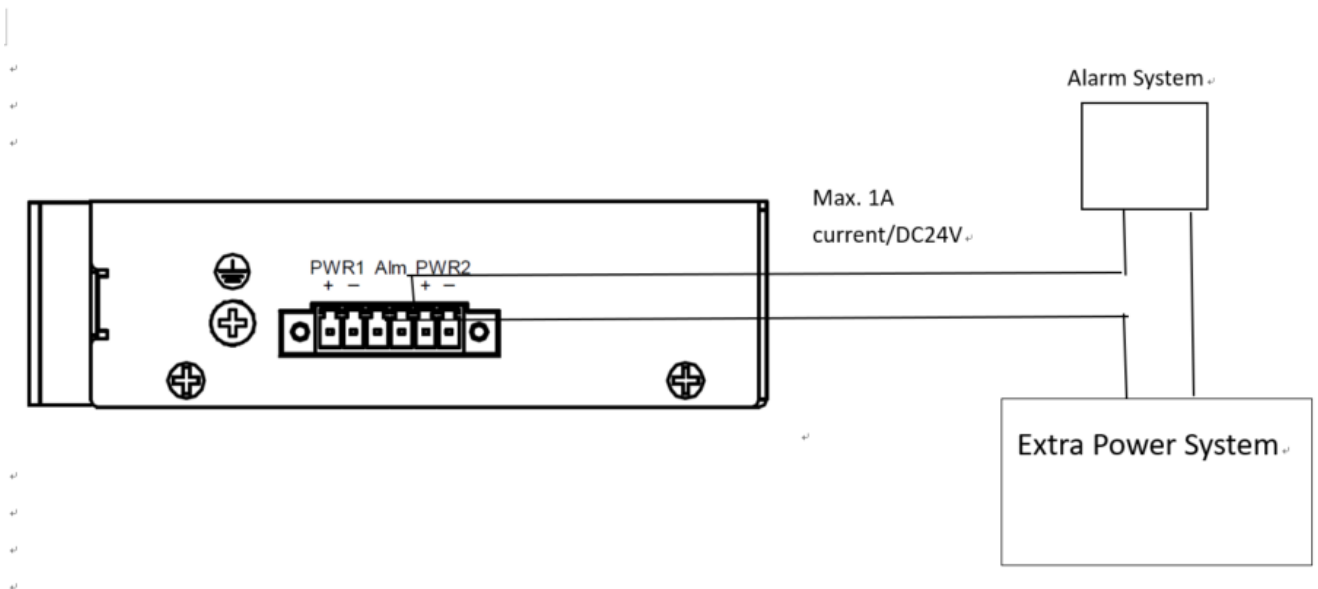

About the relay function, please refer section 4-4

2-6. LED Indicators

The front panel of JetCon 3701GP-U includes 2 Power LEDs, 1 LED for Alarm Relay, 1 LED for Link Loss Forwarding status and 1 LED for port link status. Following table gives descriptions of the function for each LED indicator.

LED	Status	Description
Power 1	Green On	Power 1 is supplying DC power.
	Off	No power is being supplied.
Power 2	Green On	Power 2 is supplying DC power.
	Off	No power is being supplied.
PoE	Amber On	Output power is supplied
	Amber Off	No output power
LLF (Link Loss Forwarding)	Red On	Link Loss
	Off	Data Transfer
Alarm	Red on	PW1 or PW2 is disconnect.
	Off	PW1 and PW2 Power Connect
SFP	Green on	Link
	Fast Blinking	Link with speed 1000Mbps
	Slow Blinking	Link with speed 100Mbps
RJ-45 port	Green On	Link
	Bilking	Activity
	Amber On	Link with Speed 1000Base T(X)
	Amber Off	Link with Speed 10/100 Base T(X)

Table 1

2-7. Ports

The JetCon 3701GP-U supports IEEE 802.3 10Base-T, IEEE 802.3u 100Base-T, IEEE 802.3ab 1000Base-T and IEEE 802.3z for Gigabit Fiber. This section will introduce how to wiring, install the Ethernet Cable for RJ-45 connector and SFP ports.

Gigabit TX (RJ-45 connector)

All of RJ-45 ports will auto detect 10Base-T and 100Base-TX or 1000Base-T

(Gigabit RJ45 only) connections. Auto MDI/MDIX allows users to connect another switch or workstation without changing straight through or crossover cabling. See Figure A, B, C and D for the schematic diagram of straight through and crossover cabling.

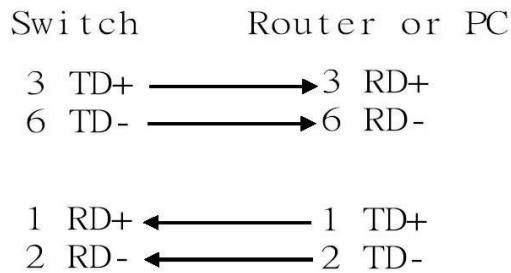

Fig A. Straight through Cabling Schematic for 10/100Mbps

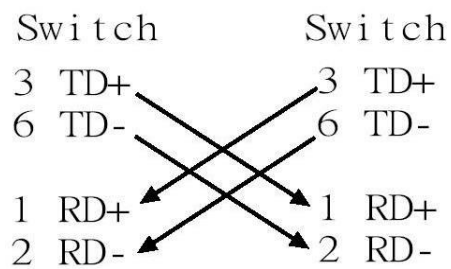

Fig B. Cross Over Cabling Schematic for 10/100Mbps

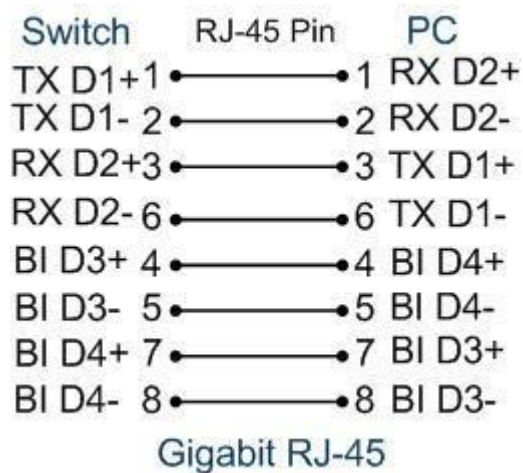

Fig. C Straight through cable schematic for 1000Mbps

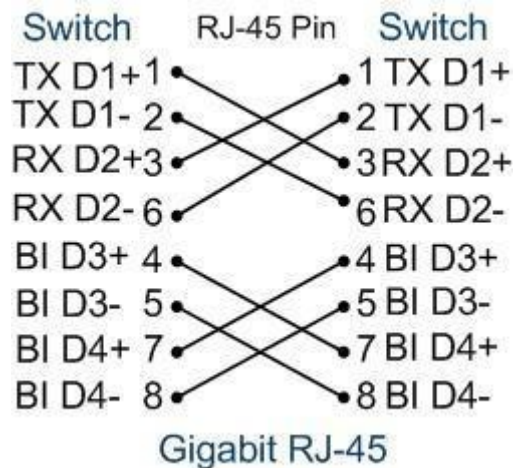

Fig. D Cross over cable schematic for 1000Mbps

The RJ-45 ports of JetCon 3701GP-U supports auto-MDI/MDI-X function without any cable change when you use an Ethernet cable to connect other devices, such as computers, switches or hubs.

Gigabit SFP port

The SFP port supports hot swappable function and user can change SFP fiber transceiver without system power off. This feature is useful for field site install if the fiber signal cannot attach the other end device, just change the different SFP transceiver type which with large power launch power budget. SFP port support 100/1000Mbps.

The Korenix provides various type of SFP transceiver for your application. Please refer the order information.

3. Mounting Installation

3-1. DIN-Rail Mounting

The DIN-Rail clip is already attached on the rear side of JetCon 3701GP-U. JetCon 3701GP-U supports EN 50022 standard DIN Rail, in the following diagram includes the dimension of EN 50022 DIN Rail for your reference.

The DIN rail should behind the spring when install the JetCon 3701GP-U onto the standard DIN Rail.

Follow the steps below to mount the JetCon 3701GP-U to the DIN-Rail track.

1. Insert the upper end of the DIN-Rail clip into the back of the DIN-Rail track from its upper side
2. Lightly push the bottom of the DIN-Rail clip into the track.
3. Check if the DIN-Rail clip is tightly attached to the track.
4. To remove the JetCon 3701GP-U from the track, reverse the steps above.

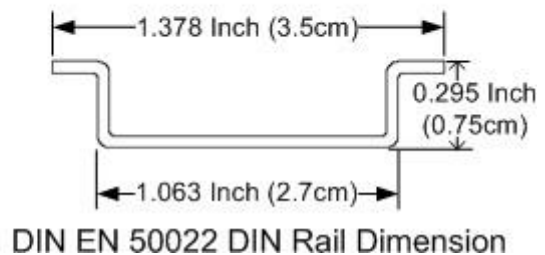
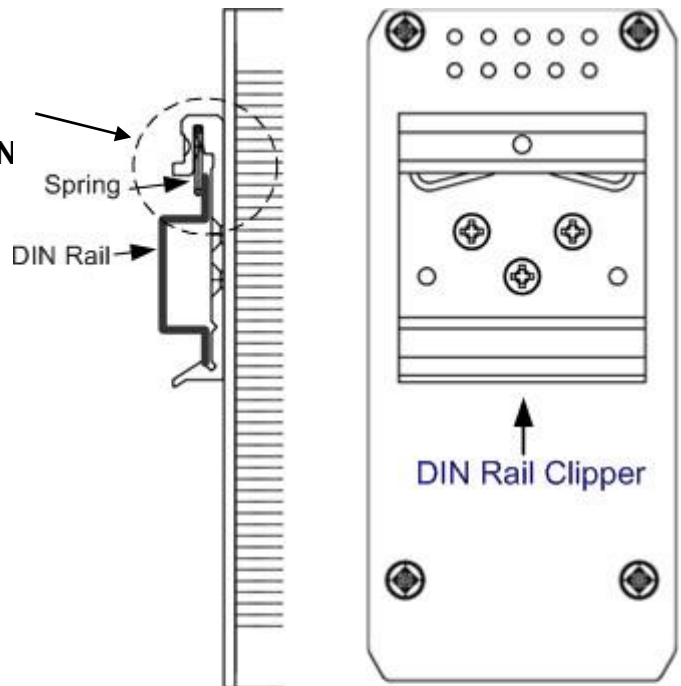

DIN EN 50022 DIN Rail Dimension

4. System Configuration

The JetCon 3701GP-U provides Ethernet signal transfer function from electrical to optical and various packet handling and cable diagnostic features. In this chapter, we will introduce how to configure those functions and benefits as following topics.

- 4-1. Quality of Service (QoS)
- 4-2. Packet filtering
- 4-2. Link Loss Forwarding (LLF)
- 4-3. Event Alarm Relay Configuration

4-1. Quality of Service

The JetCon 3701GP-U supports 2 types of priority mechanisms - IEEE802.1Q priority tag based CoS and ToS of IPv4. All the packets will be examined and forwarding into high or low priority queues. The Quality of Service function is pre-configured as enabled.

The weight round robin (WRR) ratio of high/low queue is 8:1. After 8 high priority packets were progressed then 1 low priority packets.

IEEE 802.1Q tag-based CoS

The JetCon 3701GP-U will examine the 3 bits of priority field carried by a VLAN tag and map it to the corresponding priority. A packet with priority field ranging from 0 to 3 will be treated as a low priority packet and will be stored in low priority queue. A packet with priority field ranging from 4 to 7 will be treated as a high priority packet, and will be stored in high priority query

IEEE 802.1Q Type of Service for IPv4 /IPv6 packet

JetCon 3701GP-U provides the IP layer ToS function by recognizing the priority octet and mapping it to the corresponding priority. For an IPv4 packet, it is embedded in the TOS (type of Service) Octet. For an IPv6 data packet, the Traffic Class Octet is used to differentiate the Class of Service. When this function is enabled, the JetCon 3701GP-U will automatically recognize the IP version and capture the either the TOS field (IPv4) or Traffic Class field (IPv6).

IPv4 frame format

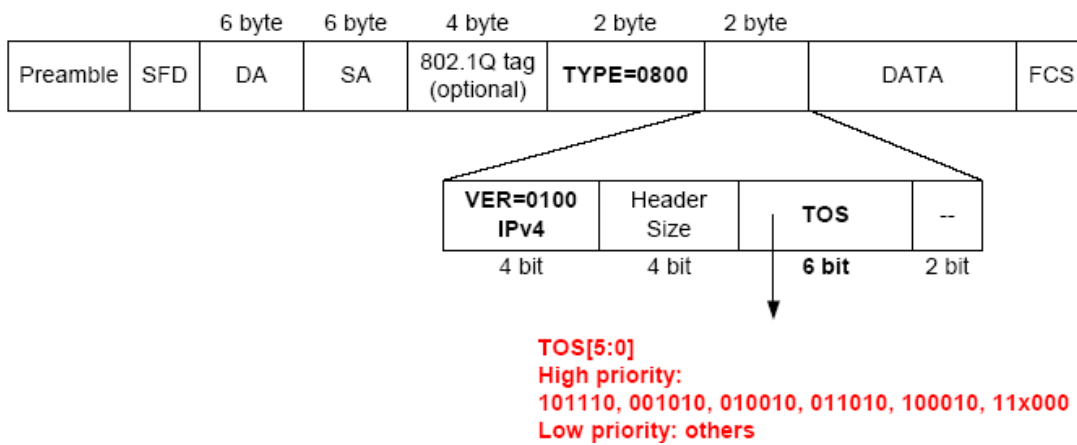

IPv6 frame format

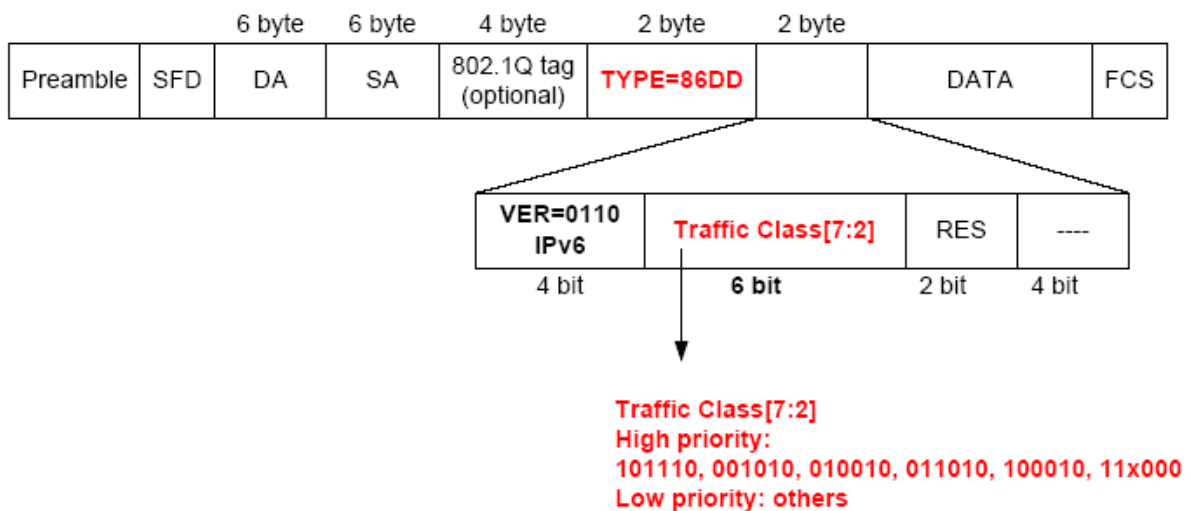

4-2. Packet Filtering

To prevent broadcast packet flooding on the network, the JetCon 3701GP-U have implemented broadcast packet control function. The port begins to drop incoming broadcast packets if the received broadcast packet counts reach the threshold as different link speed – 25Mbps at link speed 1000Mbps, 10Mbps at link speed 100Mbps and 1Mbps at link speed 10Mbps.

4-3. Link Loss Forwarding (L.L.F.)

The Link Loss Forwarding provides a real time hardware-based network activated diagnostics mechanism. In usually, the Gigabit Media Converter on the end of fiber cable should be equipped LLF function to provide better network performance and reduce the maintenance cost.

The JetCon 3701GP-U provides 2-way Link Loss Forwarding function. About the Link Loss Forwarding behaviors are described in following, please refer it.

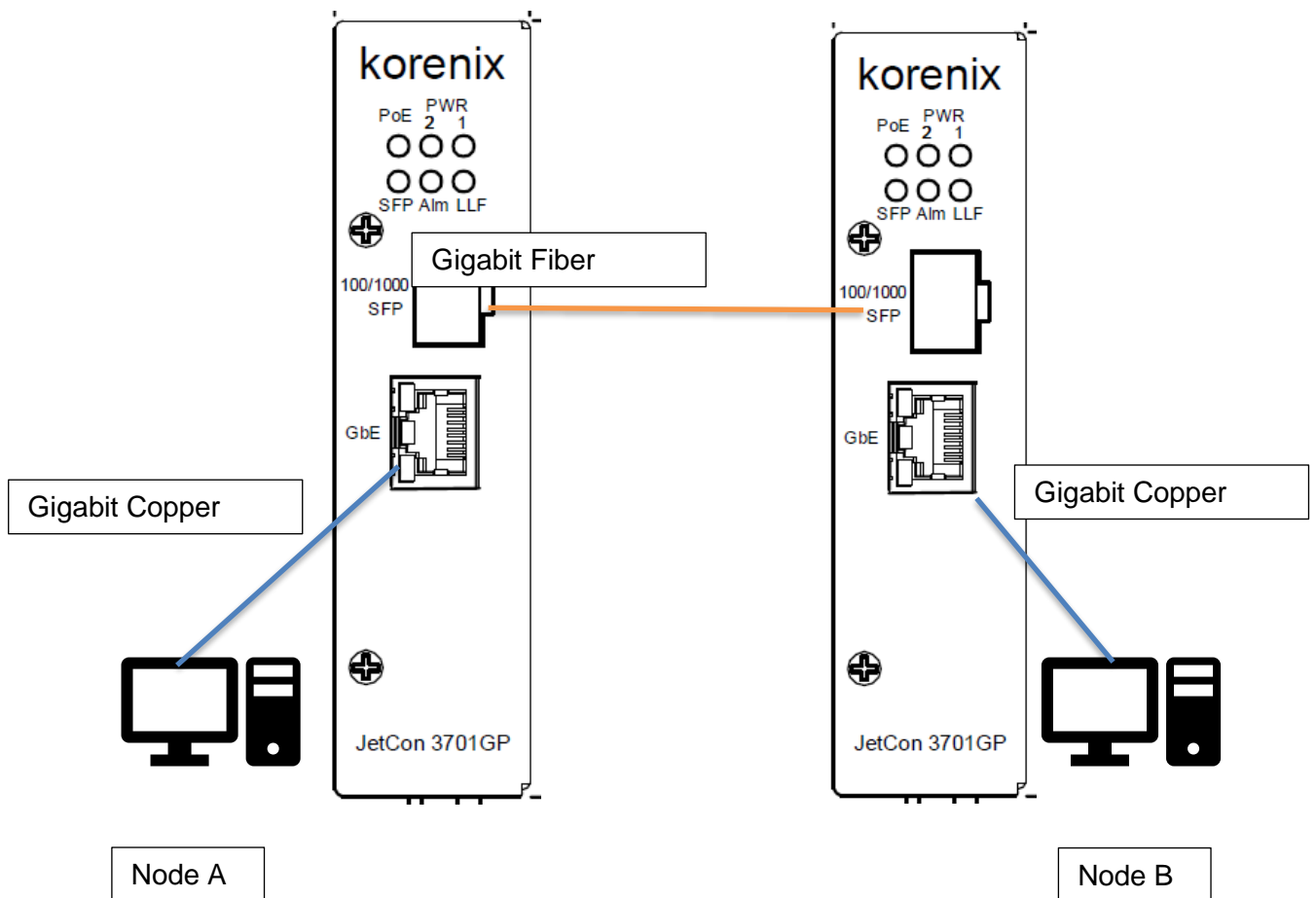

In the above diagram includes node A, B and converter A,B. Both of converters linked with Gigabit fiber. In traditional fiber network architecture; if the Gigabit copper of node A link down, the node B will not have any information, just packet can't forward between A and B.

With the Link Loss Forwarding feature, the link down event of node A will forward to converter A and B. Therefore, converter A will turn off the fiber signal and converter B will turn off Gigabit copper signal to inform node B that port link down event occurred until the node A port recovery. In some application, you also can obtain an event alarm signal by enable the port event alarm function. Please refer to the section 4-4.

The following procedures will introduce how to configure LLF function.

Step 1: power on the device A, B and connect the fiber and copper ports.

Step 2: Ensure the port link LEDs is working exactly.

Step 3: if the port link event occurred, the other port will be trigger and turn off by the LLF mechanism.

Step 4: To start the transmission and retrieve the L.L.F. function, the LLF Dipswitch should be reset again.

4-4. Event Alarm Relay Configuration

The connection of Event Alarm Relay already described in section **2-5 Connect the Dry Relay output** and this section will introduce how to enable it

5. System Installation

5-1. Installation and Testing

1. Take out your JetCon 3701GP-U Industrial Gigabit Media Converter from the package box.
2. Check if the DIN-Rail clip is attached to the JetCon 3701GP-U. If the DIN-Rail clip is not attached to the JetCon 3701GP-U, refer to **DIN-Rail Mounting** section for DIN-Rail installation.
3. To place the JetCon 3701GP-U on the DIN-Rail track or wall, refer to the **Mounting Installation** section.
4. Pull the terminal blocks off the JetCon 3701GP-U and wire the power lines. Refer to the **Wiring the DC Power Inputs** section for how to wire the power inputs.
5. PWR1 and PWR2 dual power inputs can be connected to power sources simultaneously. When the primary power source fails (the default setting is PWR1), the system will automatically switch to the secondary power source (PWR2), preventing any power interruption.
Both of Power 1 and Power 2 support positive electricity power system. Please notice the power system for power 1 and power 2 only accept positive electricity power system at one time
6. Check the LEDs of PWR1 and PWR2 to make sure that JetCon 3710GP-U is operating normally.
7. Use Category 5e straight through Ethernet cables with RJ-45 connectors to connect network devices.
8. Connect one side of an Ethernet cable with a RJ-45 connector to the JetCon 3701GP-U's Ethernet port (RJ-45 port), and the other side of the fiber cable to the network device's Gigabit fiber port.

If you want to connect with Gigabit Fiber, please install appropriate SFP fiber transceiver and fiber cable. To ensure the connection is working, please notice the type of fiber transceiver of JetCon 3701GP-U's and the other end of device.

9. Check the LED indicator of port status (blinking green) on the JetCon 3701GP-U to see if the network connection is successfully established. Power on the PC host, activate the Command Line mode, and ping the connected Ethernet device to see if it responds.

9.1 To enable the "Command Line mode", click **Run** in the Start menu, type **Command**, and click **OK** to continue.

10.

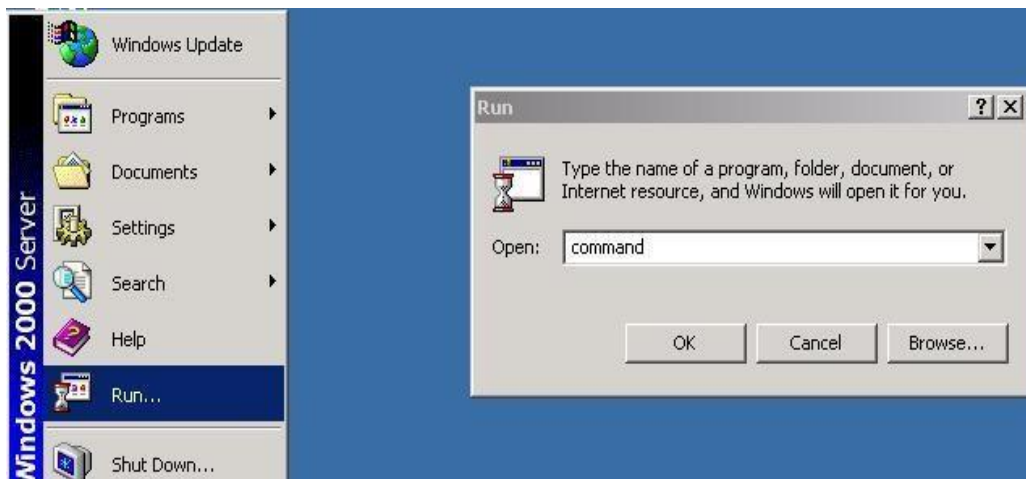

connected to power sources. When PWR1 fails, the LED for PWR1 will go out. At that moment, if the ping command is still replying, then it proves that redundant power input function works normally.

13. Exit the Command Line mode, and connect PWR1 power input. At this stage, your JetCon 3701GP-U has been tested and the installation is completed.

6. Troubles shooting

- Make sure you are using the correct DC power suppliers (DC44~57 V) or power adapters.
- Select Ethernet cables with specifications suitable for your applications to set up your systems. Ethernet cables are categorized into unshielded twisted-pair (UTP) and shielded twisted-pair (STP) cables. Category 3, 4, 5 Ethernet cables are suitable for systems with 10 Mbps transmission speed. For systems with 100/1000 Mbps transmission speed, Category 5, 5e, 6 Ethernet cables are the suitable specifications for this environment. Also make sure that the distance between each node cannot be longer than 100 meters (328 feet).
- If the power LEDs goes off as the power cord plugged in, a power failure might occur. Check the power output connection to see if there is any error at the power source. If you still cannot solve the problem, contact your local dealer for assistance

7. Technical Specifications

Technology																												
Standard	IEEE802.3 10Base-T IEEE802.3u 100BaseTX/FX IEEE802.3ab 1000Base-T IEEE802.3z Gigabit Ethernet Fiber IEEE802.3x flow control and back-pressure IEEE802.1p Class of Service IEEE802.1Q Quality of Service IEEE 802.3af Power Over Ethernet IEEE 802.3at High Power PoE+ IEEE 802.3bt(draft 2.0) High Power PoE++																											
Performance																												
Forwarding Technology	Store and Forward technology with 64- 10K bytes packet forwarding ability																											
System Throughput	1.49 Mpps																											
Packet buffer	1 Mbits																											
MAC Address	8k																											
Link Loss Forwarding	Two-way loss-signature auto forwarding																											
Event Alarm	relay alarm output for power events																											
Class of Service	Compliance with IEEE802.1p with WRR 8:4:2:1 for 4 queues - Highest/High/Low/Lowest. Packets are classified as Highest(6,7), High(4,5), Low(0,3), Lowest(1,2), default Low(0).																											
Quality of Service	Supports IPv4/IPv6 packet priority, DSCP and ToS. DSCP/ToS tag is prior to CoS tag if both exist in a frame. Queue Mapping Table: <table border="1" data-bbox="785 1102 1289 1440"> <thead> <tr> <th>DSCP Value</th> <th>Forwarding Queue</th> <th>ToS Value</th> </tr> </thead> <tbody> <tr> <td>0-7</td> <td>Low</td> <td>0</td> </tr> <tr> <td>8-15</td> <td>Lowest</td> <td>1</td> </tr> <tr> <td>16-23</td> <td>Lowest</td> <td>2</td> </tr> <tr> <td>24-31</td> <td>Low</td> <td>3</td> </tr> <tr> <td>32-39</td> <td>High</td> <td>4</td> </tr> <tr> <td>40-47</td> <td>High</td> <td>5</td> </tr> <tr> <td>48-55</td> <td>Highest</td> <td>6</td> </tr> <tr> <td>56-63</td> <td>Highest</td> <td>7</td> </tr> </tbody> </table>	DSCP Value	Forwarding Queue	ToS Value	0-7	Low	0	8-15	Lowest	1	16-23	Lowest	2	24-31	Low	3	32-39	High	4	40-47	High	5	48-55	Highest	6	56-63	Highest	7
DSCP Value	Forwarding Queue	ToS Value																										
0-7	Low	0																										
8-15	Lowest	1																										
16-23	Lowest	2																										
24-31	Low	3																										
32-39	High	4																										
40-47	High	5																										
48-55	Highest	6																										
56-63	Highest	7																										
Broadcast filtering	Default enabled Traffic threshold: 25Mbps @ 1000Mbps; 10Mbps @ 100Mbps; 1Mbps @ 10 Mbps																											
PoE forwarding conductor	RJ-45: V-(1,2,7,8), V+ (3,6,4,5)																											
PoE forwarding capability	PoE Port: 15W/IEEE802.3af, 30W/IEEE 802.3at. 60W/IEEE802.3bt,90W/IEEE802.3bt PoE System Power Budget: 90W at 75°C Ambient temperature																											
Interface																												
Enclosure Port	1 x 100/1000 Base-TX with Auto MDI/MDI-X function, Auto-Negotiation 1 x SFP socket with hot-swappable function for 100/1000 Ethernet SFP Transceiver																											
Alarm Contact	1 relay output with current carrying capacity of 1 A @ 24 VDC Terminal block: 4-Pin for redundant power input; 2-Pin for alarm relay output.																											
Cables	RJ-45 Connector: 4 pairs of Cat-5e UTP/STP cable Arrangement for 1000Base-T. Maximum link distance is 100meters.																											

Diagnostic LEDs	System: <ul style="list-style-type: none"> - 2 x Power (Green): On (Power On), Off (Power Off) - 1 x Link Loss Forwarding (Red): On (Link Loss), Off (Data Transfer) - 1 x Alarm (Red): On (Disconnect), Off (Connected) - 1 x Power over Ethernet (Green): On (PD Detect), Off (None-Detect) Ethernet port: - Link/Activity (Green): On (Link), Blinking (Activity) - Speed (Amber): On (Speed 1000), Off (Speed 10/100) SFP port: - Link/Activity (Green): On (Link), Fast Blinking (Speed 1000), Slow Blinking (Speed 100)
Power Connector	Removable Terminal Block: 44-57V power Input
Link Loss Forwarding	Default Enable
Power Requirement	
Power	Removable Terminal Block: 44-57V power Input IEEE 802.3bt 90W PoE application: DC 52-57V IEEE 802.3bt 60W PoE application: DC 52-57V IEEE 802.3at 30W PoE application: DC 50-57V IEEE 802.3af 15.4W PoE application: DC 44-57V Power input with polarity reverse correction and over current protection.
Power Consumption	3Watts/ DC 48V (without PoE loading)
Mechanical	
Enclosure Protection	Ingress Protection code - 31
Case	Slim metal case
Mounting	DIN Rail
Dimension	99(D) x30(W)x 120(H) mm (Without Din-rail kit)
Weight	0.6kg with package 0.9kg without package
Environmental	
Operating Temperature	-40°C-75°C
Operating Humidity	0% ~ 95% non-condensing
Storage Temperature	-40°C-80°C
Storage Humidity	0%- 95% non-condensing
Approvals	
EMI	CE/EN 55032 class A, FCC Class A, EN 61000-3-2 :2014, EN 61000-3-3, EN 61000-6-4, EN50121-4 (Compliance)
EMS	CE/ EN 55024, EN 61000-6-2, IEC 61000-4-2,IEC 61000-4-3, IEC 61000-4-4, IEC 61000-4-5, IEC 61000-4-6, IEC 61000-4-8, IEC 61000-4-11
Shock	IEC60068-2-27 (Compliance)
Vibration	IEC60068-2-6 (Compliance)
Free Fall	IEC60068-2-32 (Compliance)
Warranty	5 years
Ordering Information	
JetCon 3701GP-U	Industrial Gigabit PoE Ethernet Media Converter
Includes	1x JetCon 3701GP-U Industrial Gigabit PoE Ethernet Media Converter 1x Quick Installation Guide
Optional Accessories	

Fiber Transceiver

- Gigabit Multi-Mode SFP Transceiver
- Gigabit Single-Mode SFP Transceiver
- Gigabit BIDI/WDM Single-Mode SFP Transceiver
- 100Base Multi-Mode SFP Transceiver
- 100Base Single-Mode SFP Transceiver
- 100Base BIDI/WDM Single-Mode SFP Transceiver

8. SFP Fiber Transceiver Order Information

Part Number	Description
SFPGSX	Gigabit SX SFP Transceiver, 850nm, multi-mode/LC, 550m
SFPGSX-w	Gigabit SX SFPTransceiver, 850nm, multi-mode/LC,550m, -40~85°C Wide Temp.
SFPGSX2	Gigabit SX SFP Transceiver, 850nm, multi-mode/LC, 2km
SFPGSX2-w	Gigabit SX SFP Transceiver, 850nm, multi-mode/LC, 2km, -40~85°C Wide Temp.

Revision History

Edition	Date	Modifications
V1.0	05-Jun,2019	New edition