



USER GUIDE

60 GHz cnWave™

System Release 1.1



Accuracy

While reasonable efforts have been made to assure the accuracy of this document, Cambium Networks assumes no liability resulting from any inaccuracies or omissions in this document, or from use of the information obtained herein. Cambium reserves the right to make changes to any products described herein to improve reliability, function, or design, and reserves the right to revise this document and to make changes from time to time in content hereof with no obligation to notify any person of revisions or changes. Cambium does not assume any liability arising out of the application or use of any product, software, or circuit described herein; neither does it convey license under its patent rights or the rights of others. It is possible that this publication may contain references to, or information about Cambium products (machines and programs), programming, or services that are not announced in your country. Such references or information must not be construed to mean that Cambium intends to announce such Cambium products, programming, or services in your country.

Copyrights

This document, Cambium products, and 3rd Party software products described in this document may include or describe copyrighted Cambium and other 3rd Party supplied computer programs stored in semiconductor memories or other media. Laws in the United States and other countries preserve for Cambium, its licensors, and other 3rd Party supplied software certain exclusive rights for copyrighted material, including the exclusive right to copy, reproduce in any form, distribute and make derivative works of the copyrighted material. Accordingly, any copyrighted material of Cambium, its licensors, or the 3rd Party software supplied material contained in the Cambium products described in this document may not be copied, reproduced, reverse engineered, distributed, merged or modified in any manner without the express written permission of Cambium. Furthermore, the purchase of Cambium products shall not be deemed to grant either directly or by implication, estoppel, or otherwise, any license under the copyrights, patents or patent applications of Cambium or other 3rd Party supplied software, except for the normal non-exclusive, royalty free license to use that arises by operation of law in the sale of a product.

Restrictions

Software and documentation are copyrighted materials. Making unauthorized copies is prohibited by law. No part of the software or documentation may be reproduced, transmitted, transcribed, stored in a retrieval system, or translated into any language or computer language, in any form or by any means, without prior written permission of Cambium.

License Agreements

The software described in this document is the property of Cambium and its licensors. It is furnished by express license agreement only and may be used only in accordance with the terms of such an agreement.

High Risk Materials

Cambium and its supplier(s) specifically disclaim any express or implied warranty of fitness for any high-risk activities or uses of its products including, but not limited to, the operation of nuclear facilities, aircraft navigation or aircraft communication systems, air traffic control, life support, or weapons systems (“High Risk Use”).

This product is not restricted in the EU. Any High Risk is unauthorized, is made at your own risk and you shall be responsible for any and all losses, damage or claims arising out of any High-Risk Use.

Contents

Contents	3
Chapter 1: About This User Guide	10
Purpose	10
Cross-references	10
Feedback	10
Important regulatory information	10
Complying with rules for the country of operation	10
Application Firmware	12
Ethernet networking skills	12
Lightning protection	12
Specific expertise and training for professional installers	12
Legal and Open Source Software statements	12
Problems and warranty	12
Reporting problems	12
Repair and service	13
Hardware warranty	13
Security advice	13
Warnings, cautions, and notes	13
Caring for the environment	14
In EU countries	14
In non-EU countries	14
Chapter 2: Product Description	15
Purpose	15
Introduction to 60 GHz	15
Understanding of 60 GHz	15
Frequency bands	15
Characteristics of 60 GHz	16
Introduction to 802.11ay and advantages	18

Terragraph	19
cnWave family overview	20
Features	21
Wireless operation	22
Wireless topology	22
Modulation	24
Synchronization	25
Time division duplexing access mechanism	26
Wireless encryption	27
Designing wireless networks	27
TDD synchronization	27
System management	27
Management agent	27
Network management	28
IPv6	28
System logging	28
Software upgrade	28
Chapter 3: System Hardware	29
Wireless nodes	29
V1000 Client Node	29
V3000 Client Node (CN)	30
V5000 Distribution Node (DN)	30
Radio mounting brackets	31
Radio accessories	35
Radio external interfaces	36
Radio specifications	39
Theory of operation	40
Power supply units (PSU)	41
PSU options	41
V1000 power over Ethernet	42

V3000, V5000 Power over Ethernet	43
PSU specifications	47
Ethernet and DC cables	47
Maximum cable lengths	47
Outdoor copper CAT6A Ethernet cable	49
Cable accessories	50
SFP module kits	50
Optical cable and connectors	51
Chapter 4: System Planning	53
Site planning	53
Grounding and lightning protection	53
Lightning protection zones	53
Site grounding system	54
ODU location	54
Drop cable grounding points	55
ODU wind loading	55
PSU DC power supply	56
PSU AC power supply	56
PSU location	56
Outdoor AC/DC PSU	57
Lightning Surge Protection Units (LPU)	57
Drop cable grounding points	57
Lightning Surge Protection Units location	58
Network Design Consideration	58
Golay Code assignment	58
Angle separation	59
Avoid butterfly pattern	59
Near-Far ratio	60
Y-Street avoidance	60
Radio spectrum planning	61

General wireless specifications	61
Regulatory limits	62
Link planning	62
LINKPlanner	62
Range and obstacles	63
Path loss	63
Data network planning	64
Point to Point based single link Ethernet bridge	64
IPv4/L2 based PMP and mesh network planning	64
Mixture of IPv4 and IPv6 support	66
IPv6 mode network planning	66
IPv6 network design consideration	67
Reserved IPv6 address space	67
E2E and cnMaestro deployment consideration	68
Ethernet bridging/IP routing	68
Multi-PoP deployments	69
Layer two control protocols	70
Ethernet port allocation	70
IP interface	70
Daisy-chaining 60 GHz links	70
Chapter 5: Installation	72
Safety	72
Power lines	72
Working at heights	72
PSU	72
Grounding and protective earth	72
AC supply	72
Powering down before servicing	73
Primary disconnect device	73
External cables	73

Drop cable tester	73
RF exposure near the antenna	73
Minimum separation distances	73
Grounding and lightning protection requirements	73
Grounding cable installation methods	73
Siting radios	74
60 GHz cnWave™ radios and mounting bracket options	74
Mounting bracket options	74
Installing the cnWave radio nodes	74
ODU interface with LPU on the poll	78
Attach ground cables to the radio	81
Mounting the ODU on the mast or wall	81
Connect to the PSU port of the radio	96
Using power over Ethernet (PoE)	96
Using AC/DC PSU	98
Install the PSU	99
Installing the 60W DC power injector	100
Installing the AC/DC PSU	101
Installing the V1000 power injector	101
Connecting to the SFP+ optical module or SFP+ to copper module to ODU	102
Removing the cable and SFP module	107
Chapter 6: Configuring 60 GHz cnWave™	109
Nodes deployment	109
Connecting to the unit	109
Configuring the management PC	110
Connecting to the PC and powering up	111
Using the web interface	111
Logging into the web interface	111
Enabling internal E2E Controller	117
Topology	120

Configuration	124
Chapter 7: Operation	147
Software upgrade	147
Events	151
Statistics	152
Links	152
Ethernet	153
GPS	154
Radio	155
Performance	156
Prefix Zone Statistics	160
Engineering	161
Border Gateway Protocol (BGP)	161
Maps	162
Tools	162
cnMaestro support for Onboard Controller	164
Chapter 8: Regulatory Information	168
Compliance with safety standards	168
Electrical safety compliance	168
Human exposure to radio frequency energy	169
Compliance with radio regulations	171
Type approvals	172
FCC compliance	172
ISED compliance	172
60 GHz cnWave™ example product labels	173
Chapter 9: Troubleshooting	175
Field diagnostics logs	175
Setup issues in IPv4 tunneling	176
Link is not established	180
PoP not online from E2E/cnMaestro GUI	183

Link is not coming up	183
Link does not come up after some configuration change	183
Link is not having expected throughput performance	183
Factory reset	184
Cambium Networks	185

Chapter 1: About This User Guide

This document explains how to deploy the 60 GHz products along with important safety measures. It is intended for use by the system designer, system installer and system administrator.

Purpose

Cambium Networks 60 GHz products documents are intended to instruct and assist personnel in the operation, installation, and maintenance of the equipment and ancillary devices. It is recommended that all personnel engaged in such activities be properly trained.

Cambium Networks disclaims all liability whatsoever, implied or express, for any risk of damage, loss or reduction in system performance arising directly or indirectly out of the failure of the customer, or anyone acting on the customer's behalf, to abide by the instructions, system parameters, or recommendations made in this document.

Cross-references

References to external publications are shown in italics. Other cross-references, emphasized in blue text in electronic versions, are active links to the references.

This document is divided into numbered chapters that are divided into sections. Sections are not numbered but are individually named at the top of each page, and are listed in the table of contents.

Feedback

We appreciate feedback from the users of our documents. This includes feedback on the structure, content, accuracy, or completeness of our documents. To provide feedback, visit our support website: <https://support.cambiumnetworks.com>.

Important regulatory information

Complying with rules for the country of operation

USA specific information



Caution

This device complies with Part 15 of the FCC Rules. Operation is subject to the following two conditions:

- This device may not cause harmful interference, and
- This device must accept any interference received, including interference that may cause undesired operation.



Note

This equipment has been tested and found to comply with the limits for a Class B digital device, pursuant to part 15 of the FCC Rules. These limits are designed to provide reasonable protection against harmful interference in a residential installation. This equipment generates, uses and can radiate radio frequency energy and, if not installed and used in accordance with the instructions, may cause harmful interference to radio communications. However, there is no guarantee that interference will not occur in a particular installation. If this equipment does cause harmful interference to radio or television reception, which can be determined by turning the equipment off and on, the user is encouraged to try to correct the interference by one or more of the following measures:

- Reorient or relocate the receiving antenna.
- Increase the separation between the equipment and receiver.
- Connect the equipment into an outlet on a circuit different from that to which the receiver is connected.
- Consult the dealer or an experienced radio/TV technician for help.

Canada specific information



Caution

This device complies with ISED's license-exempt RSSs. Operation is subject to the following two conditions:

- This device may not cause interference; and
- This device must accept any interference, including interference that may cause undesired operation of the device.

Renseignements spécifiques au Canada



Attention

Le présent appareil est conforme aux CNR d'Industrie Canada applicables aux appareils radio exempts de licence. L'exploitation est autorisée aux deux conditions suivantes :

- l'appareil ne doit pas produire de brouillage, et
- l'utilisateur de l'appareil doit accepter tout brouillage radioélectrique subi, même si le brouillage est susceptible d'en compromettre le fonctionnement.

European specific information

Cambium Networks 60 GHz cnWave™ products are compliant with applicable European Directives required for CE marking:

- 2014/53/EU of the European Parliament and of the Council of 16 April 2014 on the harmonisation of the laws of the Member States relating to the making available on the market of radio equipment and repealing Directive 1999/5/EC; Radio Equipment Directive (RED)

- 2011/65/EU of the European Parliament and of the Council of 8 June 2011 on the restriction of the use of certain hazardous substances in electrical and electronic equipment (RoHS Directive).

The 59-63.9 GHz frequency band is subject to specific exclusion zones. For more information, see [59 - 63.9 GHz transmission exclusion zones](#) table.

EU Declaration of Conformity

Hereby, Cambium Networks declares that the Cambium Networks 60 GHz cnWave™ Series of Wireless Ethernet Bridge complies with the essential requirements and other relevant provisions of Directive 2014/53/EU. The declaration of conformity may be consulted at: https://www.cambiumnetworks.com/eu_dofc.

Application Firmware

Download the latest 60GHz products family software and install it in the Outdoor Units (ODUs) before deploying the equipment. Instructions for installing software are provided in this guide.

Ethernet networking skills

The installer must have the ability to configure IP addressing on a PC and to set up and control products using a web browser interface.

Lightning protection

To protect outdoor radio installations from the impact of lightning strikes, the installer must be familiar with the normal procedures for site selection, bonding and grounding. Installation guidelines for the 60 GHz cnWave™ Family can be found in [Chapter 3: System hardware](#) and [Chapter 4: System planning](#).

Specific expertise and training for professional installers

To ensure that the 60 GHz cnWave™ Series are installed and configured in compliance with the requirements of the EU, ISEDC and the FCC, installers must have the radio engineering skills and training described in this section.

The Cambium Networks technical training program details can be accessed from below link: <https://www.cambiumnetworks.com/training/>

Legal and Open Source Software statements

Refer to the *60 GHz cnWave™ Legal and Open Source Guide* for:

- Cambium Networks end user license agreement
- Open Source Software Notices

Problems and warranty

Reporting problems

If any problems are encountered when installing or operating this equipment, follow this procedure to investigate and report:

1. Search this document and the software release notes of supported releases.
2. Visit the support website (<http://www.cambiumnetworks.com/support>).

3. Ask for assistance from the Cambium product supplier.
4. Gather information from affected units, such as any available diagnostic downloads.
5. Escalate the problem by emailing or telephoning support.

Repair and service

If unit failure is suspected, obtain details of the Return Material Authorization (RMA) process from the support website (<http://www.cambiumnetworks.com/support>).

Hardware warranty

Cambium's standard hardware warranty is for one (1) year from date of shipment from Cambium Networks or a Cambium distributor. Cambium Networks warrants that hardware will conform to the relevant published specifications and will be free from material defects in material and workmanship under normal use and service. Cambium shall within this time, at its own option, either repair or replace the defective product within thirty (30) days of receipt of the defective product. Repaired or replaced product will be subject to the original warranty period but not less than thirty (30) days.

To register positioner products or activate warranties, visit the support website. For warranty assistance, contact the reseller or distributor. The removal of the tamper-evident seal will void the warranty.



Caution

Using non-Cambium parts for repair could damage the equipment or void warranty. Contact Cambium for service and repair instructions.

Portions of Cambium equipment may be damaged from exposure to electrostatic discharge. Use precautions to prevent damage.

Security advice

Cambium Networks systems and equipment provide security parameters that can be configured by the operator based on their particular operating environment. Cambium recommends setting and using these parameters following industry recognized security practices. Security aspects to be considered are protecting the confidentiality, integrity, and availability of information and assets. Assets include the ability to communicate, information about the nature of the communications, and information about the parties involved.

In certain instances, Cambium makes specific recommendations regarding security practices, however the implementation of these recommendations and final responsibility for the security of the system lies with the operator of the system.

Warnings, cautions, and notes

The following describes how warnings and cautions are used in this document and all Cambium Networks document sets:

Warnings

Warnings precede instructions that contain potentially hazardous situations. Warnings are used to alert the reader to possible hazards that could cause loss of life or physical injury. A warning has the following format:



Warning

Warning text and consequence for not following the instructions in the warning.

Cautions

Cautions precede instructions and are used when there is a possibility of damage to systems, software, or individual items of equipment within a system. However, this damage presents no danger to personnel. A caution has the following format:



Caution

Caution text and consequence for not following the instructions in the caution.

Notes

A note means that there is a possibility of an undesirable situation or provides additional information to help the reader understand a topic or concept. A note has the following format:



Note

Note text.

Caring for the environment

The following information describes national or regional requirements for the disposal of Cambium Networks supplied equipment and for the approved disposal of surplus packaging.

In EU countries

The following information is provided to enable regulatory compliance with the European Union (EU) directives identified and any amendments made to these directives when using Cambium equipment in EU countries.

Disposal of Cambium equipment

European Union (EU) Directive 2012/19/EU Waste Electrical and Electronic Equipment (WEEE).

Do not dispose of Cambium equipment in landfill sites. For disposal instructions, refer to <http://www.cambiumnetworks.com/support/weee-compliance>

Disposal of surplus packaging

Do not dispose of surplus packaging in landfill sites. In the EU, it is the individual recipient's responsibility to ensure that packaging materials are collected and recycled according to the requirements of EU environmental law.

In non-EU countries

In non-EU countries, dispose of Cambium equipment and all surplus packaging in accordance with national and regional regulations.

Chapter 2: Product Description

Purpose

Cambium Networks 60 GHz cnWave™ solution provides easy, fast and cost-effective wireless Gigabit connectivity for edge access and/or high-capacity backhaul for edge access solutions at a significantly lower cost than fiber infrastructure. Service providers and enterprises now have access to Gigabit for business and residential connectivity, backhaul for Wi-Fi access. Certified for Facebook Terragraph, 60 GHz cnWave™ Mesh solutions are highly efficient at handling high-density deployments in cities and suburban areas.

Introduction to 60 GHz

The 60 GHz cnWave portfolio boasts a wide spectrum of up to 9 GHz (57-66 GHz) that is typically divided into channels of roughly 2 GHz each. The 60 GHz band is largely uncongested compared to the 2.5 GHz and 5 GHz public bands currently used for Wi-Fi. The 60 GHz band is an unlicensed millimeter wave band that can provide massive speeds and throughput with Line of Sight (LoS) applications.

Understanding of 60 GHz

The 60 GHz band is located in the millimeter-wave (30 GHz to 300 GHz) portion of the electromagnetic spectrum.

The millimeter-wave portion of the RF spectrum has been largely unexploited for commercial wireless applications. 60 GHz Wireless has used its well-established expertise in millimeter-wave products and technologies to develop wireless products operating in that spectrum that enable two-way wireless communications at data rates that previously could only be accomplished with fiber optic cable.

In addition to the high-data rates that can be accomplished in this spectrum, energy propagation in the 60 GHz band has unique characteristics that make possible many other benefits such as excellent immunity to interference, high security, and frequency re-use.

Frequency bands

It is proposed that the 60 GHz band is divided into 11 channels each with bandwidth of 2.16 GHz starting from **57.24** to **70.2 GHz**. Channel 1 to 6 has 2.16 GHz bandwidth and are defined in 802.11ad, channel 9 to 13 has 4.32 GHz bandwidth and are added in 802.11ay.

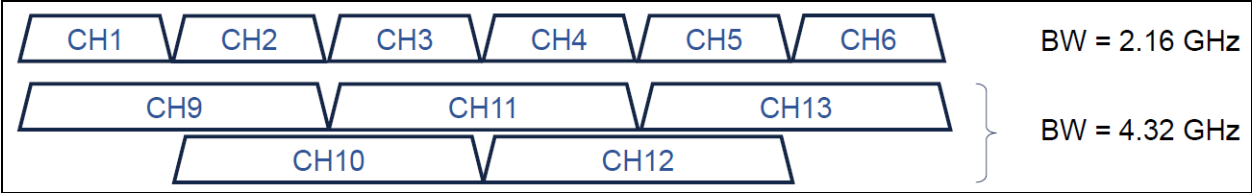

Figure 1: Frequency bands

The following table describes the channels and corresponding bandwidths supported by 60 GHz cnWave™:

Table 1: Channels and corresponding bandwidths supported by 60 GHz cnWave™

Channel	Bandwidth (GHz)	Center (GHz)	Min. (GHz)	Max. (GHz)
1	2.16	58.32	57.24	59.40
2	2.16	60.48	59.40	61.56
3	2.16	62.64	61.56	63.72
4	2.16	64.80	63.72	65.88

Characteristics of 60 GHz

The following are the important characteristics of 60 GHz cnWave™ :

- **High Throughput capability**

With multi-gigabit channel bandwidth, it is possible to gain multi-gigabit capacity, based on 802.11ad it is possible to get 5 Gbps PHY rate and with 802.11ay it is possible to get 10 Gbps PHY rate. cnWave products are capable to providing 15 Gbps Ethernet rates with channel bonding enabled.

- **Unlicensed and interference free**

Typically, V Band is either unlicensed or lightly licensed band and since this band is relatively newly opening there will often be limited interference compared to 2.4 and 5 GHz bands.

- **Line of Sight**

60 GHz is affected by oxygen absorption, it varies throughout the band. The absorption gets reduced if the frequency gets increased. For example, the absorption is 15 dB/km in 60 GHz frequency, 5 dB/km in 64 GHz and 0.5 dB/km in 68 GHz. If the total channel is divided into 6 channels, then the mid channel that is channels 2 and 3 has more absorption loss. From channel 4, the absorption level starts to drop. So only Line of Sight links are available and Near LoS or non LoS does not work with 60 GHz.

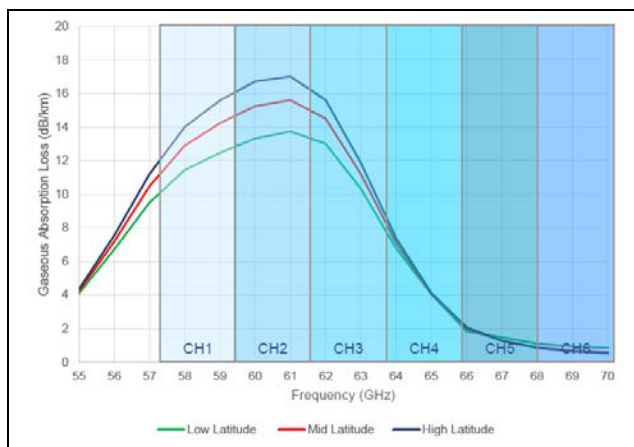

Figure 2: Line of Sight

- **Rain fade**

The user can expect to see significant rain fade for 60 GHz links, particularly those pushing the longer distances. Attenuation depends on the rain rate which must be factored in while planning the network. Rain attenuation depends on the level of the rain. The following table describes the rain level and absorption loss:

Table 2: Rain and attenuation

Rain	Attenuation
Drizzle (0.25 mm/hr)	0.2 dB/km
Light Rain (2.5 mm/hr)	1.8 dB/km
Medium Rain (12.5 mm/hr)	5.6 dB/km
Heavy Rain (25 mm/hr)	9.5 dB/km
Downpour (50 mm/hr)	17 dB/km
Tropical (100 mm/hr)	28 dB/km
Monsoon (200 mm/hr)	38 dB/km

The following figure shows the absorption loss due to the rain level (seasons):

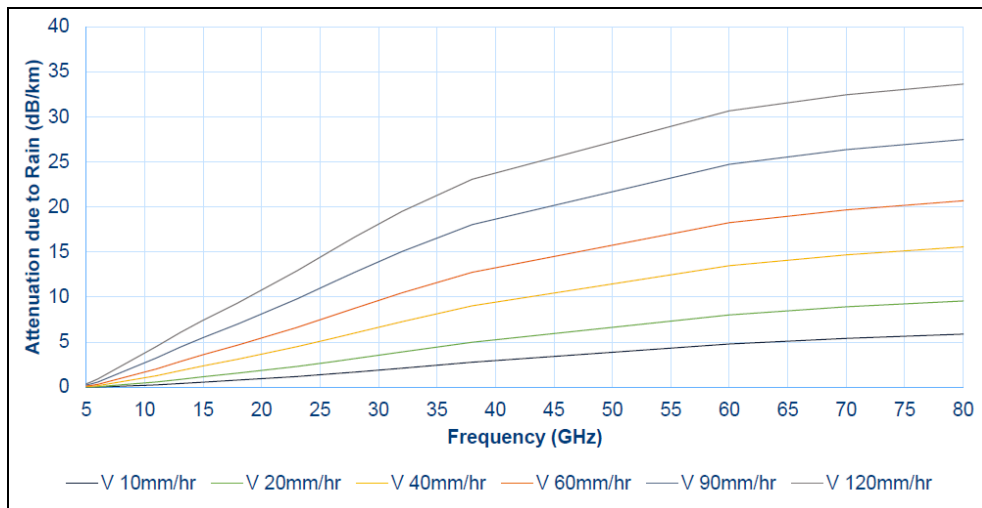

Figure 3: Variation in Loss/km with frequency and rain rate

Drizzle - 0.25 mm/hr; Light rain - 2.5 mm/hr; Medium rain - 12.5 mm/hr; Heavy rain - 25 mm/hr.

- **Short range**

The range of a 60 GHz cnWave™ link can be limited due to oxygen absorption and rain fade which needs to be factored in for link planning. One advantage of shorter range is frequency re-usability and security (since the signal does not travel long distances).

Introduction to 802.11ay and advantages

- **802.11ay product, Terragraph certified**

The 60 GHz cnWave™ is 802.11ay product and Terragraph certified.

- **Highest capacity**

It has highest capacity in industry, upto 7.2 Gbps per sector.

- **Low total cost ownership**

- cnWave V5000 is 280 degree coverage with dual sector. Installation is simple, uses beam forming for installation. No need for site router.
- cnWave V1000 and cnWave V3000 meets various range challenges.
- Using beam forming V3000 has super long range.
- cnMaestro panel is used for device management.
- cnHeat and LINKPlanner helps for easy planning.

- **Unlicensed and interference free**

This spectrum spans 57 - 66 GHz and is widely available, especially when compared to the 2.4 and 5 GHz bands. This 9 GHz of spectrum can be divided up into channels ranging between 1 and 2 GHz wide.

- **Massive throughput**

This band can allow for up to 15 Gbps of throughput from some products on the market today.

Introduction to 802.11ay and advantages

IEEE 802.11ay is IEEE standard which covers 60 GHz cnWave™, this is standard is an amendment of the IEEE 802.11ad standard. There are IEEE 802.11ay is designed with a higher throughput capacity of over 10 Gbps data rate over distances of 200 to 500 meters. 802.11ay includes features such as Channel Bonding and Synchronization. 802.11ay based 60 GHz solution really transforms fixed wireless access from a broadband option of last resort into a competitive alternative to fiber and cable-based solution.

This standard is designed with a throughput capacity of over 10 Gbps data rate over distances of 200 to 500 meters. 802.11ay includes features such as **Channel Bonding** and **Synchronization**. 802.11ay is WLAN type in the IEEE 802.11. It has frequency of 60 GHz. It has also been noted that it is likely to have mechanisms for channel bonding and MU-MIMO technologies. 802.11ad uses a maximum of 2.16 GHz bandwidth, whereas 802.11ay bonds four of those channels together for a maximum bandwidth of 8.64 GHz.

802.11ay standard has following advantages with Terragraph solution:

- **Channel Bonding**

802.11ay standard has channel bonding capability to combines adjacent channels to form wider channels, in this case wider channel combine to form 4.32 GHz, there are additional wider channels created which provide double capacity throughput compared to 802.11ad standard.

- **Network Synchronization**

Synchronization is used to control the transmit and receive signals to prevent self-interference. Radios assigned with the same polarity will be transmitting and receiving at the same time.

There are four types of polarity:

- Odd Polarity
- Even Polarity
- Hybrid odd Polarity
- Hybrid Even Polarity

- **Mesh Routing**

Mesh is interconnection among devices which could have multiple paths between any two nodes, some advantages of using mesh are better connectivity, capacity sharing, Load balancing and re-routing in case of link failure.

- **Increase in capacity**

802.11ay supports Channel Bonding which allows two immediate channels to be merged into a single wide-band channel, thereby doubling the channel bandwidth to 4.32 GHz.

- **Supports more number of client nodes**

802.11ay supports 15 client nodes per sector.

Terragraph

Terragraph is a connectivity solution from Facebook. The mission of Terragraph is bringing more people online to a faster internet. It is freely licensed technology designed to deliver cost-effective, reliable, fiber-like connectivity over a wireless mesh network.

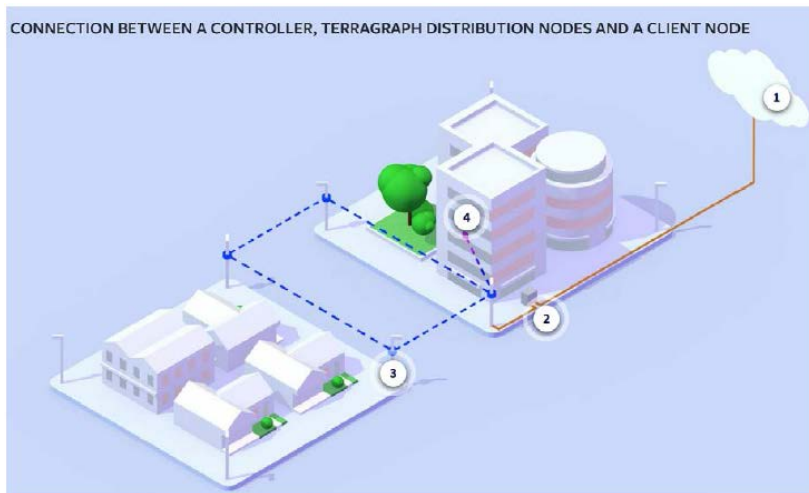

- 1- Controller
- 2- PoP (Fiber, RF etc)
- 3- Distribution Node
- 4- Client Node

Key components

Terragraph contains the following key components:

- **Distribution Node (DN)** - DN connect with other DN to form a mesh in distribution network.
- **Client Node (CN)** - CN is a customer premise radio that connects with a DN node to provide high speed connectivity.
- **E2E Controller** - The E2E Controller allows for configuration, control and monitoring of the nodes and network. Cambium Networks supports two methods to utilize the E2E Controller:
 - On-Premises installed as a VM and can be used for small or large deployment.
 - Onboard the PoP, for PTP, PMP, and small mesh networks the PoP can be configured to host the controller (limited to 21 nodes).

Features

The following are the features of Terragraph:

- **802.11ay** - Delivers multi-gigabit speeds over wide frequency bands
- **Mesh** - Efficiently distributes capacity and improves availability, using Open/R
- **Efficient MAC and PHY** - Scheduled MAC (TDD / TDMA) for scalability and dense deployments
- **Cloud management** - Used for configuration, management, visualization, alarms, and monitoring
- **Network planning** - Automated design and optimization using imagery, population, and optionally other data sources.

Responsibilities

Terragraph software initializes and configures radios (DN and CN). It tracks and optimizes meshed routing paths. It also monitors and maintains Syslog, alarm and Firmware upgrade.

cnWave family overview

Cambium Networks 60 GHz cnWave™ solution provides easy, fast and cost- effective wireless Gigabit connectivity for edge access and/or high-capacity backhaul for edge access solutions at a significantly lower cost than fiber infrastructure. Service providers and enterprises now have access to Gigabit for business and residential connectivity, backhaul for Wi-Fi access. Certified for Facebook Terragraph, 60 GHz cnWave™ mesh solutions are highly efficient at handling high-density deployments in cities and suburban areas.

Cambium Networks 60 GHz solution consists of DN which act as an Access Point (AP) and CN which acts as a cnWave client. cnWave consists of 3 variants, V5000 a dual sector Distribution Node, V3000 and V1000 are client nodes.

- 60 GHz cnWave™ V1000 is featured with wide-range, 80 degrees beam-forming for easy installation. It is powered by 802.3af PoE and supports up to 2 Gbps for both PTP and PMP configurations.

- 60 GHz cnWave™ V3000 is featured with either a 44.5 dBi high-gain antenna or 40.5 dBi lower gain antenna both with beam-forming. The client nodes can support up to 7.2 Gbps with channel bonding for PTP and PMP configurations.
- 60 GHz cnWave™ V5000 is featured with two sectors covering up to 280 degrees with beam-forming. A single V5000 can connect up to four other distribution nodes or up to 30 client nodes. V5000 can be used for PTP, PMP and Mesh configurations.



V1000



V3000 (44.5 dBi and 40.5 dBi Client Nodes)



V5000

Features

V1000 Client Node (CN)

- Supports modulations BPSK to 16 QAM (MCS1 to MCS12)
- Integrated antenna with beam forming
- 38 dBm EIRP
- Gigabit Ethernet
- 1 Gbps UL/1 Gbps DL throughput
- Powered by passive PoE or 802.3af/at PoE
- IP 66/67

V3000 Client Node (CN)

- Supports modulations BPSK to 16 QAM (MCS1 to MCS12)
- 44.5 dBi UltraGain antenna with beam forming 60.5 dBm EIRP
- 40.5 dBi UltraGain antenna with beam forming 54.5 dBm EIRP
- 10 Gigabit Ethernet
- Supports 10G SFP+ or 1G SFP
- 1.8 Gbps UL/1.8 Gbps DL and 3.6 Gbps UL/3.6 Gbps DL with channel bonding throughput
- Gigabit Ethernet Auxiliary Interface

- Powered by passive PoE
- Supports Aux PoE out (802.3af/at PoE)
- IP 66/67

V5000 Distribution Node (DN)

- Supports modulations BPSK to 16QAM (MCS1 to MCS12)
- Dual sector - 280 degree antenna with beam-forming
- 38 dBm EIRP
- 10 Gigabit Ethernet
- Supports 10G SFP or 1G SFP
- 1.8 Gbps UL/1.8 Gbps DL and 3.6 Gbps UL/3.6 Gbps DL with channel bonding throughput per sector
- Gigabit Ethernet Auxiliary Interface
- Powered by passive PoE
- Supports Aux PoE out (802.3af/at PoE)
- IP 66/67

Wireless operation

This section describes how the 60 GHz cnWave™ is operated, including topology, modulation modes, power control and security.

Wireless topology

60 GHz cnWave™ supports operation in three topologies:

- Point to point (PTP)
- Point to Multipoint (PMP)
- Mesh

PTP

The PTP topology provides a point-to-point link using V1000, V3000 and V5000.



Note

V1000 to V1000 point-to-point topology is supported.

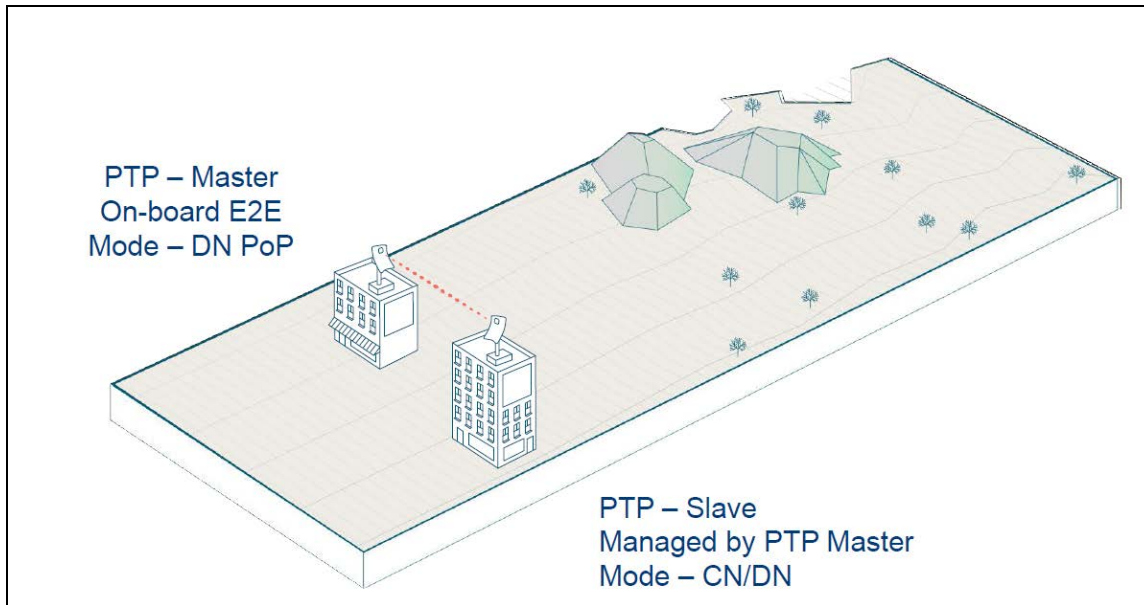

PMP

The PMP topology provides a point to multi point where V5000 acts as PoP DN and V5000, V3000, V1000 acts as APs.

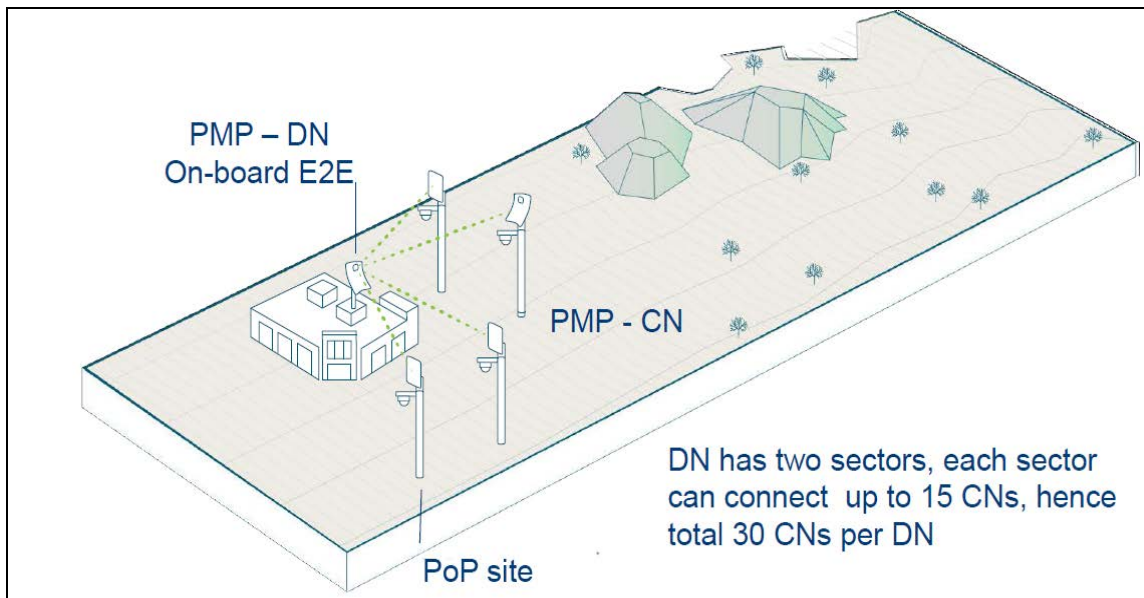

Mesh

Mesh efficiently distributes capacity and improves availability, using Open/R based layer 3 IPv6 meshing. It allows for route diversity which provides high network availability and supports up to 15 hops away from a PoP node. Network bandwidth is reduced at each hop, and the total bandwidth available in the network is limited to a PoP node's network reappearance. Mesh is distributed network application platform that determines appropriate routes between the mesh nodes.

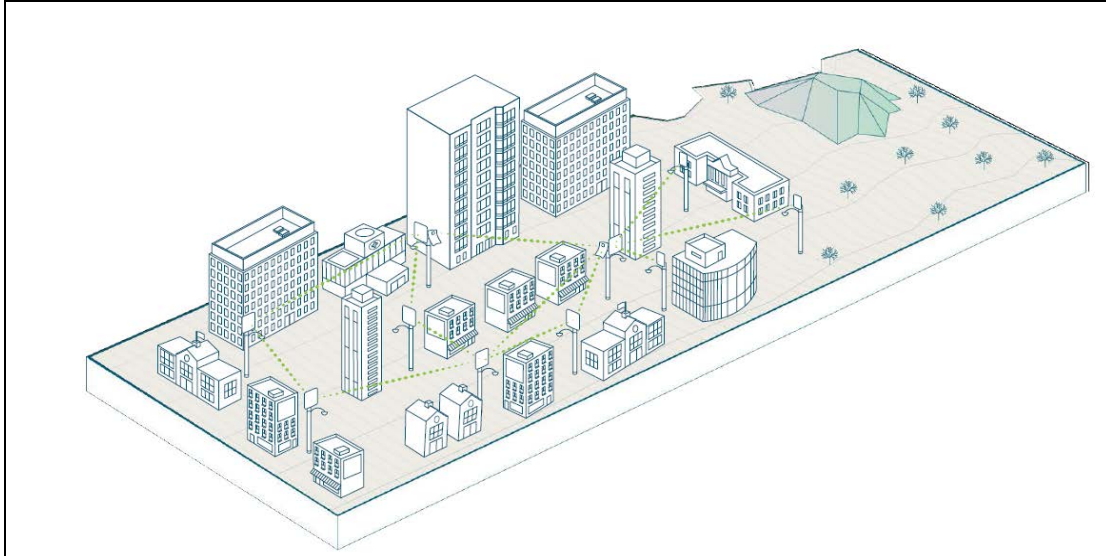

Modulation

MCS	Modulation	Coding Rate	L2 Throughput (Mb/s) (2.16 GHz Channel)	L2 Throughput (Mb/s) (4.32 GHz Channel)
2	BPSK	1/2	733.0	1466.0
3	BPSK	5/8	914.0	1828.0
4	BPSK	3/4	1085.0	2170.0
5	BPSK	4/5	1175.0	2350.0
6	QPSK	1/2	1421.0	2842.0
7	QPSK	5/8	1748.0	3496.0
8	QPSK	3/4	2059.0	4118.0
9	QPSK	4/5	2221.0	4442.0
10	16-QAM	1/2	2673.0	5346.0
11	16-QAM	5/8	3245.0	6490.0
12	16-QAM	3/4	3737.0	7474.0

Link adaption

Link adaptation is performed independently for each link for data traffic and it is closed loop based. Adjusting the Tx modulation and coding scheme from MCS2 to MCS12 selected for transmission. It is adjusted based on the following:

- Packet Error Ratio (PER)
- SNR

- local measurements of successful and unsuccessful frame transmissions (e.g. count of frames ACKed or Not ACKed)

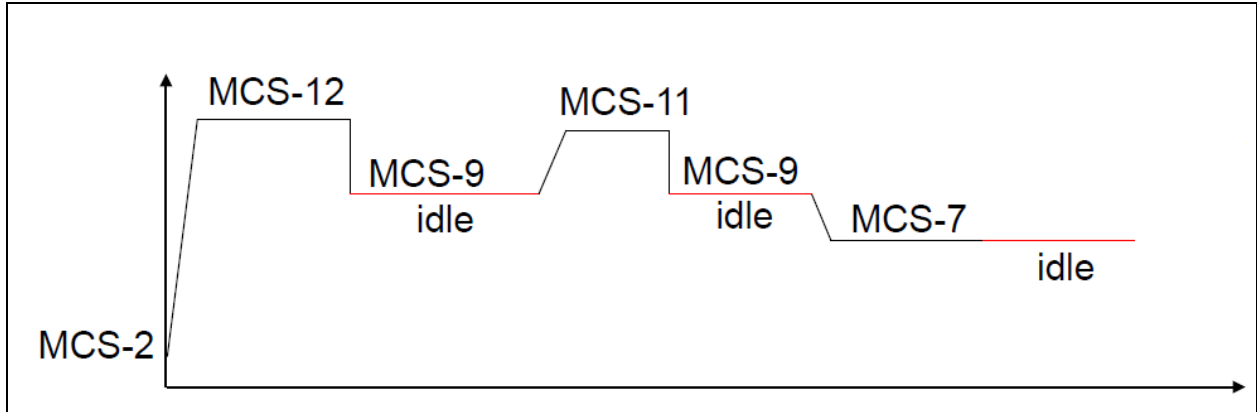

Start from MCS2, adjust based on signal quality, when the session is idle, fall back to MCS-9 or any highest MCS achieved below MCS-9.

Synchronization

Synchronization is used to control the transmit and receive signals to prevent self-interference. Radios assigned with the same polarity will be transmitting and receiving at the same time. There are two types of polarities:

- Odd (if Odd nodes are Tx)
- Even (if Even nodes are Rx)

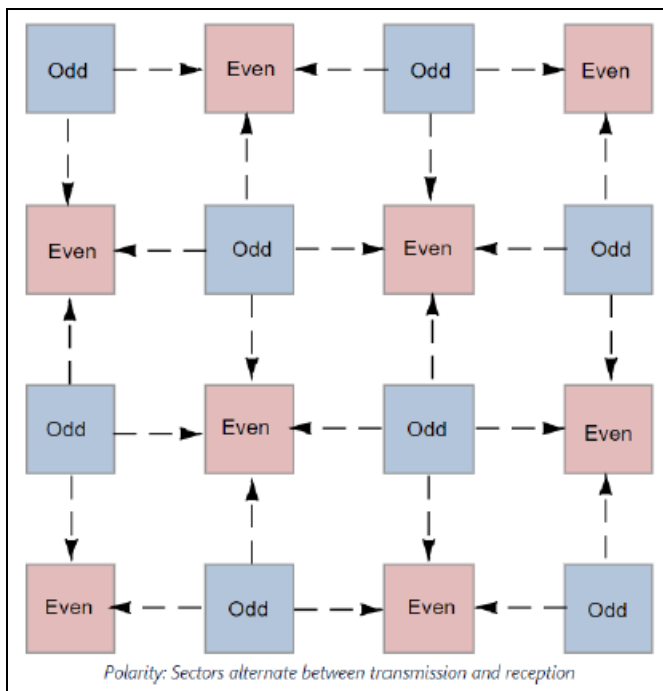

The MAC synchronizes its timers to an external, accurate time source, such as GPS or IEEE 1588. A timing pulse that resets the Timing Synchronization Function (TSF) on the DN is repeated once every second. This timing pulse occurs exactly at the turn of each second.

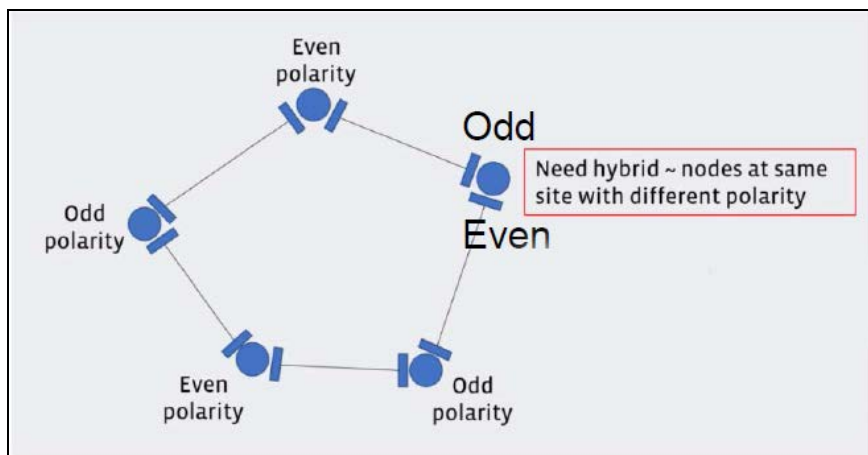

Time division duplexing access mechanism

60 GHz cnWave™ uses a Time Division Duplex (TDD) channel access mechanism. All cnWave nodes are time synchronized and this is achieved through internal GPS, IEEE 1588 (roadmap) or Cambium Sync (roadmap) and each sector of a node is assigned specific times during which it can transmit or receive. A timing pulse that resets the Timing Synchronization Function (TSF) on the DN is repeated once every second (1PPS). This timing pulse occurs exactly on the turn of each second and Sub-Frames begins every 200 micro seconds.

General operation of MAC layer

MAC is highly modified from that in IEEE 802.11-2016. Use TDD MAC by substituting TDD access for all other access. 60 GHz cnWave™ supports fixed 50-50 up/down ratio.

60 GHz cnWave™ uses only the following frames:

- Data
- QoS-Null (frame does not carry any data)
- Management Action (e.g. beamforming, etc.)
- Block ACK (used for sending ACK to multiple nodes/packets at once)
- ACK

Frame types

Below are the types of frames in 60 GHz cnWave™:

- **Management frames** - A node sends all management frames using the DMG control mode PHY, MCS 0.
- **Control frames** - A node sends the ACK frame using the DMG control mode PHY, MCS 0. A node sends the Block ACK frame using the DMG single carrier PHY, MCS 1.

- **Data frames** - A node sends data frames using MCS 2 through MCS 12 of the DMG single carrier PHY, as determined by the link adaptation algorithm.

Wireless encryption

The 60 GHz cnWave™ supports optional encryption for data transmitted over the wireless link using a choice of three different encryption algorithms:

- **TLS RSA:** The ODUs exchange RSA certificates to authorize the remote unit and agree a randomly-generated master secret. The TLS RSA option supports unencrypted operation of the wireless link, or encryption with 128-bit AES
- **TLS PSK 128-bit:** Both ends of the link are configured with the same 128-bit pre-shared key as a master secret. The wireless link is encrypted using 128-bit AES.

The Advanced Encryption Standard (AES) is a symmetric encryption algorithm approved by U.S. Government organizations (and others) to protect sensitive information. The AES implementation in 60 GHz cnWave™ is approved to FIPS 197.

The use of AES encryption in 60 GHz cnWave™ is controlled by the AES license and enabled through the purchase of a capability upgrade.



Note

Encryption Algorithm cannot be configured as TLS RSA when Access Method is Link Name Access. In this case, only the TLS PSK algorithms are supported.

Designing wireless networks

For designing wireless networks, refer [LINKPlanner](#).

TDD synchronization

Built-in GPS receiver

V3000 and V5000 have built in GPS receiver. E2E Controller manages the TDD synchronization.

System management

This section introduces the 60 GHz cnWave™ management system, including the web interface, installation, configuration, alerts and upgrades.

Management agent

60 GHz cnWave™ equipment is managed through an embedded management agent. Management workstations, network management systems or PCs can be connected to this agent using a choice of in-band or out-of-band network management modes.

The management agent includes a IPv4/IPv6 interface at the management agent. The IP interface operates in the following modes:

- IPv4 only
- IPv6 only
- Dual IPv4/IPv6

Network management

cnMaestro is a Cambium Network Management System (NMS). This is single plane to manage the complete Cambium product portfolio. It uses secure websocket for management traffic that can be used to manage all Cambium products on the same system. Configurations can be pushed from the cnMaestro through E2E to the end devices.

cnMaestro NMS is used to:

- Manage cnWave network including E2E, CN, and DN
- Show the connection topologies
- Collect KPIs/statistics, alarms, logs (via the E2E device agent)
- Performs software upgrade

IPv6

IPv6 address is 128 bits (16 Bytes) address. The subnet ID in IPv4, is called prefix in IPv6. In IPv6 Neighbor Discovery Protocol (NDP) is used with ICMPv6 to resolve the MAC address. IPV6 does not have broadcast, but has only multicast.

cnWave products use SLAAC (Stateless Address Autoconfiguration) for dynamic IPv6 address assignment. System gets the IP address dynamically by listening Router Advertisement (RA), and forms the address in EUI-64 format. RA also publishes DNS information to the devices.

System logging

Refer [Logging into the web interface](#) section for system logging.

Software upgrade

Refer [Software Upgrade](#) section for more information.

Chapter 3: System Hardware

Wireless nodes

The 60 GHz cnWave™ solution includes three types of wireless nodes:

- V1000 Client Node
- V3000 (44.5 dBi and 40.5 dBi) Client Node
- V5000 Distribution Node

V1000 Client Node

V1000 is an outdoor CN which can be connected to a distribution node wirelessly. V1000 supports Gigabit Ethernet interface and is powered by 802.3af/at PoE compliant power supply or a passive PoE.



Figure 1: V1000 Client Node front and rear views

V1000 part numbers

Order the V1000 Client Node (CN) from Cambium Networks ([V1000 CN part numbers](#)). Each V1000 CN is supplied with a mounting bracket for wall mount or pole mount, and an indoor power supply.

Table 3: V1000 CN part numbers

Cambium description	Cambium part number
60GHz cnWave V1000 Client Node with US cord	C600500C001A
60GHz cnWave V1000 Client Node with EU cord	C600500C003A
60GHz cnWave V1000 Client Node with UK Cord	C600500C004A
60GHz cnWave V1000 Client Node with ANZ Cord	C600500C008A
60GHz cnWave V1000 Client Node with Brazil Cord	C600500C009A
60GHz cnWave V1000 Client Node with Argentina Cord	C600500C010A
60GHz cnWave V1000 Client Node with China Cord	C600500C011A
60GHz cnWave V1000 Client Node with South Africa Cord	C600500C012A
60GHz cnWave V1000 Client Node with India Cord	C600500C013A

Cambium description	Cambium part number
60GHz cnWave V1000 Client Node with no Cord	C600500C014A
60GHz cnWave V1000 Client Node with Israel cord - Israel Only	C600500C016A

V3000 Client Node (CN)

V3000 is an outdoor CN which can be connected to a DN or another V3000 DN wirelessly. V3000 supports 10 Gigabit Ethernet interface, an 10G SFP+ interface port and a Gigabit Ethernet Aux interface.

V3000 can be powered using 60W passive POE or using a AC/DC PSU through mini adapter (for more information, refer power supply and cable lengths supported in [Power supply units](#) section). V3000 DN can also power 802.3af/at compliant auxiliary device through Gigabit Aux interface.



Figure 2: V3000 Client Node without antenna assembly and with 44.5 dBi and 40.5 dBi antenna assemblies

V3000 part numbers

Order the V3000 CN from Cambium Networks ([V3000 CN part numbers](#)). The V3000 CN radio is supplied without an antenna assembly, bracket or power supply. See [Precision brackets](#) for details of suitable brackets and power supplies.



Note

Use a dedicated antenna assembly for V3000 CN.

Order the antenna assembly required for each CN radio.

Table 4: V3000 CN part numbers

Cambium description	Cambium part number
60 GHz cnWave V3000 CN radio only	C600500C024A
60 GHz cnWave V3000 CN antenna assembly, 44.5 dBi	C600500D001A
60 GHz cnWave V3000 CN antenna assembly, 40.5 dBi, 4 Pack	C600500D002A
60 GHz cnWave V3000 CN antenna assembly, 44.5 dBi, 4 Pack	C600500D003A
60 GHz cnWave V3000 CN Radio only - Israel Only	C600500C025A

V5000 Distribution Node (DN)

V5000 is an outdoor DN which can be connected to a multiple V1000 or V3000 CNs wirelessly. V5000 supports 10 Gigabit Ethernet interface, an 10G SFP+ interface port and a Gigabit Ethernet Aux interface.

V5000 can be powered using 60W passive POE or using a AC/DC PSU through mini adapter (for more information, refer power supply and cable lengths supported in [Power supply units](#) section). V5000 DN can also power 802.3af/at compliant auxiliary device through Gigabit Aux interface.



Figure 3: V5000 Distribution Node front and rear views

V5000 part numbers

Order the V5000 Distribution Node (DN) from Cambium Networks ([V5000 DN part numbers](#)). The V5000 DN is supplied without a mounting bracket or power supply.

Table 5: V5000 DN part numbers

Cambium description	Cambium part number
60GHz cnWave V5000 DN	C600500A004A
60GHz cnWave V5000 Distribution Node - Israel Only	C600500A005A

Radio mounting brackets

V1000 wall and pole mount (C000000L136A and C000000L137A)

The V1000 CN is supplied with a mounting plate and band clamp. The mounting plate can be used for mounting the V1000 on a wall, or it can be used with the band clamp to mount the V1000 on a pole with diameter in the range 40 mm to 77 mm (1.6 inches to 3.03 inches).



Figure 4: V1000 mounting plate and band clamp

V1000 adjustable pole mount (N000900L022A)

The adjustable pole mount is used to provide elevation adjustment when a V1000 CN is mounted on a pole. The adjustable pole mount works with poles with diameter in the range 40 mm to 77 mm (1.6 inches to 3.03 inches).



Figure 5: V1000 adjustable pole mount

V3000 precision bracket (C000000L125A)

The precision bracket ([Precision bracket](#) figure below) is used to mount the V3000 CN on a vertical pole with diameter in the range 25 mm to 80 mm (0.98 inches to 3.14 inches). The precision bracket provides fine adjustment of up to 18° in azimuth and +/-30° in elevation for accurate alignment of the V3000.

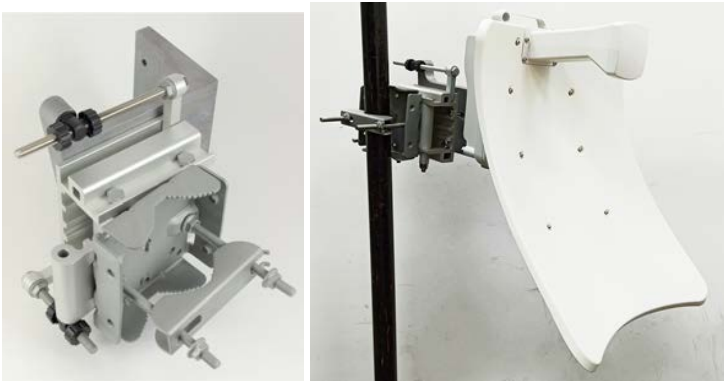

Figure 6: Precision bracket



Bracket body



Long (120 mm) M8 screws and flange nuts



40 mm M8 screws, plain washers and Nyloc nuts



28 mm M6 screws, M8 spacers and pole mount clamp

Azimuth arm



Bracket base



V3000 mount

Figure 7: Precision bracket components

V3000 tilt bracket (N000045L002A)

The tilt bracket ([Tilt bracket assembly](#) figure below) is used to provide elevation adjustment when a V3000 CN or V5000 DN is mounted on a pole. The tilt bracket works with poles with diameter in the range 25 mm to 80 mm (0.98 inches to 3.14 inches). The tilt bracket assembly may be used with third-party band clamps to mount the ODU on larger pole with diameter in the range 90 mm to 230 mm (3.54 inches to 9.05 inches).



Figure 8: Tilt bracket assembly

V5000 pole mount (C000000L137A)

The pole mount ([Pole mount](#) figure below) is used to mount a V5000 DN on a vertical pole with diameter in the range 25 mm to 80 mm (0.98 inches to 3.14 inches). It provides coarse azimuth (but not elevation) adjustment.



Figure 9: Pole mount

V5000 wall mount (C000000L136A)

The wall mount ([Wall mount](#) figure below) is used to mount a V5000 DN on a vertical wall. It does not provide azimuth or elevation adjustment. The wall mount requires additional fixing hardware suitable for the type of wall.



Figure 10: Wall mount

Bracket part numbers

Order mounting brackets using the Cambium part number in [Radio mounting bracket part numbers](#) table below.

Table 6: Radio mounting bracket part numbers

Bracket	Radio nodes	Cambium Part Number
Adjustable pole mount	V1000	N000900L022A
Tilt bracket assembly	V3000	N000045L002A
Wall mount bracket	V5000	C000000L136A
Pole mount bracket	V5000	C000000L137A
Precision bracket	V3000	C000000L125A

Radio accessories

Telescope mounting kit for precision brackets

An alignment telescope provides the most accurate option for alignment of the precision bracket during installation. The telescope is temporarily mounted on the bracket using the telescope mounting kit for precision brackets.

The telescope mounting kit consists of a mounting plate, a knurled screw and two rubber O-rings.

Order the telescope mounting kit from Cambium Networks.



Figure 11: Telescope mounting kit

Order a suitable telescope from a specialist supplier specifying the following:

- Right angle, erecting, 9x50 mm alignment scope with 5° field of view



Figure 12: Typical alignment telescope

Accessory part numbers

Order radio accessories using the Cambium Part Number in [Radio accessory part numbers](#) table below.

Table 7: Radio accessory part numbers

Accessory	Radio nodes	Cambium Part Number
Telescope mounting kit	V3000	C000000L139A

Radio external interfaces

V1000 Client node



Figure 13: External interfaces for V1000 CN

Table 8: External interfaces V1000 CN

Port name	Connector	Interface	Description
PSU	RJ45	PoE input	Standard 802.3af/at PoE
		100/1000 BASE-T Ethernet	Data and management

V3000 Client node



Figure 14: External interfaces for V3000 CN

Table 9: External interfaces V3000 CN

Port name	Connector	Interface	Description
SFP+	SFP	10G BASE-SR/10G BASE-LR/1G Base-SX using optional SFP+/SFP optical or copper module SFP-1G-SX / SFP-1G-LX using optional SFP optical or copper module	Data and management
PSU	RJ45	PoE input	Passive PoE
		100m/1000m/2.5G BASE-T/5G BASE-T/ 10G BASE-T Ethernet	Data and management
AUX	RJ45	PoE output	Standard IEEE 802.3af/at
		100/1000 BASE-T Ethernet	Data and management

V5000 Distribution node

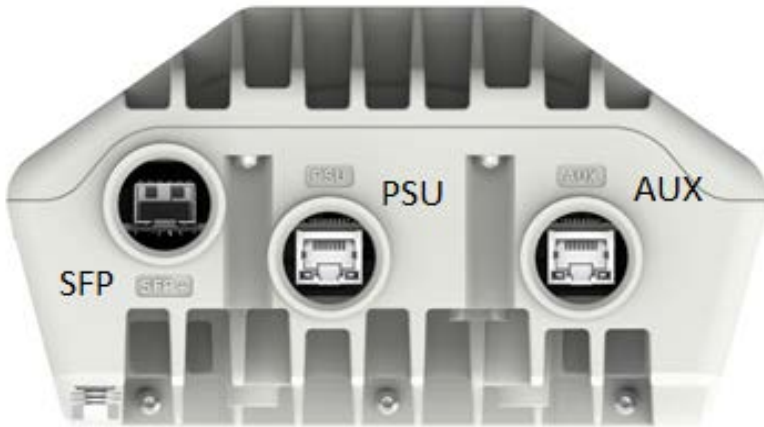

Figure 15: External interfaces for V5000 DN

Table 10: External interfaces V5000 DN

Port name	Connector	Interface	Description
SFP+	SFP	10G BASE-SR/10G BASE-LR/1G Base-SX using optional SFP+/SFP optical or copper module SFP-1G-SX / SFP-1G-LX using optional SFP optical or copper module	Data and management

Port name	Connector	Interface	Description
PSU	RJ45	PoE input	Passive PoE
		100m/1000m/2.5G BASE-T/5G BASE-T/ 10G BASE-T Ethernet	Data and management
AUX	RJ45	PoE output	Standard IEEE 802.3af/at
		100/1000 BASE-T Ethernet	Data and management

Radio specifications

The 60 GHz cnWave™ Radios conform to the specifications listed in [Radio node specifications](#).

Table 11: Radio node specifications

Category	Specification	
Dimensions	V1000 Client Node	140 mm ×85 mm ×40 mm (5.5 in ×3.3 in ×1.6 in)
	V3000 Client Node (44.5 dBi)	348 mm x 415 mm x 349 mm (13.7 in x 16.3 in x 13.7 in)
	V3000 Client Node (40.5 dBi)	198 mm x 340 mm x 251 mm (7.8 in x 13.3 in x 9.9 in)
	V5000 Distribution Node	280 mm ×185 mm ×102 mm (11.0 in ×7.3 in × 4.0 in)
Weight	V1000 Client Node	0.25 kg (0.55 lbs)
	V3000 Client Node (44.5 dBi)	4.7 kg (10.3 lbs) including antenna
	V3000 Client Node (40.5 dBi)	3.9 kg (8.6 lbs) including antenna
	V5000 Distribution Node	4.0 kg (8.8 lbs) including antenna
Temperature	-40°C (-40°F) to +60°C (140°F)	
Wind survival	200 kph (124 mph) maximum	
Humidity	100% condensing	
Liquid and particle ingress	IP66, IP67	
Power consumption	V1000 Client Node	10 W
	V3000 Client Node	30 W, up to 55 W with PoE out enabled
	V5000 Distribution Node	35 W, up to 60 W with PoE out enabled

Category	Specification	
Power input interface	V1000 Client Node	IEEE 802.3af
	V3000 Client Node	Passive PoE
	V5000 Distribution Node	Passive PoE
Power output interface	V3000 Client Node	IEEE802.3af/at, 25 W maximum
	V5000 Distribution Node	IEEE 802.3af/at, 25 W maximum

Theory of operation

60 GHz cnWave™ devices support Facebook connectivity technology called **Terragraph**. cnWave™ devices implement IEEE 802.11ay WLAN standard and use 60GHz frequency band for wider spectrum and higher capacity. cnWave™ devices can provide multi-gigabit throughput from 100 M to 1.5 KM.

Deployment of the devices use Open/R based layer3/IPv6 mesh for efficient distribution of traffic between the nodes and higher availability of the traffic. This also overcomes non-line of sight issues.

Devices use TDMA/TDD technology in order to achieve density deployment efficiency. Network and the nodes are configured, controlled and monitored by cloud based E2E Controller.

Following terminologies are used for the network deployment:

- **Distribution Node (DN)** - DN connects with other DN for mesh network
- **Client Node (CN)** - CN connects to DN to provide high speed connectivity
- **PoP** - DN connected to the back-haul
- **CPE** - Customer premises devices like Wi-Fi router

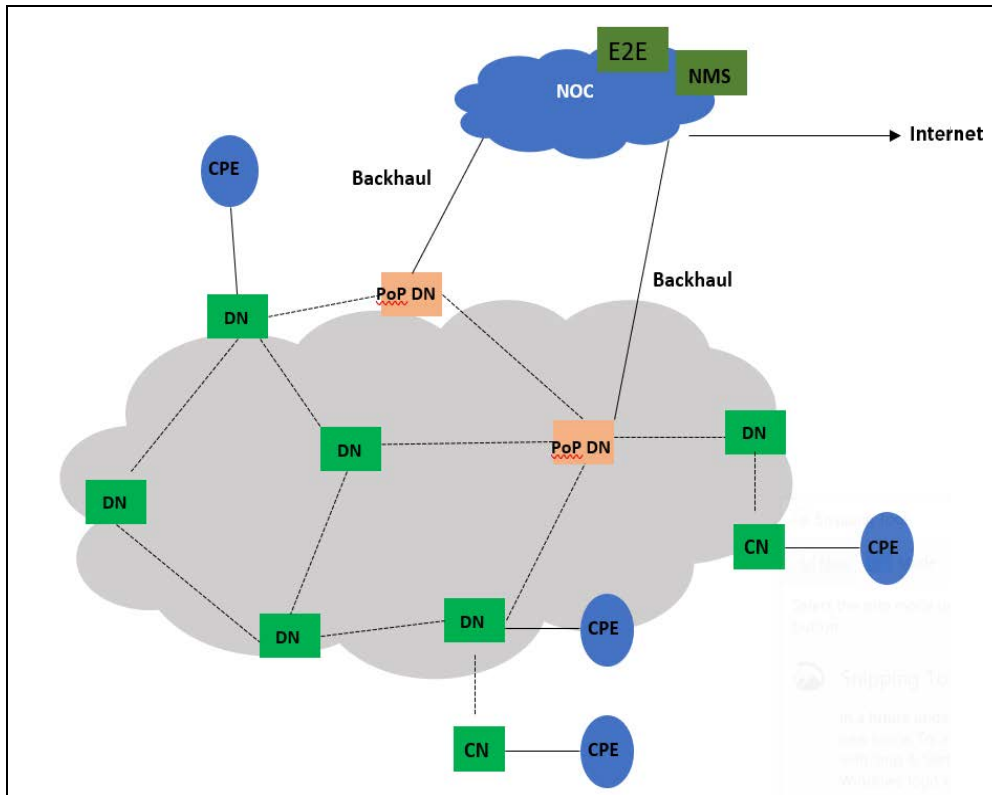

Figure 16: Deployment scenario

Power supply units (PSU)

PSU options

Order PSUs from Cambium Networks. Power supply component and the part numbers are described in the following table.

Table 12: Power supply component part numbers

Cambium description	Radio node	Cambium part number
Outdoor AC/DC PSU, 100W, 54V DC	V3000, V5000	N000000L179B
Waterproof PSU Cable Joiner 14-16 AWG	V3000, V5000	N000000L180A
DC to RJ45 Plug Power Adaptor	V3000, V5000	C000000L184A
Cable Gland, Long, M25, Qty 5	V3000, V5000	C000000L124A
PoE, 60W, 56V, 5GbE DC Injector, Indoor, Energy Level 6 Supply	V3000, V5000	N000000L142A
PoE, 60W, 56V, 10GbE DC Injector, Indoor, Energy Level 6 Supply	V3000, V5000	C000000L141A
PoE Gigabit DC Injector, 15W Output at 56V, Energy Level 6, 0C	V1000	N000900L017A

Cambium description	Radio node	Cambium part number
to 50C		
AC power Injector 56V, 60W	V3000, V5000	N000065L001C
CABLE, UL POWER SUPPLY CORD SET, 720mm, AUS/NZ	V1000, V3000, V5000	N000900L011A
CABLE, UL POWER SUPPLY CORD SET, INDIA	V1000, V3000, V5000	N000900L012A
CABLE, UL POWER SUPPLY CORD SET, ARGENTINA	V1000, V3000, V5000	N000900L013A
CABLE, UL POWER SUPPLY CORD SET, CHINA	V1000, V3000, V5000	N000900L015A
CABLE, UL POWER SUPPLY CORD SET, 720mm, US	V1000, V3000, V5000	N000900L031A
CABLE, UL POWER SUPPLY CORD SET, 720mm, EU	V1000, V3000, V5000	N000900L032A
CABLE, UL POWER SUPPLY CORD SET, 720mm, UK	V1000, V3000, V5000	N000900L033A
CABLE, UL POWER SUPPLY CORD SET, 720mm, Brazil	V1000, V3000, V5000	N000900L034A
CABLE, UL POWER SUPPLY CORD SET, 720mm, Israel	V1000, V3000, V5000	N000900L037A

Refer [Maximum cable lengths](#) for details of the maximum cable lengths and the maximum PoE output power for different powering options.

V1000 power over Ethernet

The V1000 CN is always powered using power over Ethernet (PoE) at a nominal 56V, as shown in [PoE power supply to V1000](#) figure using the Gigabit power injector supplied with the radio, or using an IEEE 802.3af PoE output from an Ethernet switch.





Figure 17: PoE power supply to V1000

Table 13: PoE, 15W 56V, 1 Gigabit DC injector (N000900L017A)

Category	Specification
Dimensions	118 mm (4.64 in) x 43 mm (1.69 in) x 32.4 mm (1.27 in)
Weight	0.18 Kg (0.39 lbs)
Temperature	0°C (32°F) to +50°C (140°F)
Humidity	10% to 95 % non-condensing
AC Input	90-264V AC, 47-63 Hz
DC Output Voltage	56V
DC Output current	0.25A
Efficiency	Better than 84% at full load
Over Current Protection	Hiccup mode, recovers automatically after fault condition is removed
Hold up time	At least 10 milliseconds
RJ45 POE Port	7,8 ----- DC V- 5,6 ----- DC V+



Note

The Gigabit power injector is supplied with the cnWave V1000 CN. Order part N000900L017A to obtain spares.



Warning

Always use an appropriately rated and approved AC supply cord-set in accordance with the regulations of the country of use.

V3000, V5000 Power over Ethernet

The V3000 CN and V5000 DN can be powered using DC power at a nominal 54V, using 14 AWG or 16 AWG cable, as shown in [DC power supply to V3000 or V5000](#) figure.

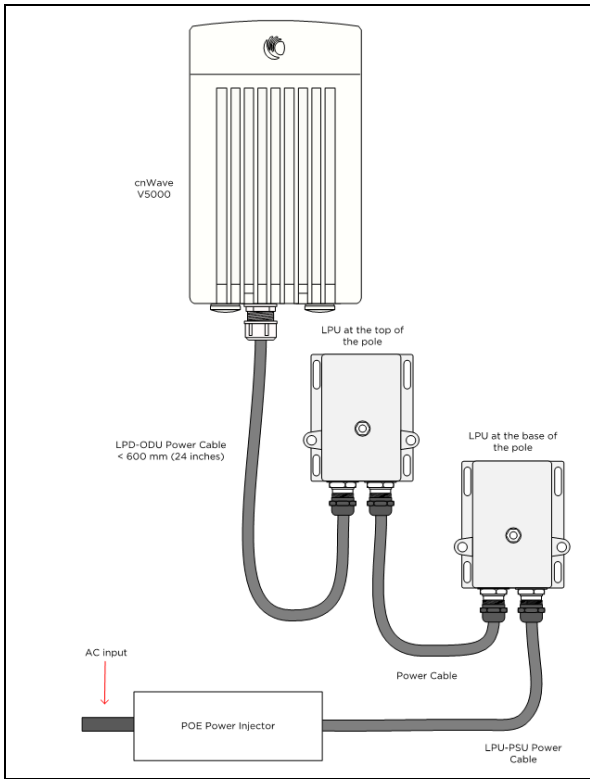

Table 14: PoE, 60W, 56V, 5 GbE DC injector (N000000L142A)

Category	Specification
Dimensions	140 mm (5.5 in) x 53 mm (2.08 in) x 35 mm (1.37 in)
Weight	0.24 Kg (0.5 lbs)
Temperature	0°C (32°F) to +50°C (140°F)
Humidity	10% to 95 % non-condensing
AC Input	90-264 V AC, 47-63 Hz
DC Output voltage	56V
DC Output current	1.07 A
Efficiency	Better than 88% at full load
Over Current Protection	Hiccup mode, recovers automatically after fault condition is removed
Hold up time	At least 10 milliseconds
RJ45 POE Port	1,2,7,8 ----- DC V- 3,4,5,6 ----- DC V+

V3000, V5000 outdoor AC/DC power supply unit

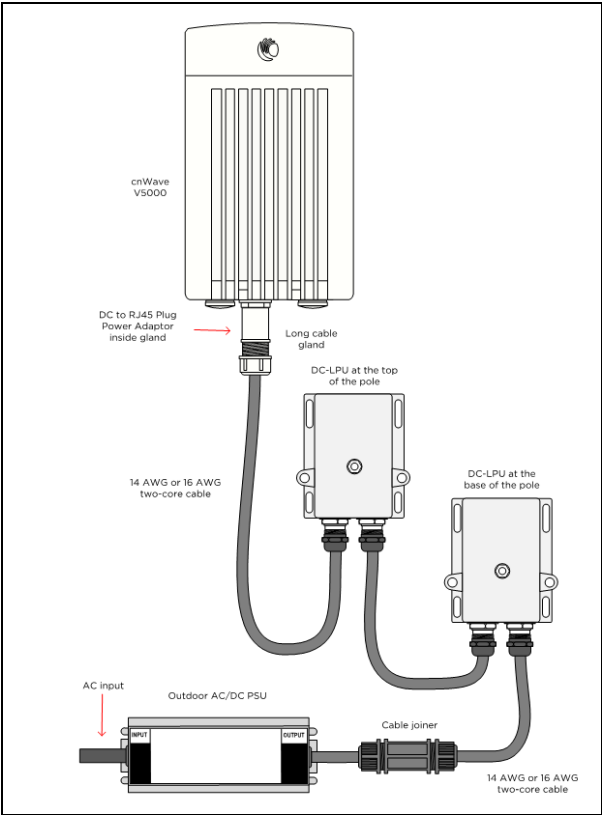

Figure 18: DC power supply to V3000 or V5000

The outdoor PSU can be installed indoors, in an outdoor cabinet, or inside street furniture.



Figure 19: Outdoor AC/DC PSU, 60 W, 54 VDC



Figure 20: Outdoor AC/DC PSU, 100 W, 54 VDC (N000000L179B)

Table 15: Outdoor AC/DC PSU, 54 VDC

Category	PSU	Specification
Partnumber and Dimensions	N000000L178A (60W)	171 mm (6.7 in) x 62 mm (2.4 in) x 37 mm (1.5 in)
	N000000L179A(100W)	220 mm (8.7 in) x 68 mm (2.7 in) x 39 mm (1.5 in)
Power	60W	
	100W	
Temperature	-40°C (-40°F) to +60°C (140°F)	
Humidity	20 to 95 % non-condensing	
Waterproofing	IP65/IP67	
AC Input	90-305 V AC, 47-63 Hz	
DC Output Voltage	54V	
DC Output current	60W	1.15 A
	100W	1.77 A

Category	PSU	Specification
Efficiency	Better than 90% at full load	
Over Current Protection	Hiccup mode, recovers automatically after fault condition is removed	
Hold up time	At least 16 milliseconds	
Power factor	Better than 0.95	



Figure 21: Cable joiner



Figure 22: DC to RJ45 plug power adapter

These cable joiners and DC to RJ45 cable adapters are used to connect to outdoor AC/DC PSU. Refer [Maximum cable lengths](#) for details of the maximum cable lengths and the maximum PoE output power for different powering options.

PSU specifications

The PSUs conform to the specifications listed in [Outdoor AC/DC PSU, 54VDC](#).

Ethernet and DC cables

Maximum cable lengths

Ethernet

For all cnWave radios, the maximum cable length for data transmission over copper Ethernet (100BASE-TX, 1000BASE-T, 2.5GBASE-T, 5GBASE-T, 10GBASE-T) is 100 m (328 ft) from the radio to the connected

equipment.

It is recommended to use outdoor braided **CAT6A** cable for V3000, V5000 and outdoor braided **CAT5e** cable for V1000.

For installations where auxiliary device is powered using ODU Aux POE port, refer [Maximum cable lengths supported](#) table.

The maximum cable length for fiber Ethernet (10GBASE-SR, 10GBASE-LR) connections depends on the fiber used. See SFP module kits on page 19 for details of the Ethernet standards supported and maximum permitted cable lengths.

Power over Ethernet

The maximum length for supplying power from a 60 W DC injector over a CAT6A Ethernet cable is shown in [Maximum cable length for power over Ethernet](#) table. 60W DC injector is used to power on the V3000 or V5000.

Table 16: Maximum cable length for power over Ethernet supported on V3000 and V5000

Radio	PoE enabled	Maximum cable length
V3000	-	390m
	25W	72m
V5000	-	330m
	25W	Not supported

The available output power for auxiliary Power over Ethernet output in V3000 and V5000 is reduced at longer PoE cable lengths, as shown in [Maximum cable length for power over Ethernet](#) table.

Table 17: Maximum PoE output power

Radio	Cable length	Maximum Aux PoE output
V3000	0m to 72m	25.0W
	25m	24.6W
	100m	23.6W
V5000	10m	23.1 W
	20m	22.6W
	30m	22.1W
	40m	21.6W
	60m	20.6W
	80m	19.6W
	100m	18.6W

Using AC/DC PSU with a DC power feed

The maximum length for supplying power over a CAT6A Ethernet cable is shown in [Maximum cable length for DC power](#) table.

Table 18: Maximum cable length for DC power

Radio	PSU	PoE enabled	Maximum cable length 14 AWG	Maximum cable length 16 AWG
V3000	60W	-	780m	490m
		25W	140m	90m
	100W	-	780m	490m
		25W	390m	250m
V5000	60W	-	660m	410m
		25W	Not supported	
	100W	-	660m	410m
		25W	360m	220m

Outdoor copper CAT6A Ethernet cable

Select an outdoor rated CAT6A cable, ready terminated with RJ45 connectors in the one of the following lengths:

- 25m
- 50m
- 100m

Alternatively, terminate bulk CAT6A cable with RJ45 connectors at a length to suit each installation.



Attention

Always use CAT6A or better cable that has an overall copper braid shield, outdoor rated, with UV-resistant sheath.

Table 19: Terminated Ethernet cable part numbers

Cambium description	Cambium part number
CAT6A outdoor cable, 305m	N000082L172B
RJ45 connector for CAT6A cable	N000082L174B
CAT6A outdoor cable, 100m	N000000L155A
Cable gland for 4-6mm cable, M25, Qty 10	C000000L176A
Cable gland for 6-9mm cable, M25, Qty 10	C000000L123A
CAT5E Outdoor Cable, 100m drum	N000082L016A

Cable accessories



Figure 23: Standard cable gland



Figure 24: Long cable gland

Cable accessories available from Cambium Networks are listed in [Cable accessory part numbers](#) table below.

Table 20: Cable accessory part numbers

Cambium description	Cambium part number
Cable gland for 6-9mm cable, M25, Qty 10	C000000L123A
Cable gland Long, M25, Qty 5	C000000L124A
Grounding cable, 0.6m with M6 ring to M6 ring	C000000L138A
Cable gland for 4-6mm cable, M25, Qty 10	C000000L176A
DC to RJ45 plug power adapter	C000000L184A
Grounding cable, 1m with M6 ring to M6 ring	N000082L116A



Note

One cable gland for 6-9mm cable size is included with each cnWave radio. Order additional cable glands as spares, where smaller cable size is to be used, or where the V3000 or V5000 Aux port is to be used.

SFP module kits

SFP module kits allow connection of a V3000 CN or V5000 DN radio to a network over a 10 Gigabit optical Ethernet interface in one of the following full-duplex modes:

- 10GBASE-SR
- 10GBASE-LR

Order SFP+ module kits from Cambium Networks ([SFP module part numbers](#)).

The SFP+ module must be used with the long cable gland.

Table 21: SFP module part numbers

Cambium description	Cambium part number
10G SFP+ MMF SR Transceiver, 850nm. -40C to 85C	SFP-10G-SR
10G SFP+ SMF LR Transceiver, 1310nm. -40C to 85C	SFP-10G-LR
1G SFP MMF SX Transceiver, 850nm. -40C to 85C	SFP-1G-SX
1G SFP SMF LX Transceiver, 1310nm. -40C to 85C	SFP-1G-LX
10G SFP+ BaseT (RJ45), -40C to 85C	SFP-10G-Cu-EXT
1000Base-T (RJ45) SFP Transceiver. -40C to 85C	SFP-1G-Copper

Optical cable and connectors

Order an optical cable with LC connectors from a specialist fabricator, quoting the specification shown in [Optical optic cable and connector specification](#). It must be the correct length to connect the ODU to the other device. LC connectors should be supplied with dust caps to prevent dust build up.

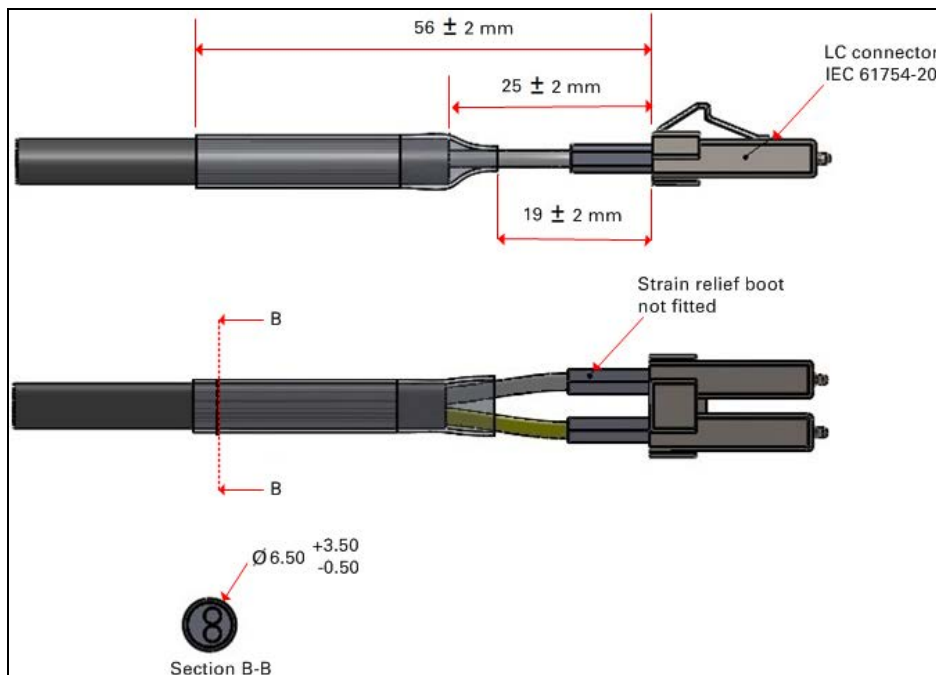

Figure 25: Optical optic cable and connector specification

Table 22: Optical cable part numbers

Cambium description	Cambium part number
Optical CABLE,MM, 1m	N000082L215A
Optical CABLE,MM, 2.2m	N000082L191A
Optical CABLE,MM, 10m	N000082L192A
Optical CABLE,MM, 20m	N000082L193A
Optical CABLE,MM, 30m	N000082L194A
Optical CABLE,MM, 50m	N000082L195A
Optical CABLE,MM, 80m	N000082L196A
Optical CABLE,MM, 100m	N000082L197A
Optical CABLE,MM, 150m	N000082L198A
Optical CABLE,MM, 200m	N000082L199A
Optical CABLE,MM, 300m	N000082L200A
Optical CABLE,SM, 2.2m	N000082L186A
Optical CABLE,SM, 10m	N000082L187A
Optical CABLE,SM, 20m	N000082L188A
Optical CABLE,SM, 30m	N000082L139A
Optical CABLE,SM, 50m	N000082L140A
Optical CABLE,SM, 80m	N000082L141A
Optical CABLE,SM, 100m	N000082L142A
Optical CABLE,SM, 150m	N000082L143A
Optical CABLE,SM, 200m	N000082L189A
Optical CABLE,SM, 300m	N000082L190A

Chapter 4: System Planning

Site planning

This section describes factors to be considered when planning the proposed link end sites, including grounding, lightning protection, and equipment location for the ODU and PSU.

Grounding and lightning protection



Warning
Electro-magnetic discharge (lightning) damage is not covered under warranty. The recommendations in this guide, when followed correctly, give the user the best protection from the harmful effects of EMD. However, 100% protection is neither implied nor possible.

Structures, equipment and people must be protected against power surges (typically caused by lightning) by conducting the surge current to ground via a separate preferential solid path. The actual degree of protection required depends on local conditions and applicable local regulations. To adequately protect a 60 GHz cnWave™ installation, both ground bonding and transient voltage surge suppression are required.

Full details of lightning protection methods and requirements can be found in the International Standards **IEC 61024-1** and **IEC 61312-1**, the U.S. National Electric Code ANSI/NFPA No. 70-1984 or section 54 of the Canadian Electric Code.



Note
International and national standards take precedence over the requirements in this guide.

Lightning protection zones

Use the rolling sphere method (Rolling sphere method to determine the lightning protection zones) to determine where it is safe to mount equipment. An imaginary sphere, typically 50 meters in radius, is rolled over the structure. Where the sphere rests against the ground and a strike termination device (such as a finial or ground bar), all the space under the sphere is in the zone of protection (Zone B). Similarly, where the sphere rests on two finials, the space under the sphere is in the zone of protection.

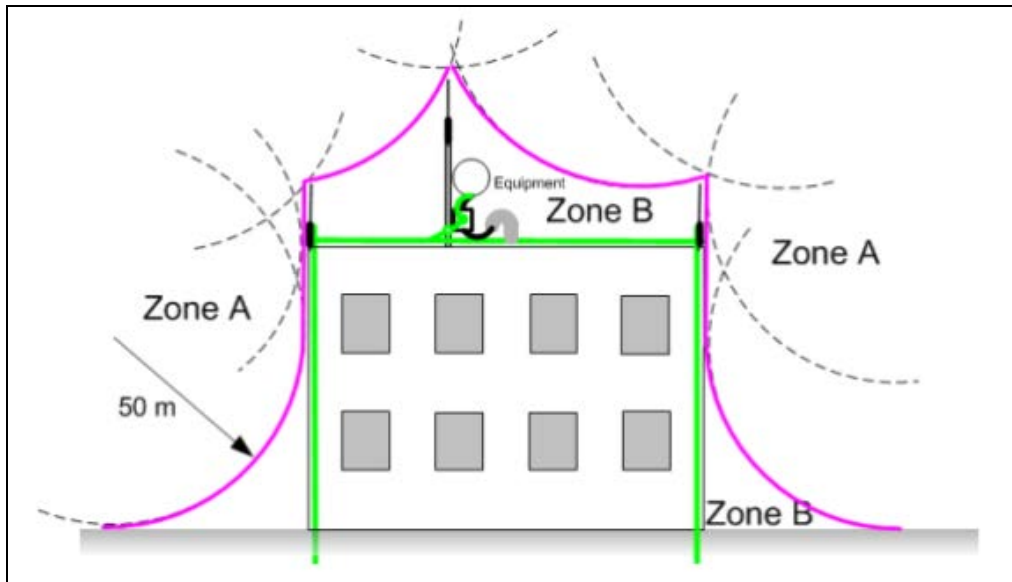

Figure 1: Rolling sphere method to determine the lightning protection zones



Warning

Never mount equipment in Zone A. Mounting in Zone A may put equipment, structures and life at risk.

Site grounding system

Ensure that the site has a correctly installed grounding system on a common ground ring with access points for grounding ODU.

If the outdoor equipment is to be installed on the roof of a high building, refer to [Installation](#) section.

Ensure that the system meets the following additional requirements:

- A grounding conductor is installed around the roof perimeter to form the main roof perimeter lightning protection ring.
- Air terminals are installed along the length of the main roof perimeter lightning protection ring, typically every 6.1 m (20 ft).
- The main roof perimeter lightning protection ring contains at least two down conductors connected to the grounding electrode system. The down conductors should be physically separated from one another, as far as practical.

ODU location

Find a location for the ODU (and external antenna for connectorized units) that meets the following requirements:

- The equipment is high enough to achieve the best radio path.
- People can be kept a safe distance away from the equipment when it is radiating.

- The equipment is lower than the top of the supporting structure (tower, mast or building) or its lightning air terminal.
- If the ODU is connectorized, select a mounting position that gives it maximum protection from the elements, but still allows easy access for connecting and weather proofing the cables. To minimize cable losses, select a position where the antenna cable lengths can be minimized. If diverse or two external antennas are being deployed, it is not necessary to mount the ODU at the mid-point of the antennas.

Drop cable grounding points

To estimate how many grounding kits are required for each drop cable, refer to site installation and use the following criteria:

- The drop cable shield must be grounded near the ODU at the first point of contact between the drop cable and the mast installation, tower or building.
- The drop cable shield must be grounded at the building entry point.

For mast or tower installations installation, use the following additional criteria:

- The drop cable shield must be grounded at the bottom of the tower, near the vertical to horizontal transition point. This ground cable must be bonded to the tower or tower ground bus bar (TGB), if installed.
- If the tower is greater than 61 m (200 ft) in height, the drop cable shield must be grounded at the tower midpoint, and at additional points as necessary to reduce the distance between ground cables to 61 m (200 ft) or less.
- In high lightning-prone geographical areas, the drop cable shield must be grounded at spacing between 15 to 22 m (50 to 75 ft). This is especially important on towers taller than 45 m (150 ft).

For roof installations, use the following additional criteria:

- The drop cable shield must be bonded to the building grounding system at its top entry point (usually on the roof).
- The drop cable shield must be bonded to the building grounding system at the entry point to the equipment room.

ODU wind loading

Ensure that the ODU and the structure on which it is mounted are capable of withstanding the prevalent wind speeds at a proposed site. Wind speed statistics should be available from national meteorological offices.

The ODU and its mounting bracket are capable of withstanding wind speeds of up to 325 kph (200 mph).

Wind blowing on the ODU subjects the mounting structure to significant lateral force. The magnitude of the force depends on both wind strength and surface area of the ODU. Wind loading is estimated using the following formulae:

- Force (in newtons) = $0.5 \times \rho \times V^2 \times A \times C_d$
 - “ ρ ” is the density of air (1.225 kg/m³)
 - “V” is the wind speed in meters per second

- “A” is the projected surface area of the ODU in square meters
- “C_d” is the drag coefficient = 1.385.

The drag co-efficient has been measured when the cover plate or antenna is perpendicular to the air flow.

Applying these formulae to the cnWave ODU at different wind speeds, the resulting wind loadings are shown in following [ODU wind loading \(newtons\)](#) table.

Table 23: ODU wind loading (newtons)

Type of ODU	Max surface area (square meters)	Wind speed (km/h Newtons)					
		200*	225	250	275	300	325
V1000	0.017544	67	85	105	127	151	177
v3000**	0.1764	462	583	719	871	1036	1216
V5000	0.052597188	118	148	185	224	266	312

Equivalent results in US customary units are shown in following [ODU wind loading \(pounds force\)](#) table.

Table 24: ODU wind loading (pounds force)

Type of ODU	Max surface area (square meters)	Wind speed (km/h lbf)					
		200*	225	250	275	300	325
V1000	0.017544	15	19	24	28	34	40
v3000**	0.1764	104	131	162	196	233	273
V5000	0.052597188	27	33	42	50	60	70

* 200 km/h is from measured data and used to calculate the remaining figures.

** Worst case setup with the product in -30° tilt position.

PSU DC power supply

Use Cambium Networks recommended DC PSU for wireless nodes and ensure the power cords and cables are appropriately rated and in accordance with the regulations of the country of use.

PSU AC power supply

Use Cambium recommended AC power supply for wireless nodes and ensure the power cords and cables are appropriately rated and in accordance with the regulations of the country of use.

PSU location

Find a location for the PSU that meets the following requirements:

DC PoE power injector

- DC power injector can be mounted on a flat surface.
- PSU is installed in a dry location where no condensation, flooding or rising damp is possible.

- The PSU is located in an environment where it is not likely to exceed its operational temperature rating, allowing for natural convection cooling and placed not close to any fire source.
- PSU can be connected to the ODU drop cable and network terminating equipment.
- PSU can be connected to a compatible power supply.

Outdoor AC/DC PSU

Find a location for the PSU that meets the following requirements:

- The PSU is installed in a dry location where no flooding or rising damp is possible.
- The PSU is located in an environment where it is not likely to exceed its operational temperature rating, allowing for natural convection cooling and placed not close to any fire source.
- The PSU is not stacked and placed on the adjacent to the heat generating equipment.
- The PSU shall be connected to protective earth.
- The PSU shall be connected to ODU drop cable using cable joiner and appropriate rated cables can be used.

Lightning Surge Protection Units (LPU)

All drop cables connected to the ODU (e.g. PSU and AUX drop cables) requires their own Lightning Protection Unit (LPU) or Gigabit Surge Suppressor installed close to the ODU and close to the enclosure/building entry point. The copper SFP drop cable also requires surge protection. Optical cables does not require lightning surge protection or ground cables. Guidance on the positioning of required lightning surge protection is given in [Lightning Surge Protection Units Location](#).

Drop cable grounding points

To estimate how many grounding kits are required for each drop cable, use the following criteria:

- The drop cable shield must be grounded near the ODU at the first point of contact between the drop cable and the mast, tower or building.
- The drop cable shield must be grounded at the building entry point.

For mast or tower installations, use the following additional criteria:

- The drop cable shield must be grounded at the bottom of the tower, near the vertical to horizontal transition point. This ground cable must be bonded to the tower or TGB, if installed.
- If the tower is greater than 61 m (200 ft) in height, the drop cable shield must be grounded at the tower midpoint, and at additional points as necessary to reduce the distance between ground cables to 61 m (200 ft) or less.
- In high lightning-prone geographical areas, the drop cable shield must be grounded at spacing between 15 to 22 m (50 to 75 ft). This is especially important on towers taller than 45 m (150 ft).

For roof installations, use the following additional criteria:

- The drop cable shield must be bonded to the building grounding system at its top entry point (usually on the roof).

- The drop cable shield must be bonded to the building grounding system at the entry point to the equipment room.

Lightning Surge Protection Units location

Lightning Surge Protection Units or Gigabit Surge Suppressors must be installed at two points on drop cables:

- There is room to mount the LPU, either on the ODU mounting bracket or on the mounting pole below the ODU.
- The drop cable length between the ODU and top LPU must not exceed 600 mm.
- There is access to a metal grounding point to allow the ODU and top LPU to be bonded in the following ways: top LPU to ODU; ODU to grounding system.

Find a location for the bottom LPU that meets the following requirements:

- The bottom LPU can be connected to the drop cable from the ODU.
- The bottom LPU is within 600 mm (24 in) of the point at which the drop cable enters the building, enclosure or equipment room within a larger building.
- The bottom LPU can be bonded to the grounding system.

Network Design Consideration

Golay Code assignment

Golay Code is used to prevent self-interference caused by early weak interference. For example, without Golay Code, a very weak signal can be picked up and processed by unwanted device. Golay Code encoded with frame preamble makes the signal undecodable by the unwanted target device, thus prevent the unwanted target device from processing the frame. The following diagram shows how Golay Code may help with preventing early weak interference.

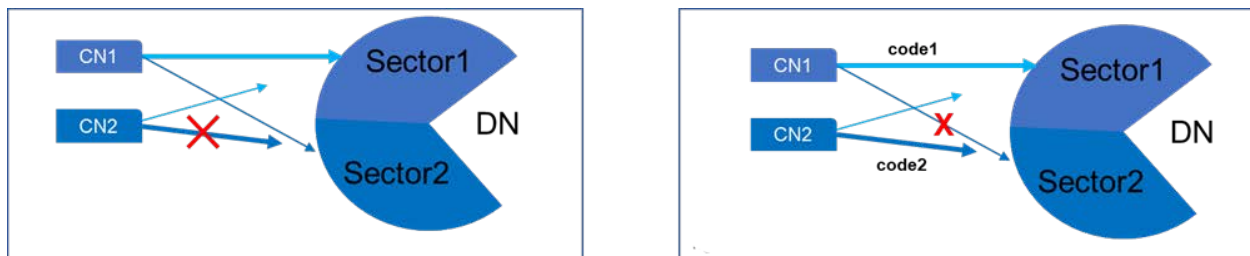

Figure 2: Signal from CN1 without Golay Code

The first figure shows that without Golay Code, signal from CN1, although value weak when received by Sector2 of the DN, will be processed, even though the signal is targeting only Sector1. Meanwhile, Sector2 ignores signal from CN2 because it sends the data a little bit later than CN1 because Sector2 is busy processing signal from CN1.

The second figure shows that because Sector1 and Sector2 use different Golay Code, the weak signal from CN1 (unwanted source for Sector2) will be rejected by Sector2 so signal from CN2 will be processed because Sector2 would not be busy processing CN1's signal.

The following are best practice for Golay code using in system design:

1. Use different Golay codes for each sector at the DN same location.
2. Use different Golay codes for nodes that are within short distance (usually two hops from each other) with opposite polarity.

The following diagram shows one example of proper Golay code configuration, with three Golay codes in use:

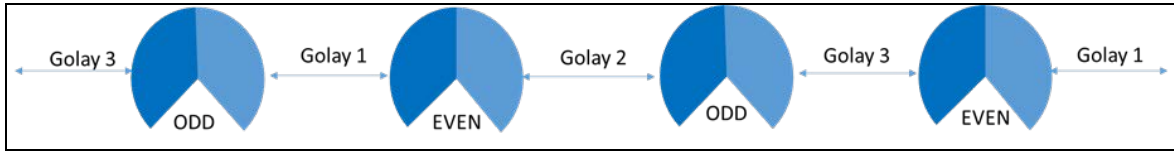

Angle separation

Suppose two CNs are connected to two different sectors of a DN. CN1 connects to Sector1 and CN2 connects to Sector2. If the angle separation of the CNs to the DN is smaller than 20 degree, it is very possible that the side lobe beam from Sector2 to CN2 will be received by CN1 which may cause high level of noise when CN1 is receiving data from Sector1. The solution to resolve this issue is to either have a higher angle separation, or have both CNs connect to the same sector.

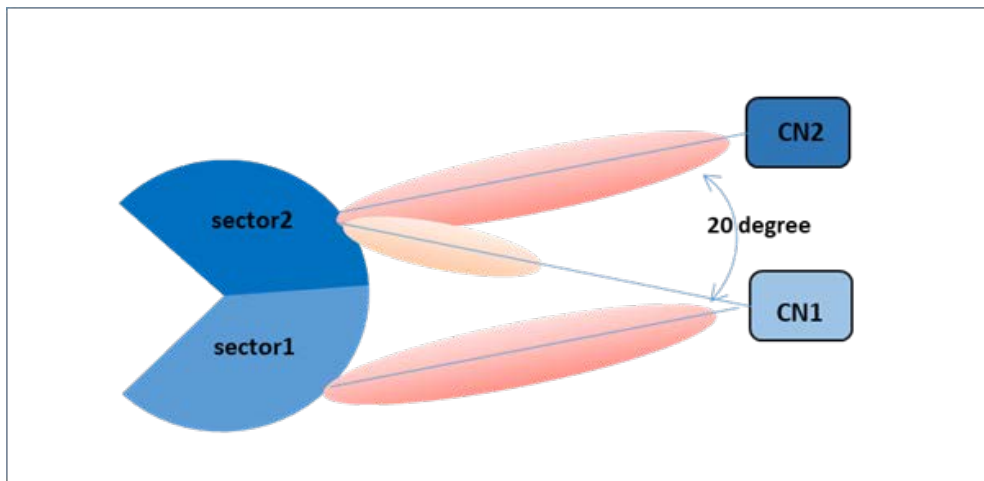

Avoid butterfly pattern

Consider two DNs next to each other, one in odd polarity and one in even polarity. When the odd DN is transmitting, to CN1, CN2 can be transmitting to the even DN. If the angle separation is too small (e.g. within +/- 10 degree), the side lobe for signal for CN1 can spill into the Even DN, thus causing very high level of noise, when the even DN is receiving data from CN2, which is in the same transmission cycle as the odd DN. This is called butterfly pattern and it should be avoided.

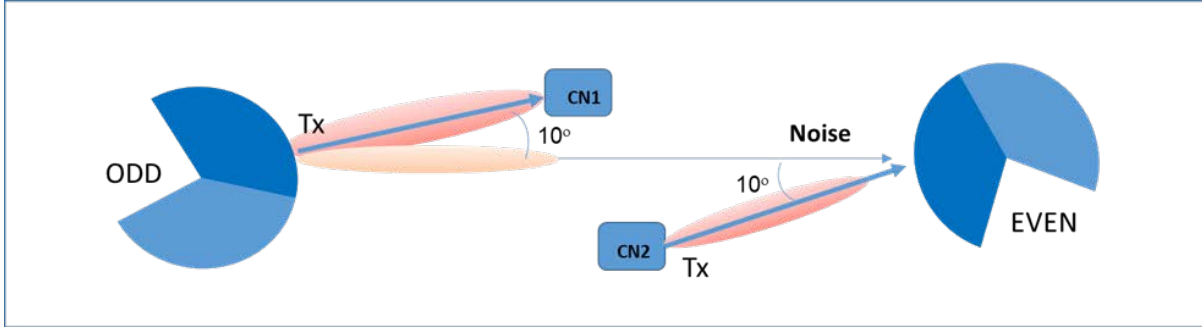

Near-Far ratio

cnWave supports adaptive transmission power control. When two radios are close to each other, the transmission power is adapted lower and when two radios are far from each other, the transmission power is adapted higher to accommodate optimal signal quality.

When two CNs are connected to two different sectors of a DN, if they do not have an angle separation of greater than 45 degree while the distance ratio between near-end CN to the DN and the far-end CN to the DN is less than 1/3, the side-lobe signal from Sector2 to CN2 is too strong for CN1, thus causing very high noise level on CN1 when it is receiving data from Sector1.

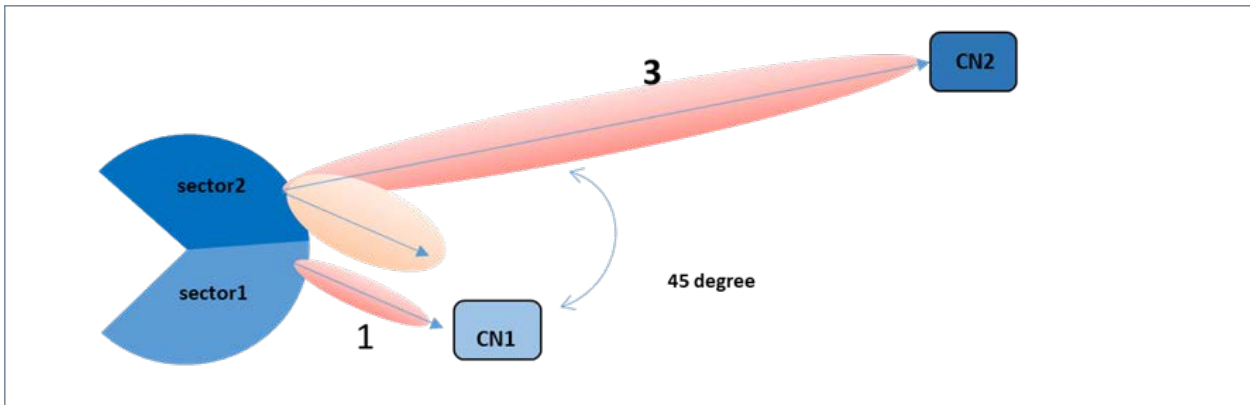

Y-Street avoidance

A DN with two peer DNs should be avoided in links that require high wireless capacity. The first few hops away from a PoP node should avoid the Y-street configuration. The following diagram shows two examples. On the top example, which is a bad one, the first hop DN from the PoP node is relayed by the same sector, which cut the end-to-end capacity by 50%.

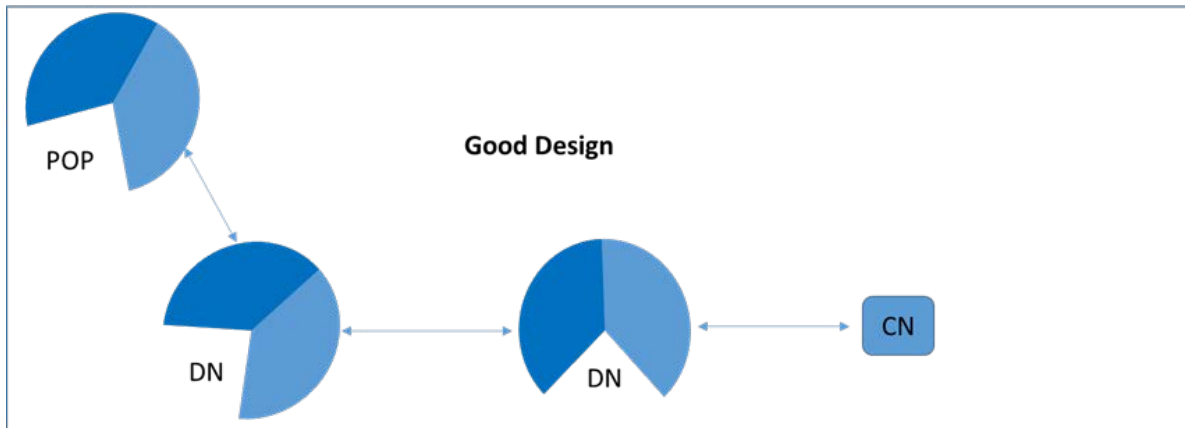
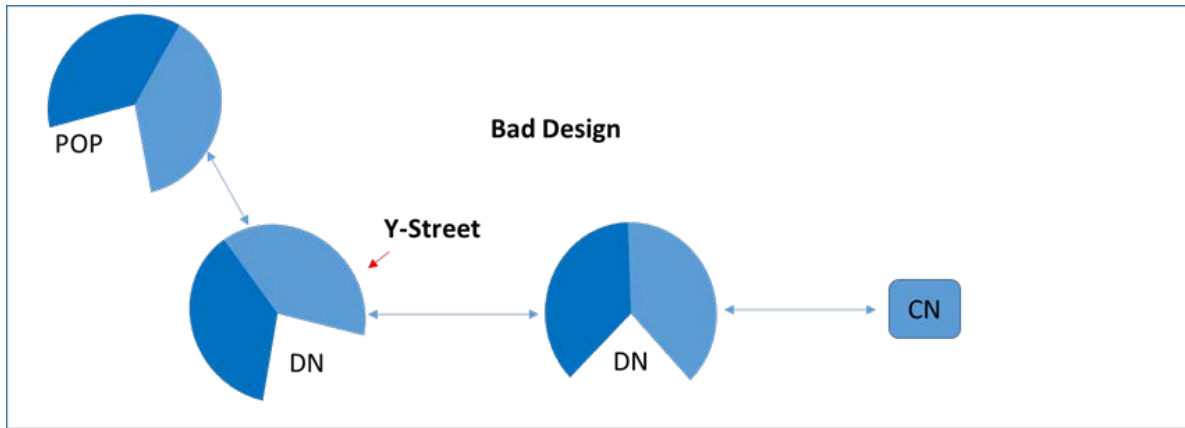

Radio spectrum planning

General wireless specifications

The following [60 GHz cnWave™ wireless specifications \(all variants\)](#) table lists the wireless specifications that apply to all 60 GHz cnWave™ frequency bands:

Table 25: 60 GHz cnWave™ wireless specifications (all variants)

Item	Specification
Channel selection	Open/R protocol or manual selection
Manual power control	Supports ATPC automatic transmit power control and maximum EIRP can be set lower than default power limit.
Integrated antenna type	<ul style="list-style-type: none"> V3000 44.5 dBi gain and 40.5 dBi gain V1000 22.5 dBi gain
Duplex schemes	Symmetric 50:50 fixed and asymmetric fixed
Range	100 m to 2 KMs, depends on the following factors: <ul style="list-style-type: none"> Frequency selected

Item	Specification
	<ul style="list-style-type: none"> • Rain condition • Availability • EIRP limitation
Over-the-air encryption	AES 128-bit
Weather sensitivity	Highly sensitive due to rain range conditions, For more information in range, refer Rain and attenuation table.

Regulatory limits

Many countries impose EIRP limits (allowed EIRP) on products operating in the bands used by the 60 GHz cnWave™ these are commonly identified by limitations on conducted transmit power or by antenna gain. For example:

Table 26:ERC recommendation (70-03)

Frequency Band		Power / Magnetic Field
c2	57 - 71 GHz	40 dBm E.I.R.P., 23 dBm/MHz E.I.R.P. density and maximum transmit power of 27 dBm at the antenna port / ports.
c3	57-71 GHz	55 dBm E.I.R.P., 38 dBm/MHz E.I.R.P. density and transmit antenna gain \geq 30 dBi.

CFR47 Part 15.255(c)(ii):

For fixed point-to-point transmitters located outdoors, the average power of any emission shall not exceed 82 dBm, and shall be reduced by 2 dB for every dB that the antenna gain is less than 51 dBi. The peak power of any emission shall not exceed 85 dBm, and shall be reduced by 2 dB for every dB that the antenna gain is less than 51 dBi.

Link planning

This section describes factors to be taken into account when planning links, such as range, obstacles path loss and throughput. It is highly recommended to use Cambium LINKPlanner software when planning the links.

LINKPlanner

The Cambium LINKPlanner software and user guide may be downloaded from the support website (see <https://support.cambiumnetworks.com/files/linkplanner/>).

LINKPlanner imports path profiles and predicts data rates and reliability over the path. It allows the system designer to try different antenna heights and RF power settings. It outputs an installation report that defines the parameters to be used for configuration, alignment and operation. Use the installation report to compare predicted and actual link performance.

Exclusion zones for the 59 – 63.9 GHz band

In the three geographical areas outlined in [59 - 63.9 GHz Transmission Exclusion Zones](#) no transmissions are permitted.

Table 27: 59 - 63.9 GHz transmission exclusion zones (UK IR 2078 Section 4 and IR 2030 IR2030/7/4 (2018/316/UK))

Site Name	Site Location	Radius of exclusion zone from the centre of site location
Site 1	07° 23' 36.6" W, 57° 21' 3.6" N	6 Km
Site 2	04° 58' 21" W, 51° 37' 16.8" N	6 Km
Site 3	00° 36' 22.8" W, 52° 38' 1.8" N	6 Km

Range and obstacles

Calculate the range of the link and identify any obstacles that may affect radio performance.

Perform a survey to identify all the obstructions (such as trees or buildings) in the path and to assess the risk of interference. This information is necessary in order to achieve an accurate link feasibility assessment. The 60 GHz cnWave™ radios are designed to operate in Line-of-Sight (LoS) environments.

The 60 GHz cnWave™ radios operate at ranges from 15 m (49 ft) to 2000 m (1.2 miles). Operation of the system depends on the frequency channel chosen.

Path loss

Path loss is the amount of attenuation the radio signal undergoes between the two ends of the link. The path loss is the sum of the attenuation of the path if there were no obstacles in the way (Free Space Path Loss), the attenuation caused by obstacles (Excess Path Loss) and a margin to allow for possible fading of the radio signal (Fade Margin). The following calculation needs to be performed to judge whether a particular link can be installed:

$$L_{free_space} + L_{excess} + L_{fade} + L_{seasonal} < L_{capability}$$

Where:	Is:
L_{free_space}	Free Space Path Loss (dB)
L_{excess}	Excess Path Loss (dB)
L_{fade}	Fade Margin Required (dB)
$L_{seasonal}$	Seasonal Fading (dB)
$L_{capability}$	Equipment Capability (dB)

At 60 GHz cnWave™ the oxygen absorption is a key component of the free space path loss and varies substantially depending on the frequency channel selected. Use LINKPlanner to calculate the oxygen absorption component for the required path and frequency channel.

Data network planning

This section describes factors to be considered when planning 60 GHz cnWave™ data networks.

60 GHz cnWave™ network can be deployed as point-to-point backhaul-bridge, Point-to-Multipoint coverage network and mesh network that provide network rebound. Regardless of the network topology, the underlining routing protocol between cnWave™ radios is always IPv6 with OpenR routing protocol.

By default, the cnWave™ operates in IPv6 layer 3 network mode, requiring IPv6 based routing gears and etc. While underlying routing in the cnWave™ network relies on IPv6 OpenR routing, the network can be designed to operate in pure IPv4 network mode, transporting layer two traffic (VLAN tagged and untagged) with GRE tunnels built-in by the system.

There is no fundamental difference between configurations of PTP vs. PMP vs. Mesh, because underlying routing mechanism of the cnWave™ network is always IPv6 based OpenR routing.

In a PTP network, you have one PoP DN and a CN to form a link. In a PMP network, you have one PoP DN and multiple CNs (up to 30 CNs if V5000 is used) to form a PMP cluster. You can have multiple PMP clusters to form a coverage area network.

User can have one PoP node with multiple DN or CNs. If DN are connected with each other, user gets a mesh network. User can them have multiple PoPs and DN and if the link with each other and form a complex mesh network.

Point to Point based single link Ethernet bridge

A Point to Point cnWave™ link can be configured to work like an Ethernet bridge. The operator needs to configure one end as PoP DN, and the other end as CN.

Enable Layer 2 Bridge. While the radios still runs on IPv6, the Layer 2 Bridge configuration allows user Layer 2 data (VLAN tagged and untagged) to be transmitted transparently through the link.

IPv6 address of the PoP and CN can be automatically generated and they do not need to be routable through the external network as long as the E2E is collocated with the PoP DN or within the same VLAN of the PoP DN. The operator can assign IPv4 address to the radios for management purpose.

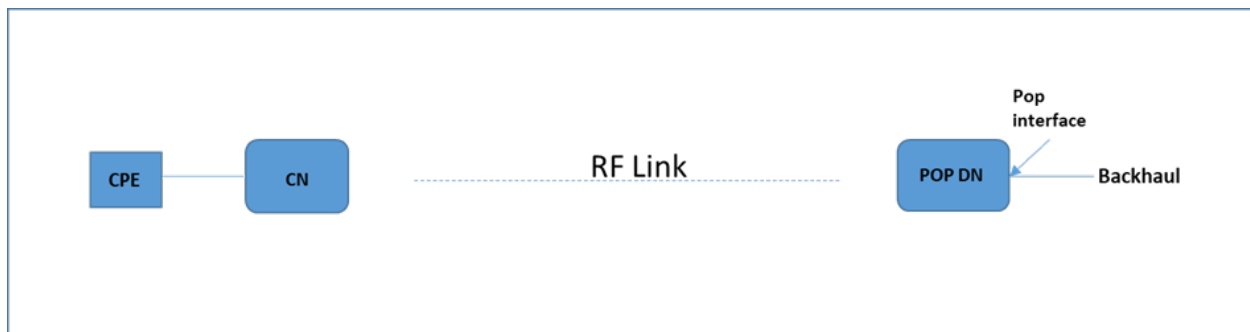

IPv4/L2 based PMP and mesh network planning

The operator can build a complete IPv4 based network without the need of any IPv6 routers. The following figure shows the network.

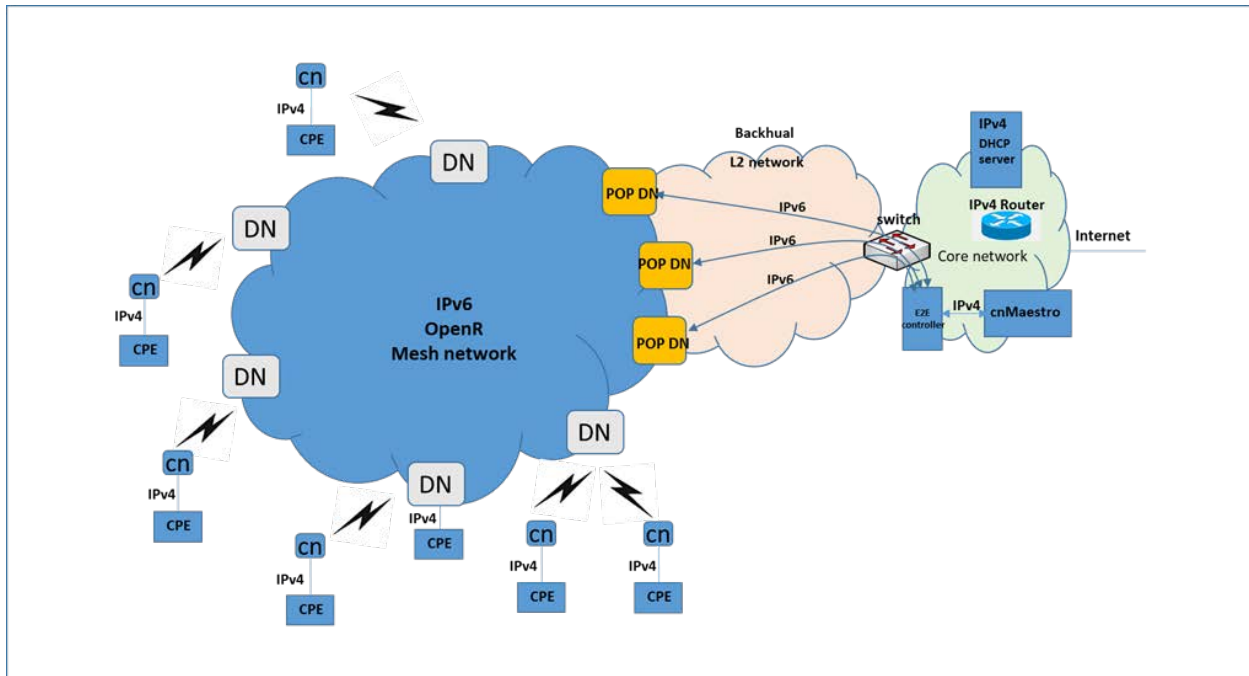

60 GHz cnWave™ IPv6 IP address is generated automatically by the system.

1. Single PoP, E2E resides in the PoP DN

When configuring the PoP E2E, the operator can configure the IPv6 address to be generated automatically.

2. Multiple PoPs, E2E controls all the PoPs

The cnMaestro generates the IPv6 configuration for all the PoPs. The user can download the config file from cnMaestro. This config file contains all the PoPs IPv6 configuration. The IPv6 configuration is associated with the MAC address of each PoP DN. When loading the config file to the PoP DN during initial configuration, the PoP DN chooses the IPv6 address by matching its MAC address, so there is no IPv6 address conflict.

The PoP DN's automatically uses the E2E controller as the default gateway of IPv6 traffic. Since IPv6 traffic is used only for management purpose, there may be no concern of overloading the E2E. (IPv6 payload traffic should be disabled in the radio configuration).

The E2E chooses any one of the active PoP DN as IPv6 default gateway. If the E2E detects that the default gateway PoP DN is down, it selects another PoP DN as default gateway.

Control traffic from E2E to all cnWave™ radios will be sent to the default gateway PoP, which relies on OpenR to route through correlated POP to the target radio.

Select the **Relay Port Interface** for the PoP DN's Ethernet interface for inter-PoPs OpenR routing to work.



Note

IPv6 routers in the network are not required. Ensure that the PoP DN's and the E2E be in the same VLAN.

Configure IPv4 address of the radios manually. The CPE IPv4 address can be manually configured or use DHCP server sitting in the core network. Depending on complexity of the network, IPv4 based router may be required to route the IPv4 traffic from the CPEs.

Mixture of IPv4 and IPv6 support

The operator can design the network so that both IPv4 and IPv6 user data are supported. In this case, IPv6 router is required at the core network. Ensure that if Layer 2 Bridge is enabled, by default all the user traffic including IPv6 is encapsulated in the GRE tunnel. The IPv6 user traffic is passed through the cnWave™ network in the GRE tunnel, so that it does not be routed by the cnWave™ radios, but rather by an external IPv6 router.

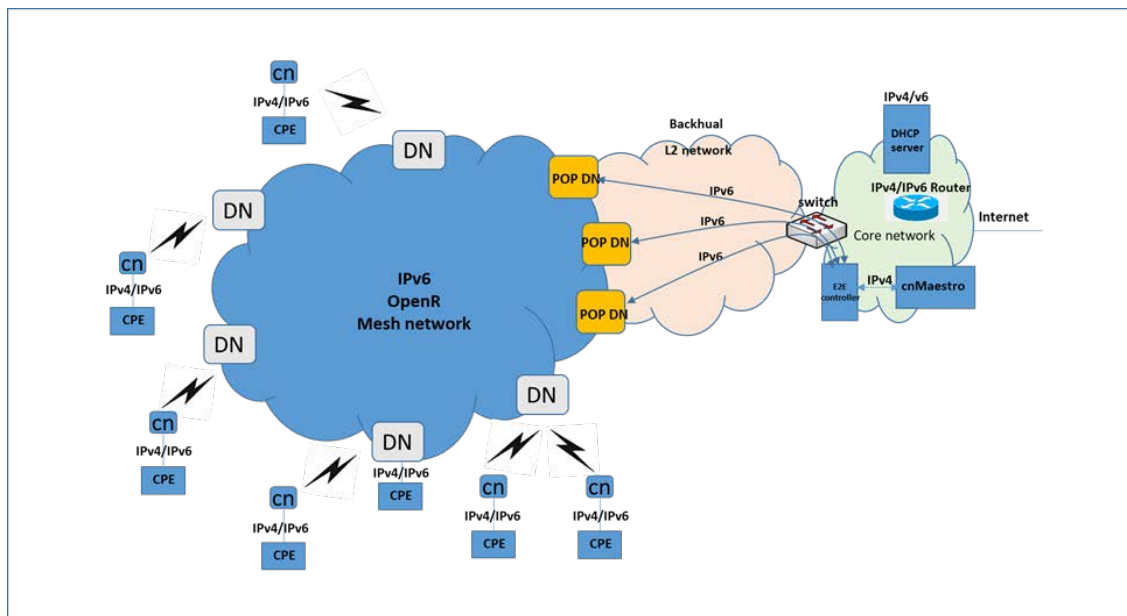

The operator can choose certain of the radio Ethernet port to be SLAAC based port or (CPE interface), user traffic from this port is only IPv6 based and does not be encapsulated into the GRE layer two bridge when transmitted over the wireless network. Although this reduces overhead, it is not recommended since this adds complexity to the network design (the operator may need to add a BGP router to the network).

IPv6 mode network planning

If the operator choose to have the network completely run on IPv6 mode, then GRE Layer 2 Bridge is not required and a BGP router is usually required to route traffic between the wireless network and the external network.

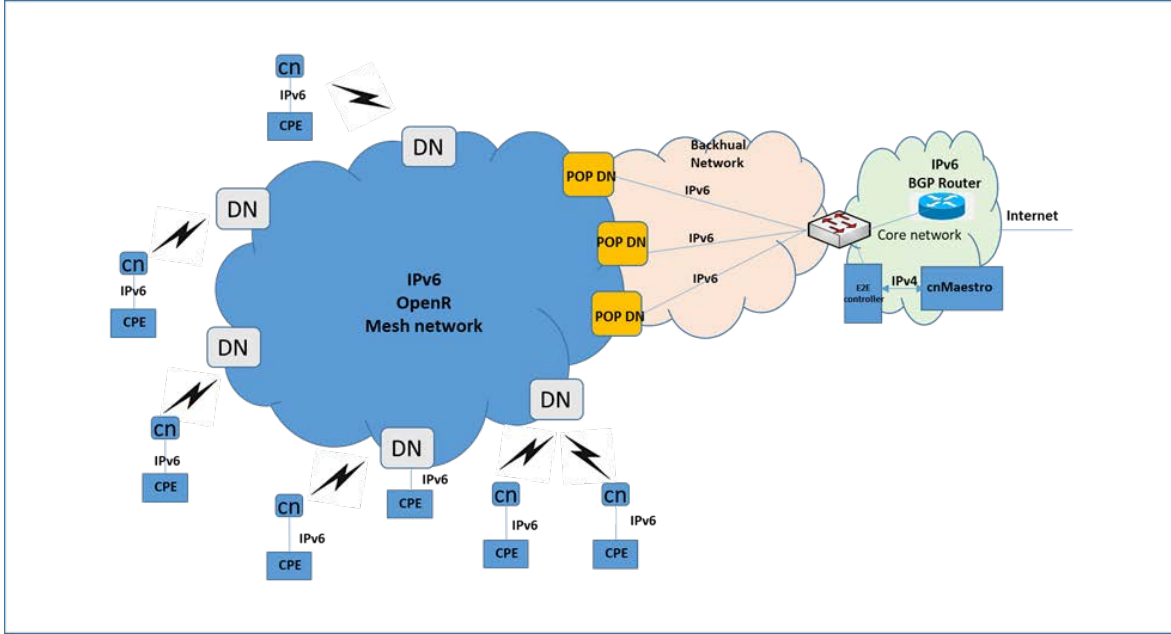

IPv6 network design consideration

There are two sets of the networks while designing the IPv6 network. one set is for the OpenR subnets (e.g. prefix of 56 bits and partition into multiple 64 bits subnet). Each cnWave™ node is assigned with a subnet.

Each PoP node, on the other hand, besides being part of the OpenR mesh network and has a subnet assigned to it, and also have an IPv6 address assigned to it, as PoP interface IPv6 address.

If the operator let the system automatically generates IP address configuration, the IP address always be in the format of FD00:xxxxxx, which is standard routable private IPv6 address.

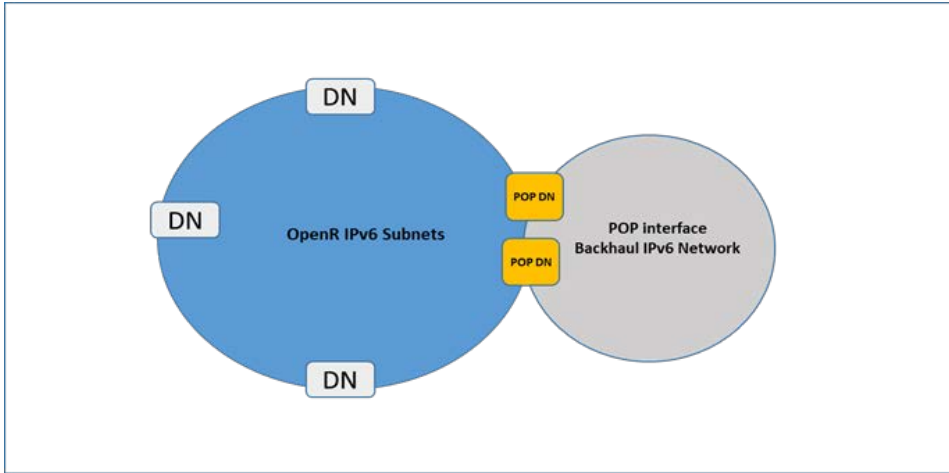

Reserved IPv6 address space

If the operator let the system automatically generate the IPv6 addresses for the network, the following private IPv6 address spaces are reserved:

- FD00:CEED::0/32 for seed prefix of the mesh network
- FD00:BA5E::0/32 for all the PoP nodes and the E2E Controller

E2E and cnMaestro deployment consideration

While the E2E and cnMaestro are two separate entities, they can be hosted on separate computers or same computer. While the E2E communicates with the cnMaestro using IPv4, the E2E communicates with the cnWave™ radios using IPv6.

Ethernet bridging/IP routing

Layer2 Bridging

L2 Bridge employs Ethernet over GRE (EoGRE) to carry the customer traffic across the Terragraph network. When L2 Bridge is enabled, all CNs and DNs automatically create an EoGRE tunnel with their PoP node and the PoP node creates a tunnel back to each of those CNs/DNs. The tunnel is capable of carrying both IPv4 and IPv6 customer traffic between CN and PoP. The IPv6 over tunnel can be optionally disabled from the UI.

Broadcast/Multicast control

Downstream broadcast can be controlled by explicitly disabling it from the UI. Disabling IPv6 over tunnel also reduces the downstream multicast traffic.

Limitations

- In bridge mode, the V5000 PoP node can forward 2.6 Gbps of TCP traffic and 1.5 Gbps UDP traffic in the down-link direction.

Layer 2 Bridge support in Multi-PoP deployments



Note

Multi-PoP deployment is not recommended if on board E2E is enabled.

This feature is applicable to Layer 2 bridging and Deterministic Prefix Allocation (DPA) are configured to be used in the network.

In Terragraph network, CNs and DNs are allocated prefixes from a seed prefix. There are various ways for allocating prefix. In DPA, controller assigns prefix zones to PoPs based on the network topology to allow PoP nodes to take advantage of summarizing the route and helps in load balancing ingress traffic.

CNs and DNs get prefixes from the respective PoP zone which is allocated by the controller. CNs and DNs see multiple PoP nodes in mesh, they select PoP to form GRE tunnel, by matching their local IPv6 address with PoPs local IPv6 address. The longest prefix match is selected as best PoP for L2 GRE Tunnel establishment. Multi-PoP setup gives the advantage that user data traffic can take alternate routes if the best route is unavailable for some reason. Open/R make this selection to route the traffic. If PoP is unavailable, CNs and DNs switch to next best PoP. They however keep track of their primary PoP availability and switch to it once it becomes online.

External Layer 2 Concentrator support

External device can be used as a L2 GRE Concentrator. In large mesh, it is advisable to use an external device as a L2 GRE concentrator. Concentrator could be a Linux server or any router or switch supporting

IPv6 L2 GRE tunnels. e.g: Juniper MX 100.

Select **Static** tunnel concentrator option and provide IPv6 address to configure external concentrator IPv6 address.

Layer 2 Bridge

Enable Layer 2 bridge
By selecting this checkbox, you will be enabling Layer 2 network bridging (via automatically created tunnels) across all nodes connected to a PoP. This will facilitate bridging of IPv4 traffic across the wireless networks.

Tunnel Concentrator
 Best PoP Static

Tunnel Concentrator IPv6 Address

Concentrator can be a PoP device or an external switch/router

Multi-PoP deployments

The following aspects must be taken care in cnWave Multi-PoP deployments:

- [Layer 2 domain](#)
- [Open/R on the PoP interface port](#)
- [MTU of upstream switch ports](#)
- [Prefix allocation](#)

Layer 2 domain

All cnWave PoP nodes must be connected to the same Layer 2 broadcast domain. PoP nodes learn about other PoP nodes using IPv6 multicast packets, which does not cross broadcast domain.

This allows cnWave PoP nodes to forward traffic to other cnWave PoP nodes via a wired connection when the routing path of the other PoP node is closer to the traffic's destination. This concept is called **Tromboning**, as the traffic enters in one PoP node and then leaves towards another PoP node.

Open/R on the PoP interface port

PoP interface port must be configured to run Open/R protocol. To enable this option, select **Multi PoP/ Relay port**.

Multi-PoP / Relay Port Interface

Aux Main SFP Disabled

Wired interfaces on which OpenR is run. Should be used when DNs are connected back to back and on PoPs in a multi PoP network.

MTU of upstream switch ports

PoP ports use a 2000 MTU size. So, all the switch ports must be at least 2000 MTU size. Even if the user traffic is limited to 1500 sized packets, switch ports should allow the higher MTU size. The following packets exchanged between the PoPs that can be of higher size:

- Open/R packets
- L2GRE packets (in Layer 2 mode)
- Software download packets.

Prefix allocation

It is recommended to select **Deterministic Prefix Allocation** option for Multi-PoP deployments

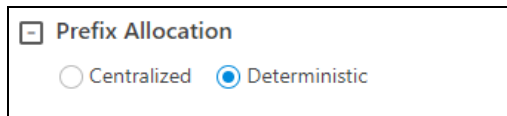

Layer two control protocols

60 GHz cnWave™ identifies layer two control protocols (L2CPs) from the Ethernet destination address or Ethertype of bridged frames. The QoS classification can be separately configured for these protocols.

Ethernet port allocation

The user has to decide how the three ODU Ethernet ports is allocated to the data service, management service and Local Management Service based on the following rules:

- Map the Data Service to at least one of the available wired Ethernet ports
- Map the Management Service to In-Band, or to any combination of the remaining unused Ethernet ports. If the Management Service is mapped to In-Band, it shares all of the ports selected for the Data Service. The Management Service can be disabled by mapping to None
- Map the Local Management Service to any combination of the remaining unused Ethernet ports. The Local Management Service can be disabled by mapping to "None".

The LAN configuration page ensures that the management agent can always be reached using either the management service or the local management service.

IP interface

Select the IP version for the IP interface of the ODU management agent. 60 GHz cnWave™ can operate in IPv4 mode (via L2 tunneling), IPv6 mode. Choose one IPv4 address and/or one IPv6 address for the IP interface of the ODU management agent. The IP address or addresses must be unique and valid for the connected network segment and VLAN.

Find out the correct subnet mask (IPv4) or prefix length (IPv6) and gateway IP address for this network segment and VLAN.

Ensure that the design of the data network permits bidirectional routing of IP datagrams between network management systems and the ODUs. For example, ensure that the gateway IP address identifies a router or other gateway that provides access to the rest of the data network

Daisy-chaining 60 GHz links

When connecting two or more 60 GHz cnWave™ links together in a network (daisy-chaining), do not install direct copper CAT5e connections between the PSUs. Each PSU must be connected to the network terminating equipment using the LAN port. To daisy-chain 60 GHz cnWave™ links, install each ODU-to-ODU link using one of the following solutions:

- A copper CAT5e connection between the Aux ports of two ODUs.
- A copper CAT5e connection between the Aux port of one ODU and the SFP port of the next ODU (using a copper SFP module).
- Optical connections between the ODUs (SFP ports) using optical SFP modules at each ODU.

Chapter 5: Installation

Safety



Warning

To prevent loss of life or physical injury, observe the following safety guidelines. In no event shall Cambium Networks be liable for any injury or damage caused during the installation of the Cambium 60 GHz cnWave™ radio nodes. Ensure that only qualified personnel install 60 GHz cnWave™ radios.



Attention

Pour éviter toute perte de vie ou blessure physique, respectez les consignes de sécurité suivantes. En aucun cas Cambium Networks ne pourra être tenu responsable des blessures ou dommages causés lors de l'installation des nœuds radio Cambium 60 GHz cnWave™. Assurez-vous que seul du personnel qualifié installe les radios cnWave™ 60 GHz.

Power lines

Exercise extreme care when working near power lines.

Working at heights

Exercise extreme care when working at heights.

PSU

Always use one of the approved power supply options. Failure to use the Cambium supplied PSUs could result in equipment damage and will invalidate the safety certification and may cause a safety hazard.

Grounding and protective earth

The cnWave radios must be properly grounded to protect against lightning. It is the user's responsibility to install the equipment in accordance with national regulations. In the USA follow the requirements of the National Electrical code NFPA 70-2005 and 780-2004 *Installation of Lightning Protection Systems*. In Canada, follow Section 54 of the *Canadian Electrical Code*. These codes describe correct installation procedures for grounding the outdoor unit, mast, lead-in wire and discharge unit, size of grounding conductors and connection requirements for grounding electrodes. Other regulations may apply in different countries and therefore it is recommended that installation of the outdoor unit be contracted to a professional installer.

AC supply

Always use an appropriately rated and approved AC supply cord-set in accordance with the regulations of the country of use.

Powering down before servicing

Before servicing 60 GHz cnWave™ equipment, always switch off the power supply and unplug it from the PSU.

Do not disconnect the RJ45 drop cable connectors from the radio while the PSU is connected to the power supply. Always remove the AC or DC input power from the PSU.

Primary disconnect device

The primary disconnect device is the main power supply.

External cables

Safety may be compromised if outdoor rated cables are not used for connections that is exposed to the outdoor environment.

Drop cable tester

The PSU output voltage may be hazardous in some conditions e.g: wet weather. Do not connect a drop cable tester to the PSU, either directly or via LPU's.

RF exposure near the antenna

Strong Radio Frequency (RF) fields is present close to the antenna when the transmitter is ON. Always turn off the power to the radio before undertaking maintenance activities in front of the antenna.

Minimum separation distances

Ensure that personnel is not exposed to unsafe levels of RF energy. The units start to radiate RF energy as soon as they are powered up. Never work in front of the antenna when the radio is powered. Install the radios so as to provide and maintain the minimum separation distances from all persons. For minimum separation distances, see [Calculated distances and power compliance margins](#).

Grounding and lightning protection requirements

Ensure that the installation meets the requirements defined in [Installation](#) section.

Grounding cable installation methods

To provide effective protection against lightning induced surges, observe these requirements:

- Grounding conductor runs are as short, straight and smooth as possible, with bends and curves kept to a minimum.
- Grounding cables must not be installed with drip loops.
- All bends must have a minimum radius of 200 mm (8 in) and a minimum angle of 90°. A diagonal run is preferable to a bend, even though it does not follow the contour or run parallel to the supporting structure.
- All bends, curves and connections must be routed towards the grounding electrode system, ground rod / ground bar.
- Grounding conductors must be securely fastened.

- Braided grounding conductors must not be used.
- Approved bonding techniques must be used for the connection of dissimilar metals.

Siting radios

Radios are not designed to survive direct lightning strikes. For this reason they must be installed in Zone B as defined in *Lightning protection zones*. Mounting in Zone A may put equipment, structures and life at risk.

60 GHz cnWave™ radios and mounting bracket options

Mounting bracket options

The 60 GHz cnWave™ series supports eight mounting bracket options. Select the optimum mounting bracket arrangement based on the ODU type and the choice of wall or pole mounting. The wall mount plate for V1000 and V5000 are included with the ODU. Order the remaining brackets separately.

Table 28:ODU mounting bracket part numbers

Bracket	Pole diameter	ODU variants	Bracket part number
V1000 pole mount	40 mm to 77 mm (1.6 inches to 3.0 inches)	V1000	Included with V1000
V1000 wall mount	Wall mount	V1000	Included with V1000
V1000 adjustable pole mount	40 mm to 77 mm (1.6 inches to 3.0 inches)	V1000	N000900L022A
V3000 precision bracket	25 mm to 77 mm (1.0 inches to 3.0 inches)	V3000	C000000L125A
V3000 tilt bracket assembly	40 mm to 77 mm (1.6 inches to 3.0 inches)	V3000, V5000	N000045L002A
V3000 tilt bracket assembly with band clamps	90 mm to 230 mm (3.6 inches to 9.0 inches)	V3000, V5000	N000045L002A + third-party band clamps
V5000 pole mount	25 mm to 77 mm (1.0 inches to 3.0 inches)	V5000	C000000L137A
V5000 wall mount	Wall mount	V5000	C000000L136A

Installing the cnWave radio nodes

To install the radio, use the following procedure and guidelines:

1. [Typical installation](#)
2. [ODU interface with LPU on the poll](#)
3. [SFP and Aux Ethernet interfaces](#)
4. [Attach ground cables to the radio](#)
5. [Mounting the ODU on the mast or wall](#)

Typical installation

V1000

[V1000 typical installation](#) figure shows typical installation of cnWave CN on a mast and powered through PoE Power Injector.

1. Use recommended grounding and Surge Suppressor connections.
2. Use recommended cables for interfacing ODU (refer [Power supply and cable lengths supported](#) section).
3. Always install ODU 0.5 meters below the tip of the pole.

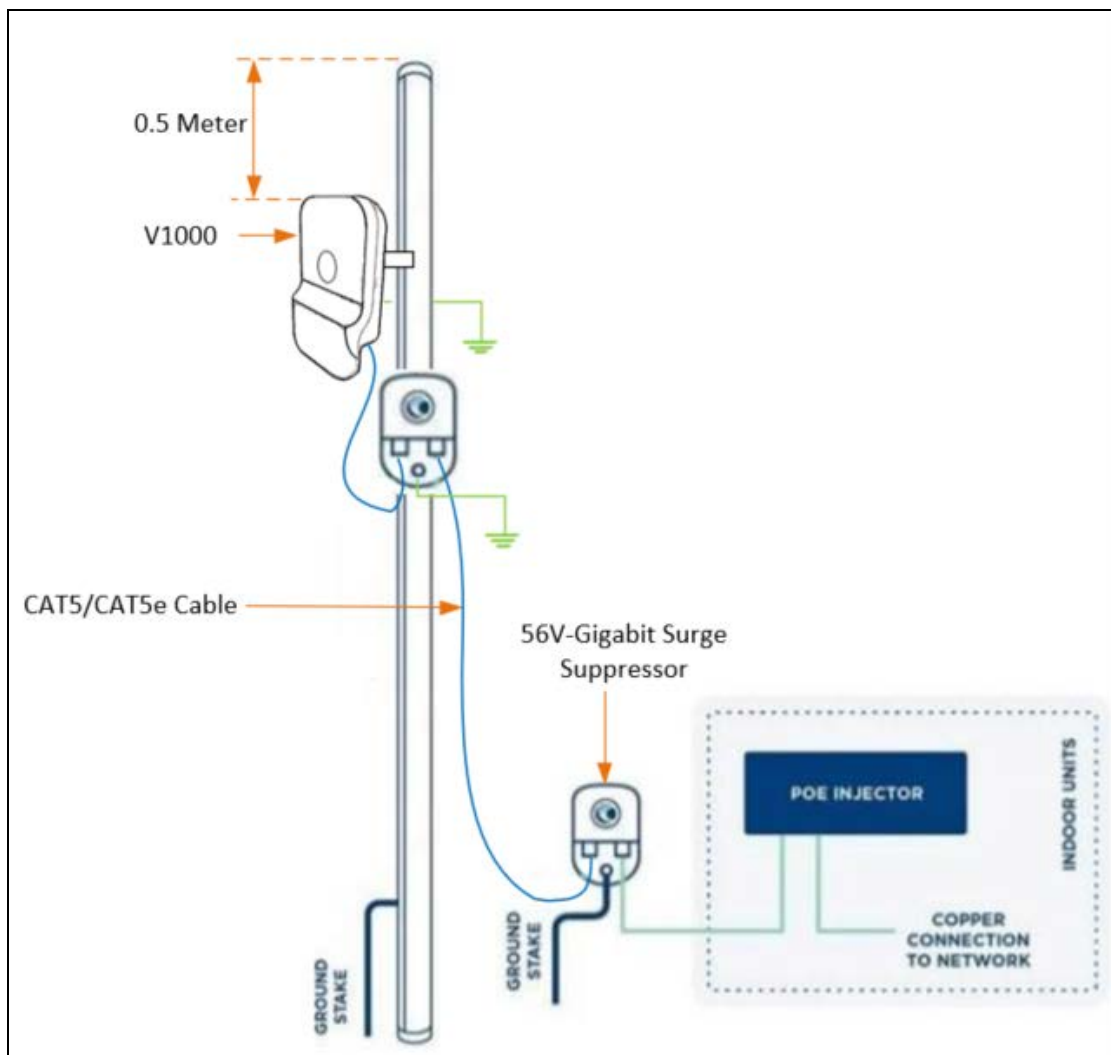

Figure 1: V1000 typical installation

V3000

[V3000 typical installation](#) figure shows typical installation of cnWave DN on a mast and powered through outdoor AC/DC PSU.

1. Use recommended grounding and LPU connections.
2. Use recommended cables for interfacing ODU (refer [Power supply and cable lengths supported](#) section).
3. Always install ODU 0.5 meters below the tip of the pole.

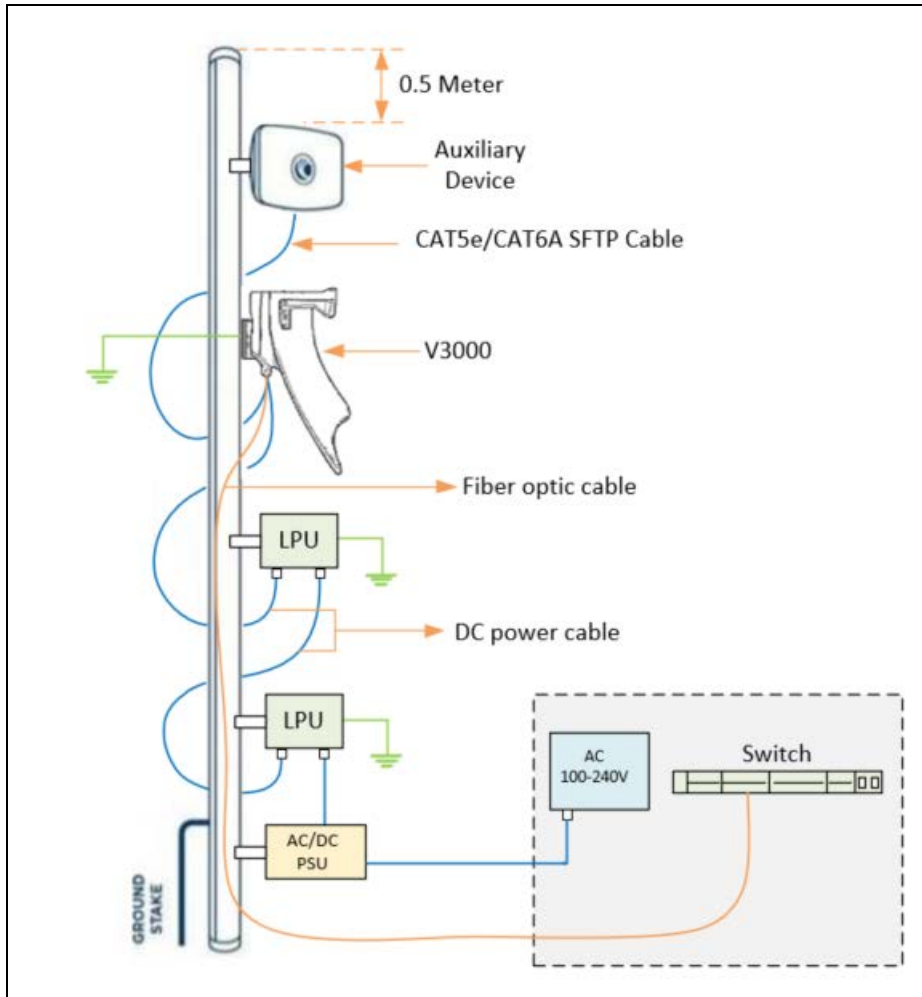

Figure 2: V3000 typical installation

V5000

[V5000 typical installation](#) figure shows typical installation of cnWave DN on a mast and powered through outdoor AC/DC PSU.

1. Use recommended grounding and LPU connections.
2. Use recommended cables for interfacing ODU (refer [Power supply and cable lengths supported](#) section).
3. Always install ODU 0.5 meters below the tip of the pole.

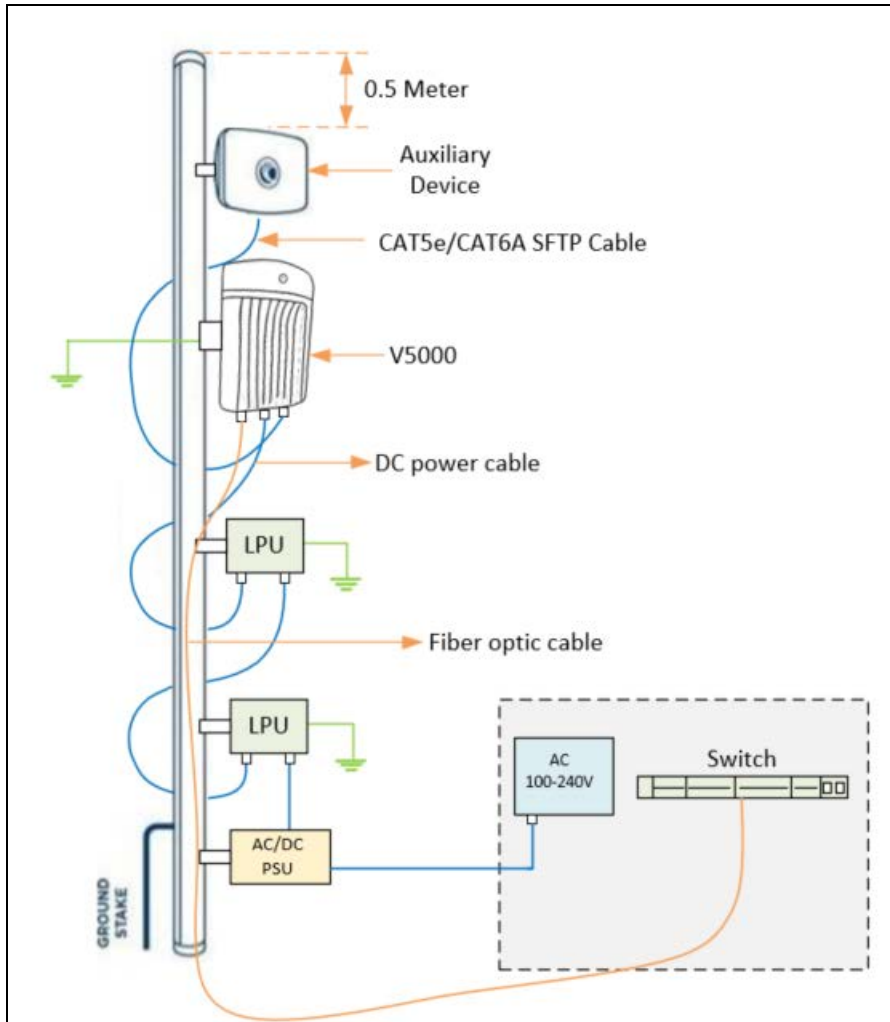

Figure 3: V5000 typical installation

ODU interface with LPU on the poll

[Installing V1000 on the pole](#) below shows steps show installation of V1000 CN on pole. Use 56V Gigabit Surge Suppressor for lightning protection. Ensure that the cable glands and grounding connections are made as per the diagram.

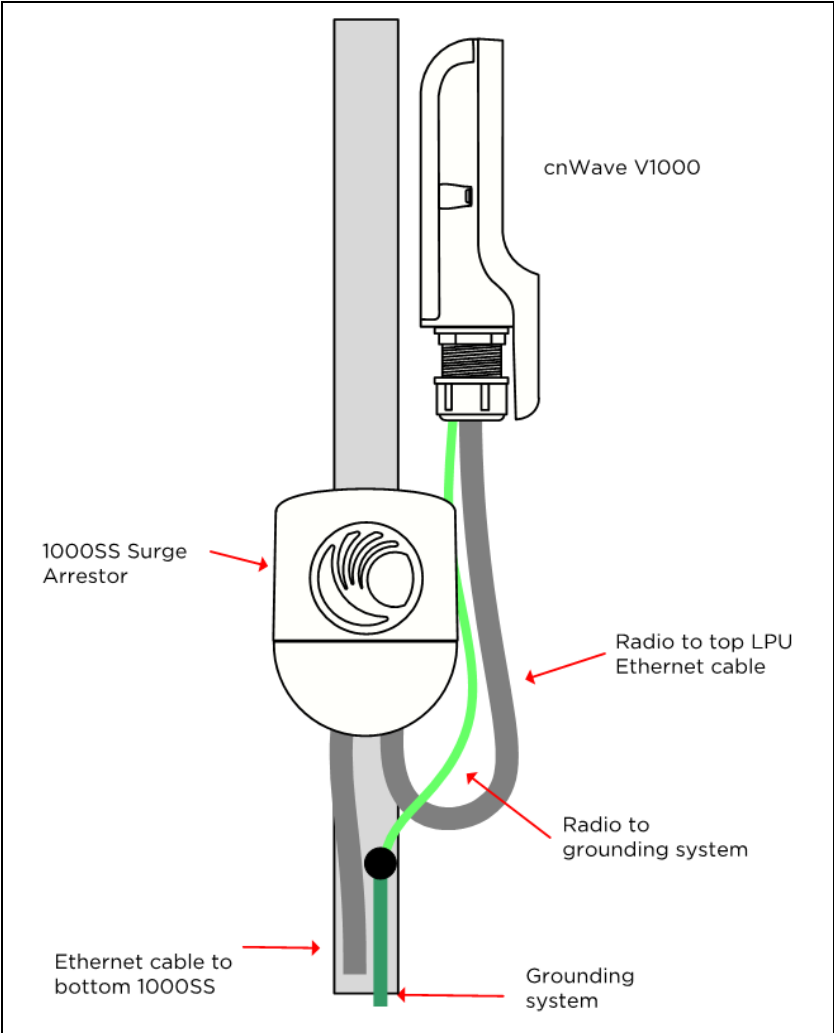

Figure 4: Installing V1000 on the pole

[Installing V3000 on the pole](#) shows installation of V3000 CN on a pole using a precision bracket. Use a recommended LPU for surge protection. Ensure glands and grounding connections are made as like the following image.

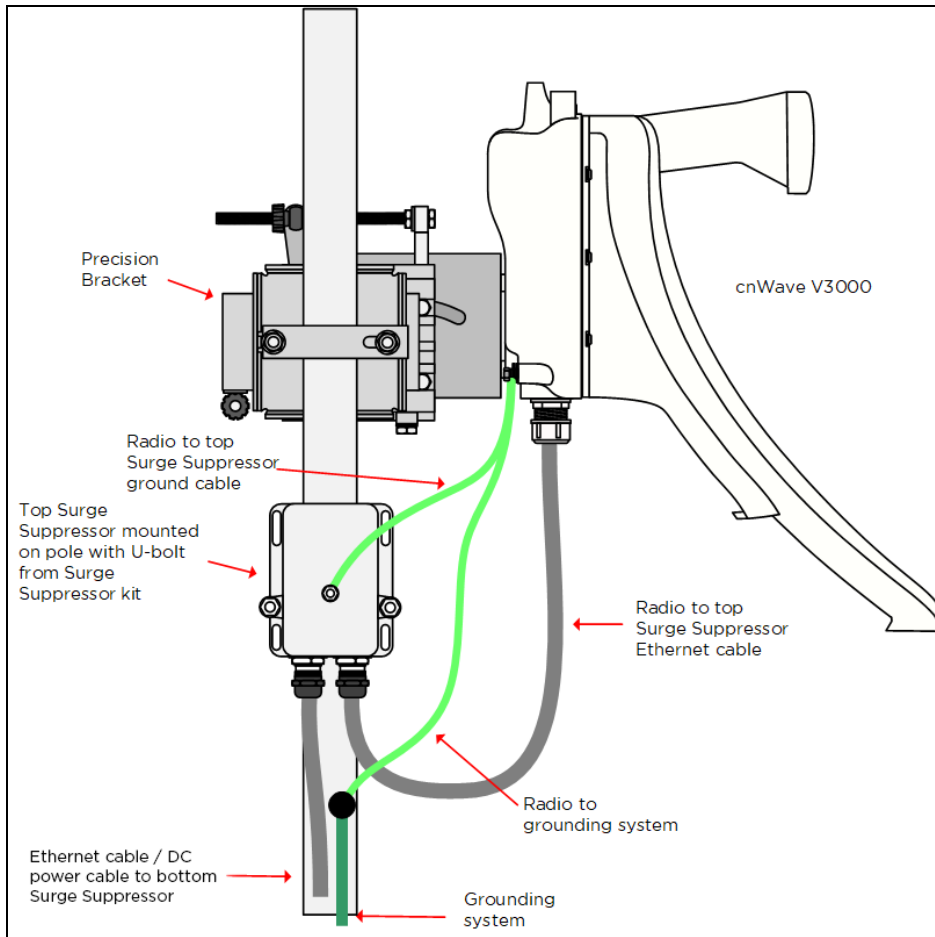

Figure 5: Installing V3000 on the pole

[Installing V5000 on the pole](#) shows installation of V5000 DN on a pole using a tilt bracket. Use a recommended LPU for surge protection. Ensure glands and grounding connections are made as like the following image.

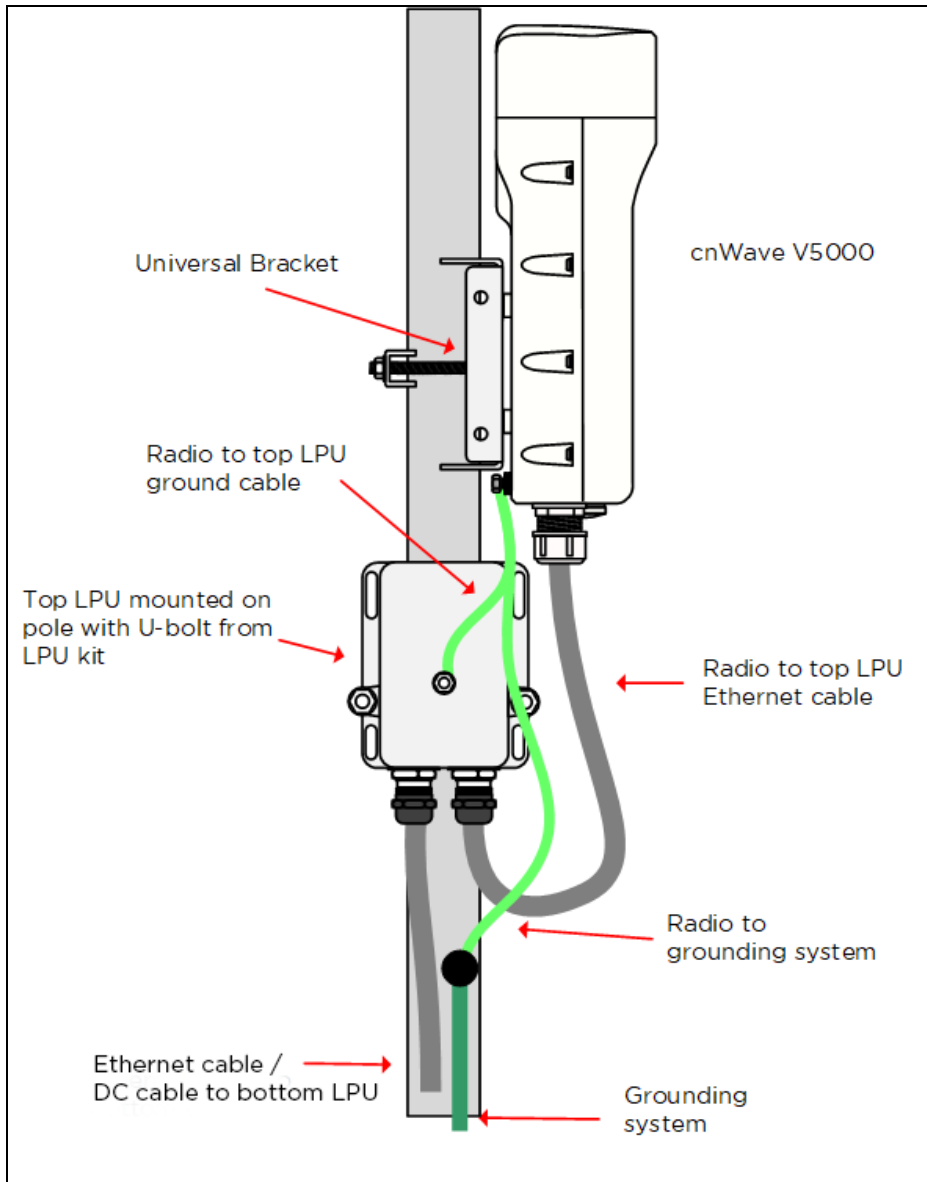

Figure 6: Installing V5000 on the pole

Attach ground cables to the radio

1. Fasten the ground cable to the radio grounding point using the M6 lug.



2. Tighten the ODU grounding bolt to a torque of 5 Nm (3.9 lb ft).

Mounting the ODU on the mast or wall

Select the most appropriate bracket mounting arrangement from the options listed in [Mounting bracket options](#). Refer to individual procedures below for each of the options:

- [V1000 pole mount](#)
- [V1000 wall mount](#)
- [V1000 adjustable pole mount](#)
- [V3000 precision bracket](#)
- [V3000 tilt bracket assembly](#)
- [V3000 tilt bracket assembly with band clamps](#)
- [V5000 pole mount bracket](#)
- [V5000 wall mount bracket](#)

V1000 pole mount

The V1000 CN can be installed to a pole using the supplied mounting plate and jubilee clip. Follow the below instructions to mount V1000 to the pole:

1. Insert the hose clamps through mounting plate and clamp to the pole by applying 3.0 Nm torque.

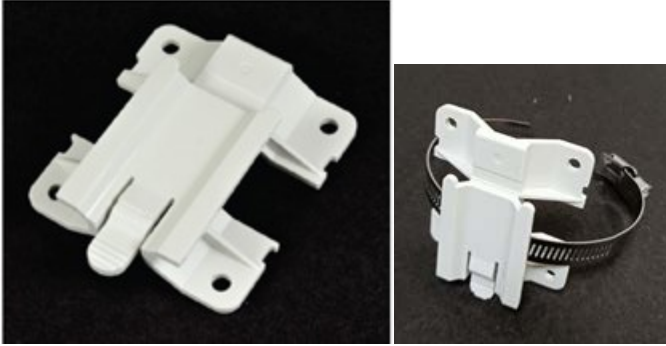

2. Insert the radio into the mounting plate on the pole.



V1000 wall mount

Follow the below instructions to mount V1000 to the wall:

1. Fix the mounting plate (supplied with the V1000 ODU) securely to a vertical wall, using suitable fixings.



Note

Fixing hardware is not supplied with the V1000.

2. Slide the V1000 ODU onto the mounting plate from above, ensuring that the spring clip in the mounting plate clicks into place on the radio.

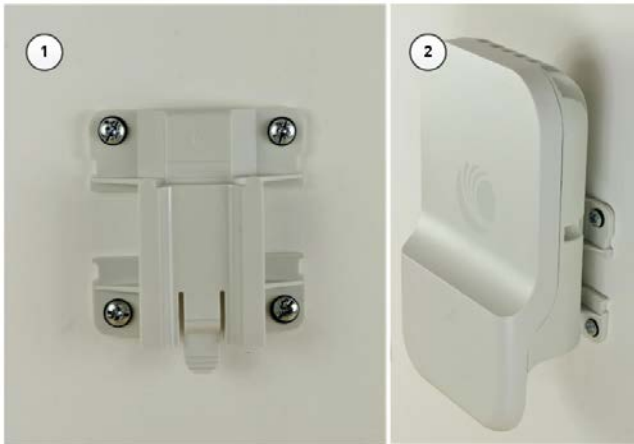

V1000 adjustable pole mount

Follow the below instructions to mount V1000 to the adjustable pole:

1. Insert the hose clamps through adjustable pole mount bracket and clamp to the pole by applying 3.0 Nm torque.

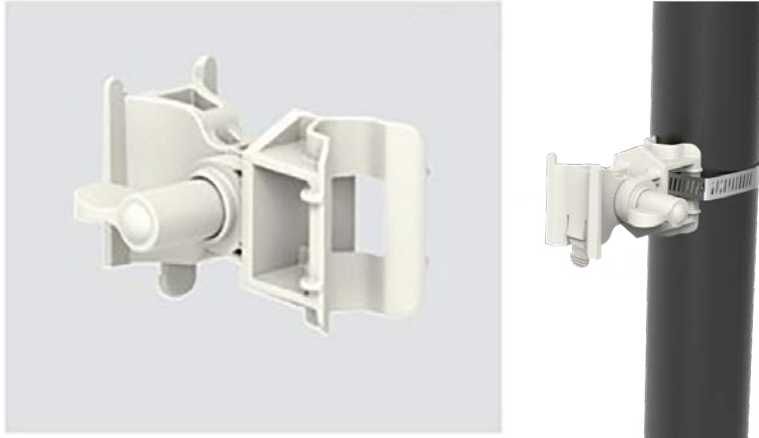

2. Insert the radio into the adjustable pole mount bracket on the pole.



V1000 alignment

The V1000 CN requires minimal effort to align as the internal antenna can beam steer ± 45 degrees in azimuth and ± 20 degrees in elevation from boresight. As long as the unit is installed with the remote node visible within this range, no further adjustment is required.

V3000 precision bracket

The precision bracket is used to mount the cnWave V3000 CN on a vertical pole, providing fine adjustment up to 18° in azimuth and $\pm 30^\circ$ in elevation for accurate alignment of the V3000. The precision bracket is compatible with pole diameters in the range 25 mm to 80 mm (1.0 inches to 3.1 inches).

These instructions illustrate the procedure for assembling and using the precision bracket. The mounting of the optional alignment telescope also explained.



1. Insert two of the long (120 mm) screws through the azimuth arm and the bracket body. The screws locate in the slots in the azimuth arm.



2. Fit two flanged M8 nuts to the long screws on the back of the bracket. Tighten using a 13 mm spanner.



3. Insert the three medium length (40 mm) M8 screws through the bracket base and the V3000 mount. The screws locate in the slots in the bracket base.



Ensure that the pivot pin in the elevation adjuster is located in the circular hole in the V3000 mount.



4. Fit plain washers and M8 Nyloc nuts to the screws on the back of the bracket base. Tighten using a 13 mm spanner.



5. Insert the two remaining long (120 mm) M8 screws through the bracket body and the azimuth arm. The screws locate in the slots in the bracket body.

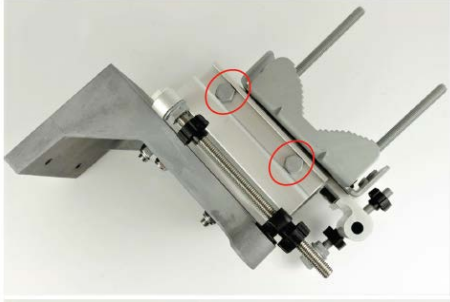

Ensure that the pivot pin in the azimuth adjuster is located in the circular hole in the bracket body.



6. Fit three sets of spacers, plain washers and M8 Nyloc nuts to the screws on the underside of the bracket base. Tighten using a 13 mm spanner.



7. Attach the V3000 mount to the radio using the four short M6 bolts. Tighten the four bolts to a torque setting of 5.0 Nm (3.7 lb ft) using a 13 mm spanner or socket.



8. Attach the precision bracket to the pole using the clamp and the remaining flanged nuts. Adjust azimuth approximately and tighten the nuts to 10 Nm (7.4 lbft) using a 13 mm spanner.



9. Lock the antenna alignment by tightening the five nyloc nuts (see [step 5](#) and [step 8](#)) to 10 Nm (7.4 lbft) using a 13 mm spanner or socket.



Precision bracket alignment

1. Ensure that the three Nyloc screws for securing the bracket in elevation are loose and the fine elevation adjuster is holding the weight of the unit.

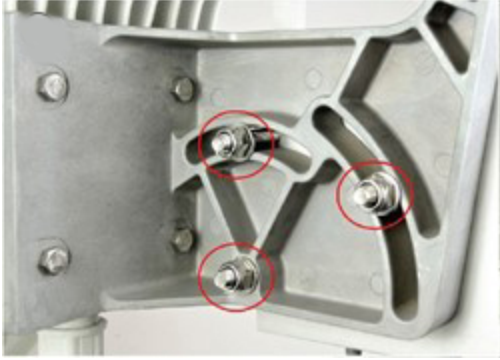

2. Ensure the two Nyloc screws for securing the bracket in azimuth are loose.



3. Before starting the mechanical alignment, move the fine elevation adjuster $2/3$ of the way across the screw until the unit is sitting at approximately 0 degrees in elevation.



4. Move the fine azimuth adjuster to approximately the centre of the available range and lock in position.



5. Loosen the clamp which attaches the bracket to the pole until there is enough freedom to rotate the unit in azimuth.
6. From behind the unit, using the sight to aim towards the remote node, rotate the unit until it is approximately aligned in azimuth. Tighten the clamp.
7. While looking for the far node through the site, rotate the fine elevation adjuster until the alignment is complete in the elevation plane. One turn of the adjustment wheel is equivalent to approximately one degree of elevation. Lock the fine elevation adjuster screws in place.



8. While looking for the far node through the site, rotate the fine azimuth adjuster until the alignment is complete in the azimuth plane. One turn of the adjustment wheel is equivalent to approximately one degree of azimuth. Lock the fine azimuth adjuster screws in place.
9. Make any remaining adjustments to the elevation and azimuth as required. Once complete, tighten the three Nyloc screws in place to fix the elevation alignment and do the same for the two Nyloc screws for azimuth alignment to 10 Nm (7.4 lbft) using a 13 mm spanner or socket.

Precision bracket alignment - optional telescope

1. Attach the telescope mount to the V3000 radio using the knurled screw.
2. Attach the telescope by looping the two elastic O-rings over the ears of the mount, ensuring that the telescope is located securely in the mount.



3. If a telescope with a smaller body is used, shorten the O-rings by twisting.
4. Follow the previously described precision bracket alignment method, align the radio starting with the site and later fine tune using the scope for increased accuracy.

V3000 tilt bracket assembly

1. Fix the mounting plate of the tilt bracket to the back of the radio using four of the short bolts, ensuring that the arrow in the plate points towards the top of the radio. Tighten the four bolts to a torque setting of 5.0 Nm (3.7 lb ft) using a 13 mm spanner or socket.



2. Fit the two long bolts through the bracket body so that the bolt heads engage in the slots as shown. Fit two of the short bolts into the side of the bracket body but do not tighten.

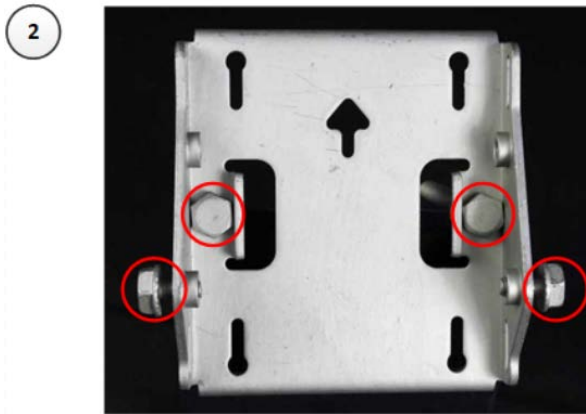

3. Thread two of the nuts to the long bolts and tighten against the bracket body using a 13 mm spanner. Fit the bracket strap and thread the remaining nuts onto the long bolts.

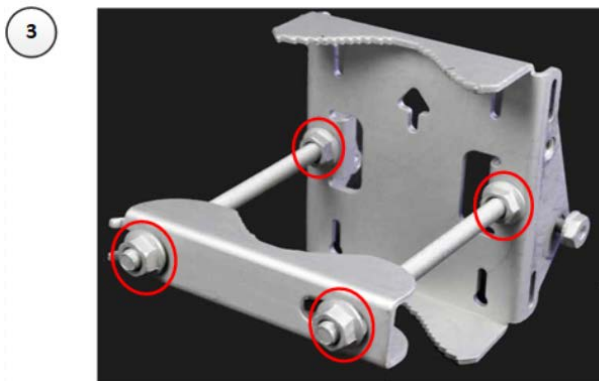

4. Fix the assembled bracket body to the pole, adjust the azimuth angle, and tighten the nuts to a torque setting of 10.0 Nm (7.4 lb ft) using a 13 mm spanner, ensuring that the arrow in the body is pointing upwards.

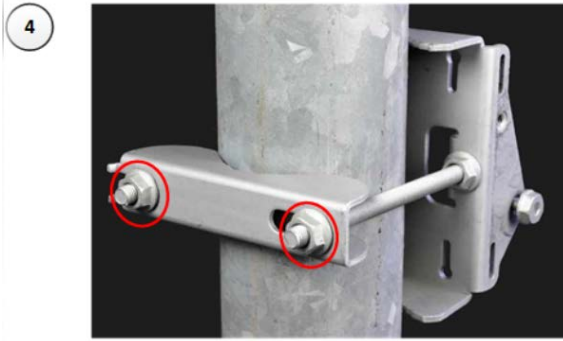

5. Fit the mounting plate to the bracket body by positioning the open- ended slots over the short bolts. Insert the remaining short bolts through the longer curved slots into the threaded holes in the bracket body. Adjust the elevation angle and tighten the bolts to a torque setting of 5.0 Nm (3.7 lb ft) using a 13 mm spanner or socket.

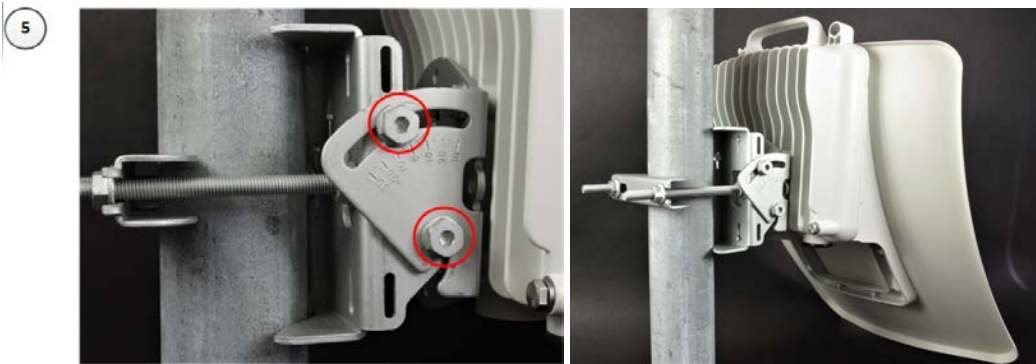

V3000 tilt bracket assembly with band clamps

Follow the below instructions to assemble the tilt bracket with band clamps:

1. Follow step 1 of the [V3000 tilt bracket assembly](#) procedure.
2. Feed the band clamps through the slots in the bracket body. Secure the bracket body to the pole using band clamps (not supplied by Cambium), ensuring that the arrow in the body is pointing upwards. Adjust the azimuth angle, and tighten the band clamps to a torque setting of 6.0 Nm (4.5 lb ft).
3. Fix the mounting plate to the bracket body with four of the short bolts, using a 13 mm spanner or

socket. Adjust the elevation angle, and tighten the bolts to a torque setting of 5.0 Nm (3.7 lb ft).

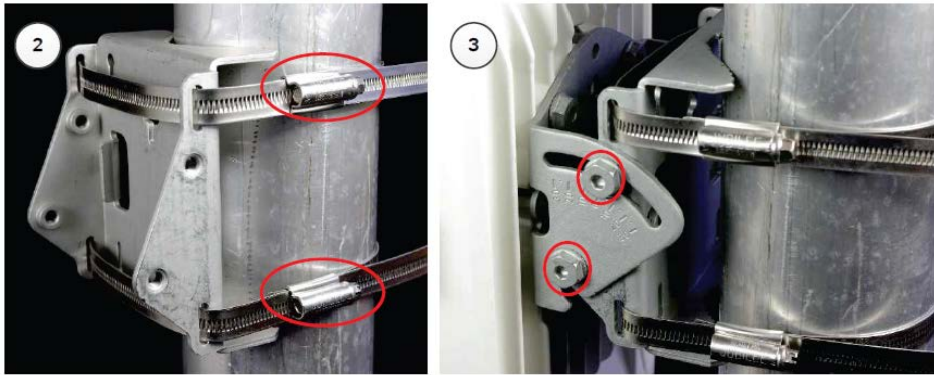

V5000 pole mount bracket

1. Pass the long screws through the bracket body. The screws locate in the recess in the bracket.
2. Fit two flanged nuts to the long screws on the back of the bracket. Tighten using a 13 mm spanner.
3. Fix the bracket to the back of the radio using the four short M6 bolts, ensuring that the arrow in the plate points towards the top of the radio. Tighten the four bolts to a torque setting of 5.0 Nm (3.7 lb ft) using a 13 mm spanner or socket.
4. Attach the pole-mount bracket to the pole using the clamp and the remaining flanged nuts. Adjust azimuth and tighten the nuts to 10 Nm (7.4 lbft) using a 13 mm spanner.

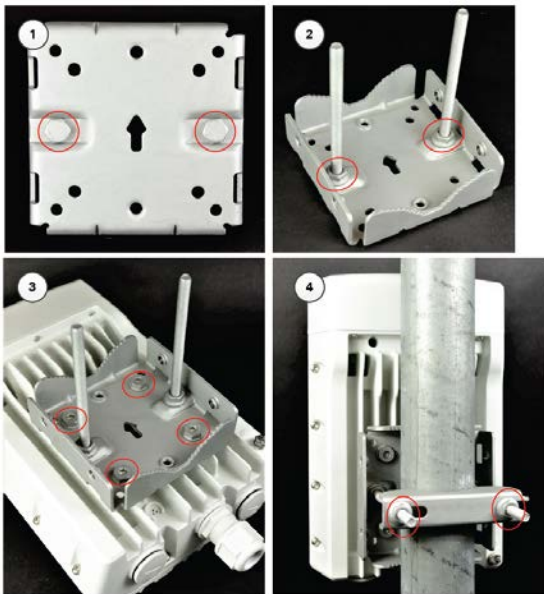

V5000 alignment

The V5000 distribution node has two sectors, situated side by side, each covering 140 degree range in azimuth, giving a combined coverage of 280 degrees. In elevation, the antenna can beam steer in a +/- 20 degree range. The boundary between where Sector 1 ends and Sector 2 begins is the centreline/boresight from the unit.

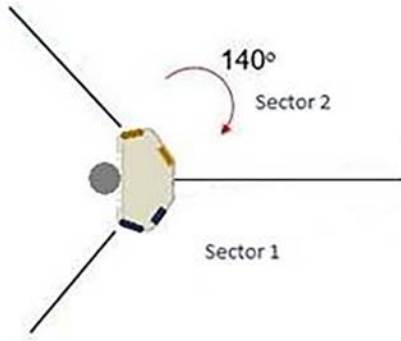

Figure 7: V5000 alignment - Top view

V5000 wall mount bracket

1. Install the mounting plate of the wall mount bracket securely on a vertical wall, using suitable fixing hardware.



Note

Fixing hardware is not supplied with the wall mount bracket.

2. Fix the bracket body to the back of the radio using the four short M6 bolts, ensure that the arrow in the plate points towards the top of the radio. Tighten the four bolts to a torque setting of 5.0 Nm (3.7 lb ft) using a 13 mm spanner or socket.
3. Insert the four short M8 bolts into the sides of the bracket body.
4. Fit the bracket body to the mounting plate by positioning the short bolts into the open-ended slots. Tighten the bolts to a torque setting of 5.0 Nm (3.7 lb ft) using a 13 mm spanner or socket.

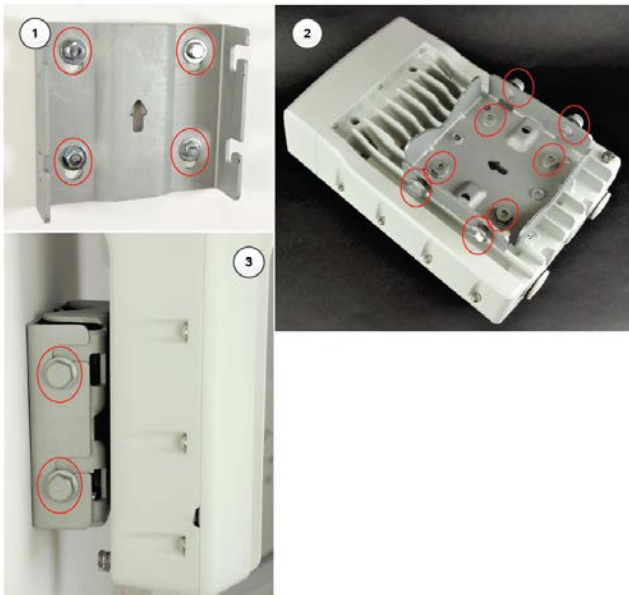

Connect to the PSU port of the radio

Using power over Ethernet (PoE)

1. Disassemble the gland and thread each part onto the cable (the rubber bung is split). Assemble the spring clip and the rubber bung.



2. Fit the parts into the body and lightly screw on the gland nut (do not tighten it).



3. Connect the RJ45 plug into the main PSU port of the ODU.



4. Rotate the gland clock wise to tightly fit the gland on the PSU port.



Warning

Ensure that the cable clamp is not attached/ tightened at this stage, this may cause damage to the RJ45 or PCB.



5. Tighten the gland (cap or nut), this must be done last. Otherwise it may damage the RJ45 or PCB.

Disconnecting drop cable from the radio

1. Loosen and remove cable clamp by rotating anti-clockwise from the PSU port.



Warning

Loosen the cable clamp completely and then unscrew the gland. Not releasing the cable may cause damage to the RJ45 socket and/or PCB.

2. Remove the gland.

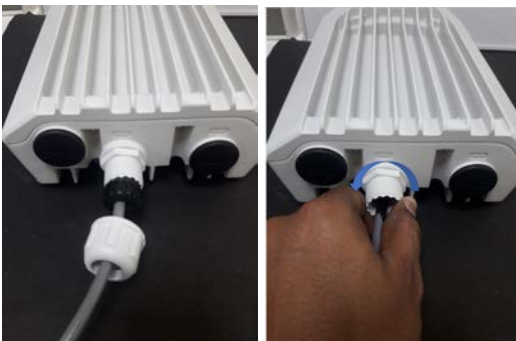

3. Press tab on RJ45 plug to remove the cable from PSU port.
4. Remove the latch of the RJ45 plug to remove the cable from PSU port.



Using AC/DC PSU

Cable joiner

Cable joiner is used to connect the wires. Insert the wires into the cable joiner by loosening the screws on the joiner.



Mini adapter connections

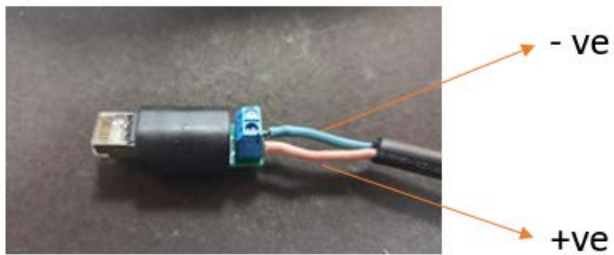

Fitting the long cable gland



Connecting mini adapter to ODU

1. Plug and connect input side of the AC/DC PSU to AC power line and tighten the gland. Tighten the cable clamp cap.



2. Connect output side of DC PSU to ODU through cable joiner and DC mini adapter.



Install the PSU

Install one of the following types of PSU:

- [Installing the 60W DC power injector](#)
- [Installing the AC/DC PSU](#)
- [Installing the V1000 power injector](#)



Warning

Always use an appropriately rated and approved AC supply cord-set in accordance with the regulations of the country of use.



Attention

As the 60W DC power injector and V1000 power injector are not water proof, locate it away from sources of moisture, either in the equipment building or in a ventilated moisture-proof enclosure. Do not locate the PSU in a position where it may exceed its temperature rating.



Attention

Do not plug any device other than a 60 GHz cnWave™ ODU into the ODU port of the PSU. Other devices may be damaged due to the non-standard techniques employed to inject DC power into the Ethernet connection between the PSU and the ODU.

Do not plug any device other than a Cambium 60 GHz cnWave™ PSU into the PSU port of the ODU. Plugging any other device into the PSU port of the ODU may damage the ODU and device.

Installing the 60W DC power injector

1. Connect the input side of DC power injector to AC power line.

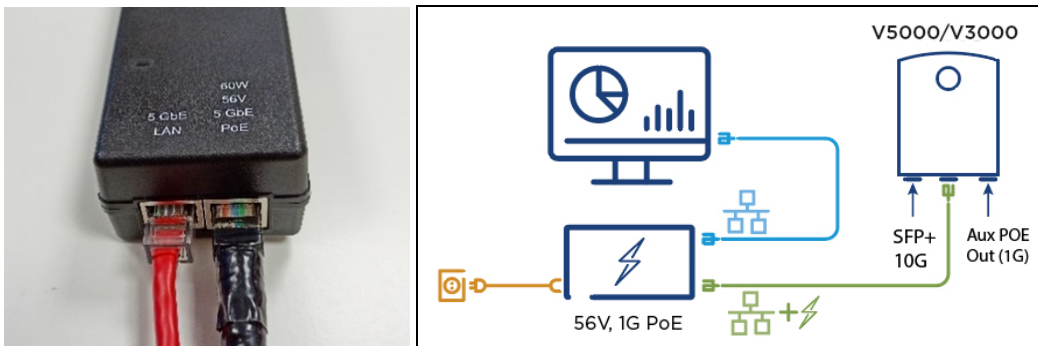

Figure 8: 60W DC power injector

2. Connect 5 Gbe LAN port of the power injector to network equipment.
3. Connect 60 W 56V 5 GbE PoE port of the power injector to ODU drop cable.



Installing the AC/DC PSU

1. Connect input side of the AC/DC PSU to AC power line.
2. Connect output side of DC PSU to ODU through cable joiner and DC mini adapter. Refer [Cable joiner](#) section for connecting, installing cable joiner and mini adapter.



Figure 9: AC/DC PSU (N000000L179B)



Figure 10: Cable joiner



Figure 11: DC to RJ45 plug, Mini adaptor

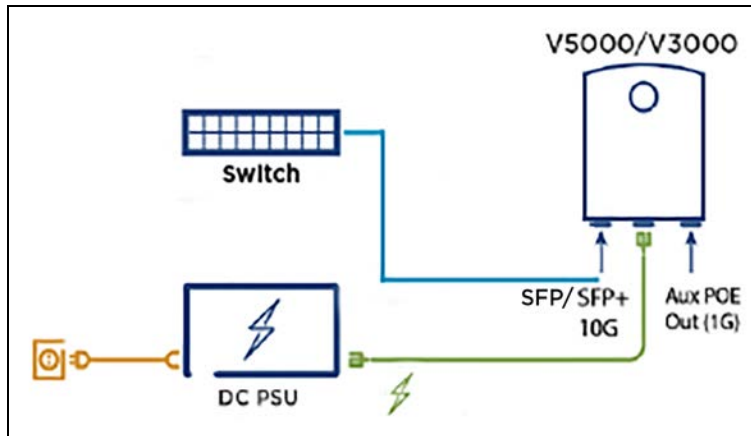

Figure 12: AC/DC powering diagram



Figure 13: AC/DC PSU

For detailed assembly of cable joiner and mini adapter to ODU PSU port, refer [Cable joiner](#) section.



Note

Both short and long glands can be used to connect to outdoor PSU.

Installing the V1000 power injector

1. Connect the 56V Gigabit Data + power port to ODU and Gigabit data port to the network equipment.



Figure 14: V1000 power injector

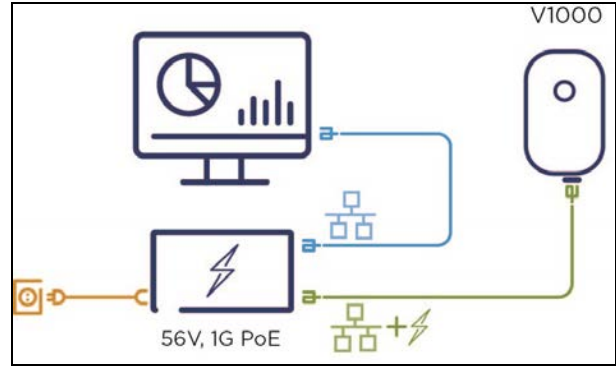

Figure 15: V1000 powering diagram



Connecting to the SFP+ optical module or SFP+ to copper module to ODU

When ODU is powered through AC/DC PSU, an optical or copper Cat6A Ethernet interface can be connected to the SFP port of the ODU for data interface.

Adapt the installation procedures in this section as appropriate for SFP interfaces, noting the following differences from a PSU interface.

Fitting the long cable gland

Optical SFP interface: Disassemble the long cable gland and thread its components over the LC connector at the ODU end as shown below.

Copper CAT6A SFP interface: Disassemble the cable gland and thread its components over the RJ45 connector at the ODU end.

1. Disassemble the long cable gland used for optical SFP interface.



Disassemble the long cable gland used for copper SFP interface.



2. Thread each part onto the cable (the rubber bung is split).



3. Fit the parts into the body and lightly screw on the gland nut (do not tighten it).

Optical



Copper



Inserting the SFP module

To insert the SFP module into the ODU, follow the below steps:

1. Remove the blanking plug from the SFP port of the ODU.



Optical SFP+ module



Copper SFP module



2. Insert the SFP module into the SFP receptacle with the label on bottom.

Optical



Copper



3. Push the module home until it clicks into place.

Optical



Copper



4. Rotate the latch to the locked position.

Optical



Copper



Connecting the cable



Attention

The Fiber optic cable assembly is very delicate. To avoid damage, handle it with extreme care. Ensure that the fiber optic cable does not twist during assembly, especially when fitting and tightening the weatherproofing gland. Do not insert the power over Ethernet drop cable from the PSU into the copper SFP module, as this will damage the module.

1. Remove the LC connector dust caps from the ODU end (optical cable only).

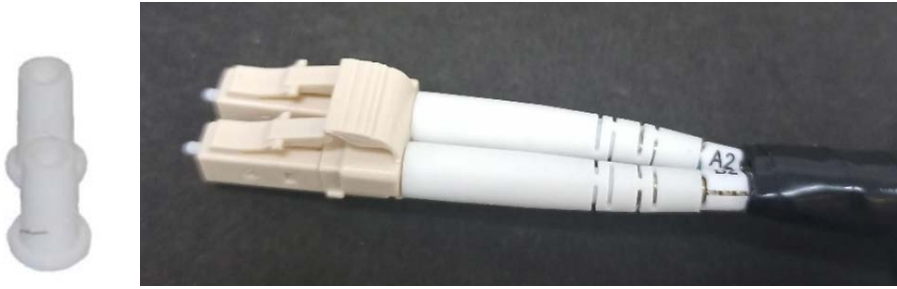

2. Plug the connector into the SFP module, ensuring that it snaps home.

Optical



Copper



Fitting the gland

1. Fit the gland body to the SFP port and tighten it to a torque of 5.5 Nm (4.3 lb ft).



2. Fit the gland nut and tighten until the rubber seal closes on the cable. Do not over-tighten the gland nut, as there is a risk of damage to its internal components.



3. Fit the gland nut to the rubber seal on the gland body and tighten it to a torque of 5.5 Nm (4.3 lb ft).



Removing the cable and SFP module

Do not attempt to remove the module without disconnecting the cable, otherwise the locking mechanism in the ODU will be damaged.

1. Remove the cable connector by pressing its release tab before pulling it out.

Optical



Copper



2. Pull the bale clasp (latch) to the unlocked position. Extract the module by using a screwdriver.

Optical



Copper



Chapter 6: Configuring 60 GHz cnWave™

Nodes deployment

The configuration of cnWave nodes is handled automatically by the E2E service. However, the first PoP node must be configured manually since connectivity to the E2E controller has not yet been established. After establishing communication with the E2E controller, the nodes report a hash of their local configuration file and the controller automatically pushes configuration changes to the nodes upon seeing any mismatches. Centralized configuration management architecture implemented in which the E2E controller, serves as the single point of truth for configurations in the network.

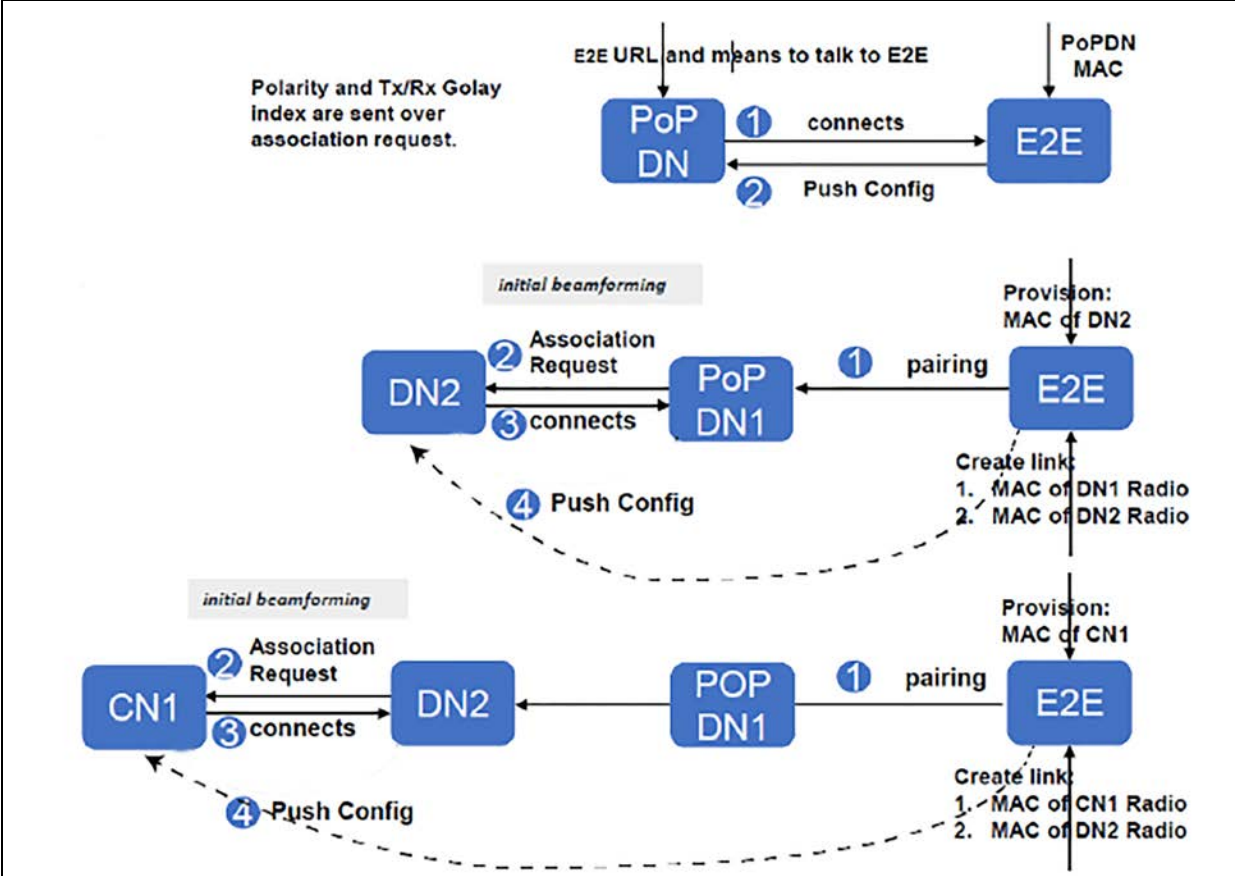

Figure 1: Nodes deployment

Connecting to the unit

This section describes how to connect the unit to a management PC and power it up.

Configuring the management PC

Use this procedure to configure the local management PC to communicate with the 60 GHz cnWave™ devices.

Procedure:

1. Select **Properties** for the Ethernet port. In Windows 7 this is found in **Control Panel > Network and Internet > Network Connections > Local Area Connection**.
2. Select **Internet Protocol Version 4 (TCP/IPv4)**.

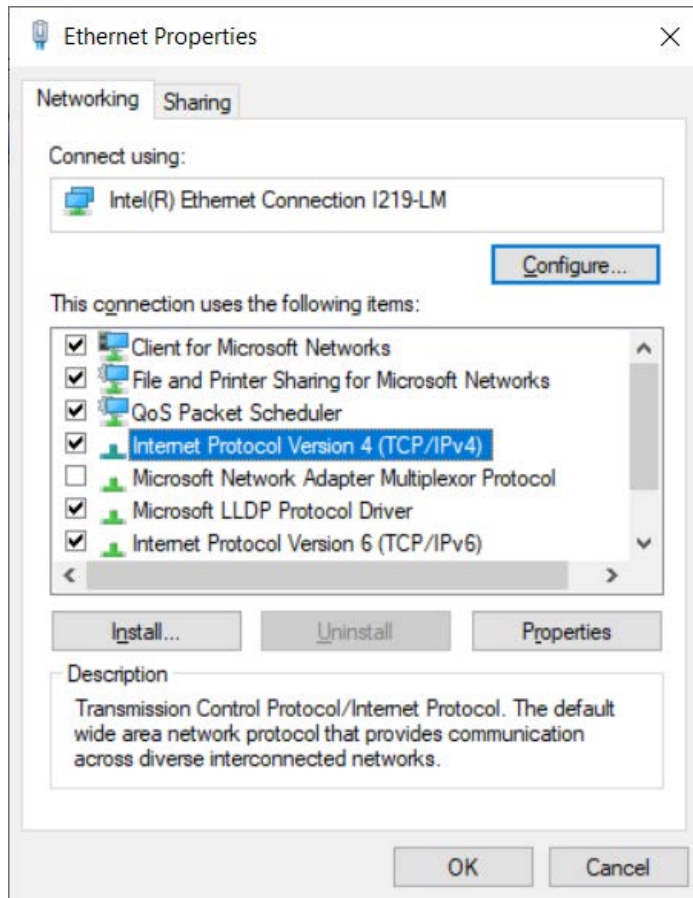

3. Click **Properties**.
4. Enter an IP address that is valid for the 169.254.X.X/16 network, avoiding 169.254.1.1 (eg: 169.254.1.3).

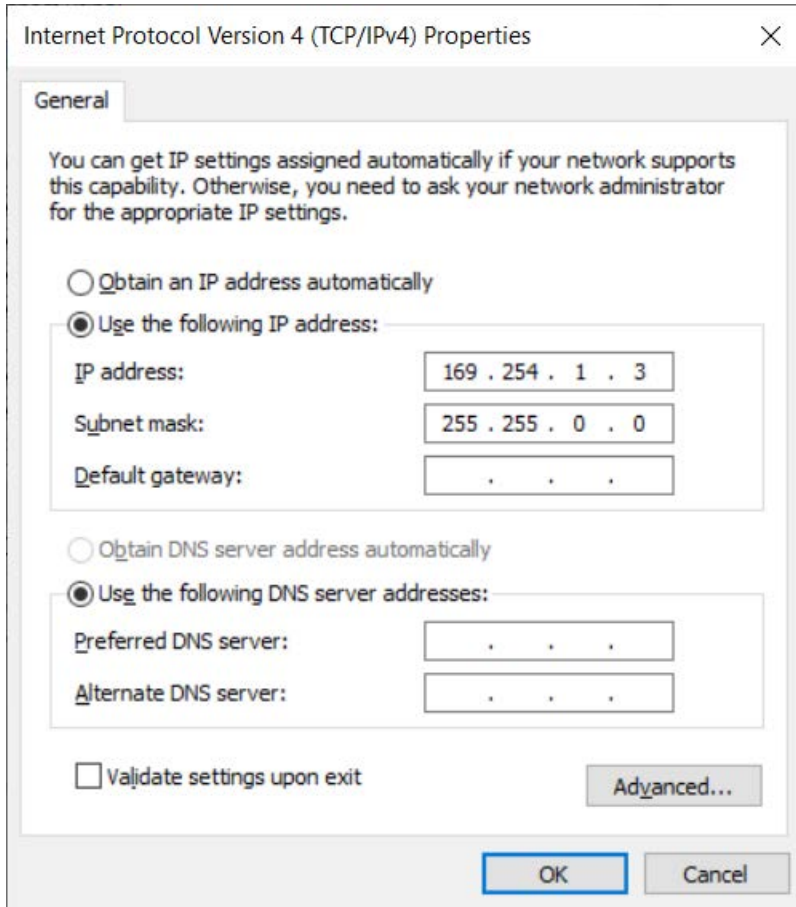

5. Enter a subnet mask of 255.255.0.0. Leave the default gateway blank.

Connecting to the PC and powering up

Use this procedure to connect a management PC and power up the 60 GHz cnWave™ devices.

Procedure:

1. Check that the ODU is connected to the power supply (AC/DC according to the configuration).
2. Connect the PC Ethernet port to the LAN port of the PSU or AUX port (according to device configuration).
3. Open a web browser and type: **169.254.1.1**.
4. When prompted, enter **admin/admin** to login to the GUI and complete the configuration.

Using the web interface

This section describes how to log into the 60 GHz cnWave™ web interface and use its menus.

Logging into the web interface

Use this procedure to log into the web interface as a system administrator.

Procedure:

1. Start the web browser from the management PC.
2. Type the IP address of the unit into the address bar. The factory default IP address is **169.254.1.1** and press **Enter**.

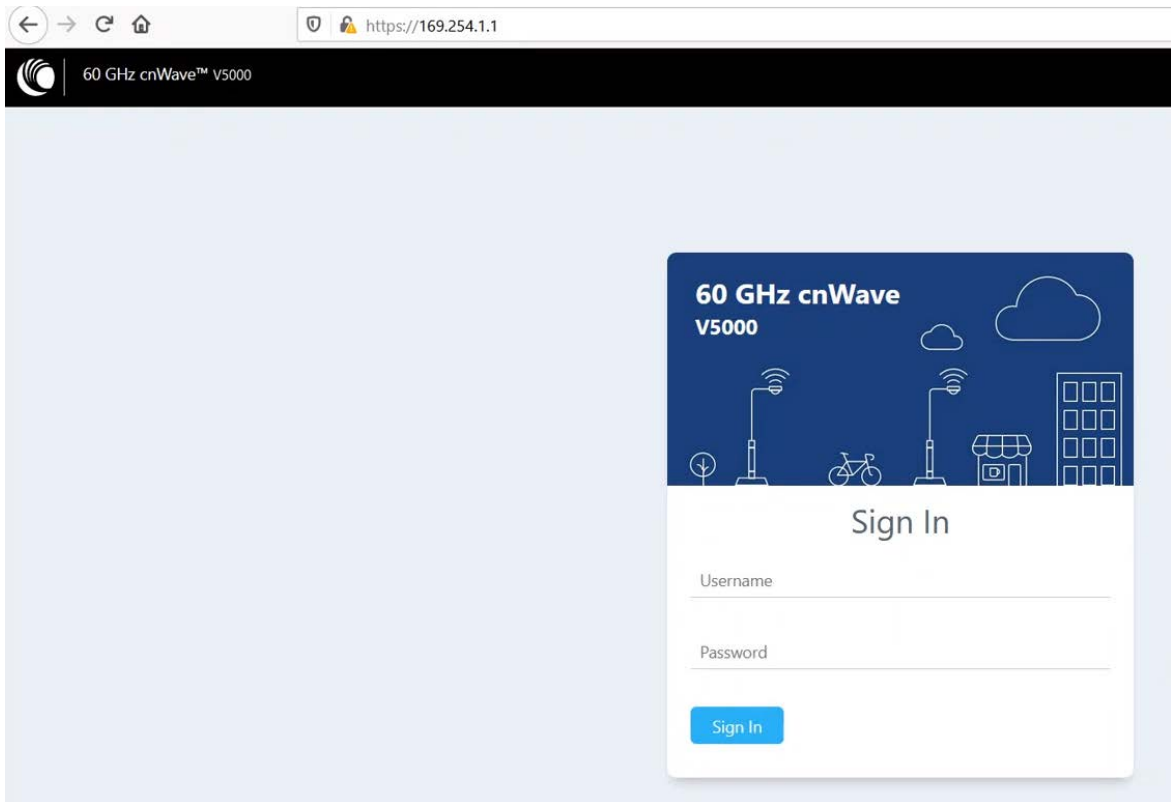

3. Type the username and password as **admin** and **admin**. Click **Sign In**.

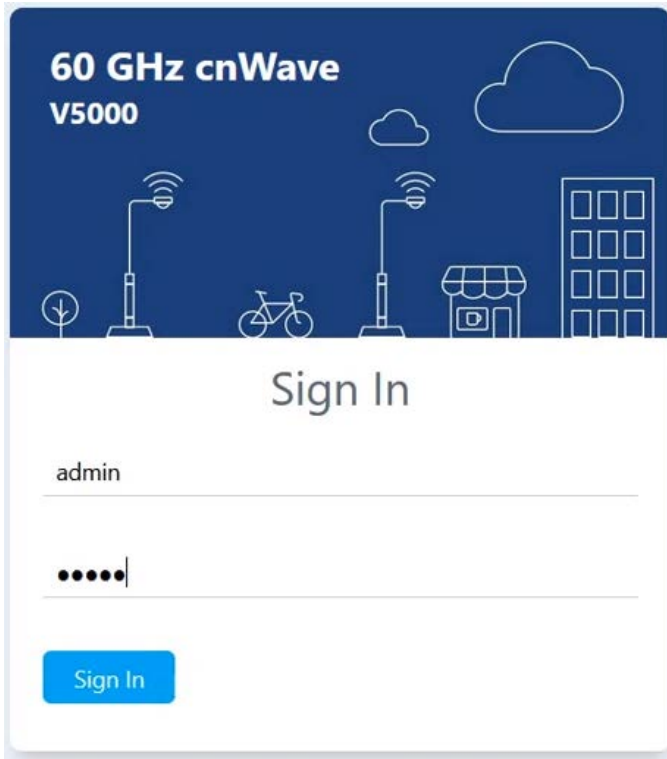

The **Dashboard** page appears.

The image shows the dashboard page for the 60 GHz cnWave V5000 device. The page is titled "Dashboard" and displays various system metrics and configuration details. The top navigation bar includes a "Reboot" button and the user name "admin".

Dashboard Summary:

- Uptime: 0d 4h 16m
- Links: 2 (Total Links)
- Channels: 3 (Sector 1), 1 (Sector 2)
- Wireless Throughput: 3.86 Gbps (RX), 267.70 Mbps (TX)

Device Information:

Type	POP
Name	pop
E2E Connection Status	Onboarded
MAC Address	00:04:56:88:30:0c
Serial Number	X100008300C
Model	V5000
Software Version	1.0-sf6
Firmware Version	10.11.0.79
Wireless Security	PSK
Layer 2 Bridge	Disabled
System Time	Dec 17, 2020, 1:33:04 PM

GPS:

Fix Type	3D
Satellites tracked	15
Latitude	12° 56' 2.176" N
Longitude	77° 41' 39.940" E
Height	930 m

Sectors:

	Sector 1	Sector 2
Channel	3	1
Sync Mode	GPS	GPS
MAC Address	12:04:56:88:30:0c	22:04:56:88:30:0c
Active Links	1	1
RX Throughput	1.90 Gbps	1.95 Gbps
TX Throughput	17.83 Mbps	249.87 Mbps

Ethernet:

	Aux	Main	SFP
Status	1000 Mbps	10000 Mbps	10000 Mbps
RX Packets	629262	436688100	1238548778
TX Packets	786281	3923553278	108974047
RX Throughput	3.65 kbps	265.81 Mbps	974.86 Mbps
TX Throughput	37.85 kbps	4.84 Gbps	3.66 Mbps

Copyright © 2020 Cambium Networks, Ltd. All rights reserved. | [Contact Us](#) | [Support](#) | [License](#)

User can select the refresh time interval. Click **admin** at the top-right and select the **Refresh Interval** from the drop-down.

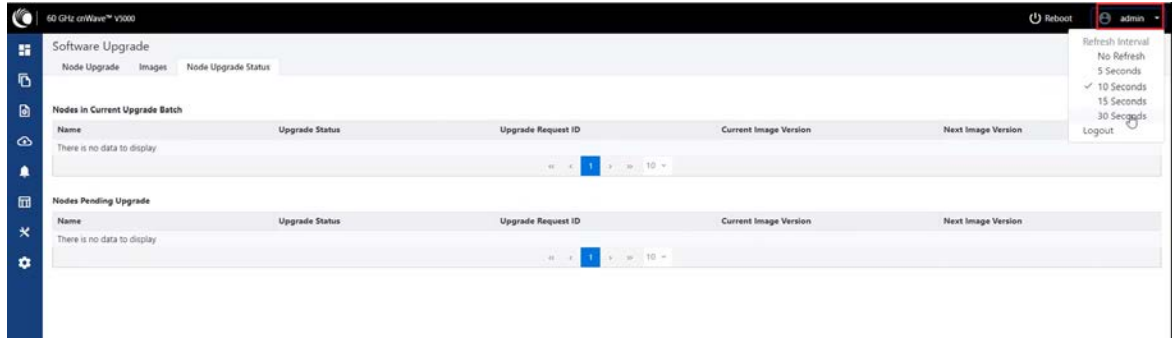

The Dashboard contains the following options at the top:

- Uptime
- Links
- Channels
- Wireless Throughput

Uptime

Displays the total running time of the device.

Links

Displays the total number of active links which are connected to the 60 GHz cnWave™ device.

Channels

Displays the total number of channels (Sector 1, Sector 2 etc.,) which are connected to the 60 GHz cnWave™ device.

Wireless Throughput

Displays the transmitting and receiving throughput values.

Dashboard elements

Dashboard home page consist of the below elements:

- Device Information
- GPS
- Sectors
- Ethernet

Device Information

Device Information	
Type	DN
Name	-
E2E Connection Status	Not Onboarded
MAC Address	00:04:56:88:31:21
Serial Number	V5WH004ZNX7V
Model	V5000
Software Version	1.0-dev12
Firmware Version	10.11.0.70
Wireless Security	None
Layer 2 Bridge	Disabled
System Time	Nov 5, 2020, 12:12:57 PM

Figure 2: Dashboard - Device Information

Element	Description
Type	Displays type of the device. The device types are: <ul style="list-style-type: none"> • DN • PoP DN • CN
Name	Displays name of the device
E2E Connection Status	Displays the connection status of the E2E controller
MAC address	Displays the MAC address of the 60 GHz cnWave™ device
Serial Number	Displays the serial number of the 60 GHz cnWave™ device
Model	Displays the model of the 60 GHz cnWave™ device. The models are: <ul style="list-style-type: none"> • V1000 • V3000 • V5000
Software version	Displays the software version used in 60 GHz cnWave™ device
Firmware version	Displays the Firmware version used in 60 GHz cnWave™ device
Wireless security	Displays the security type. The types are: <ul style="list-style-type: none"> • Disabled

Element	Description
	<ul style="list-style-type: none"> • PSK • 802.1X
Layer 2 Bridge	Displays bridge status
System Time	Displays current time

GPS

GPS table displays the positioning information of the site.

GPS	
Fix Type	3D
Satellites tracked	15
Latitude	12° 56' 2.163" N 
Longitude	77° 41' 39.912" E 
Height	927 m

Figure 3: Dashboard - GPS

Element	Description
Fix Type	Fix Type
Satellites tracked	Number of registered satellites
Latitude	Displays latitude of the site
Longitude	Displays longitude of the site
Height	Displays height of the device

Sectors

Sectors table displays the number of nodes added to the device and its information.

Sectors		
	Sector 1	Sector 2
Channel	3	4
Sync Mode	RF	RF
MAC Address	12:04:56:88:31:21	22:04:56:88:31:21
Active Links	0	0
RX Throughput	0 kbps	0 kbps
TX Throughput	0 kbps	0 kbps

Figure 4: Dashboard - Sectors

Element	Description
Channel	Displays the channel information used by the sector
Sync mode	Displays the sync mode of the sectors
MAC address	Displays the MAC address of the sectors
Active links	Displays the number of active links in connected sectors
RX Throughput	Displays RX Throughput of the individual sectors
TX Throughput	Displays TX Throughput of the individual sectors

Ethernet

Ethernet table displays the information about Aux, Main and SFP ports.

Ethernet			
	Aux	Main	SFP
Status	1000 Mbps	10000 Mbps	10000 Mbps
RX Packets	637166	445648283	1250718835
TX Packets	777923	3983518625	109768893
RX Throughput	14.46 kbps	348.40 Mbps	974.40 Mbps
TX Throughput	28.78 kbps	4.84 Gbps	3.65 Mbps

Figure 5: Dashboard - Ethernet

Element	Description
Status	Displays the speed of Ethernet ports
RX Packets	Number of packets received
TX Packets	Number of packets transmitted
RX Throughput	Displays the RX Throughput of the Ethernet
TX Throughput	Displays the TX Throughput of the Ethernet

Enabling internal E2E Controller

E2E Controller handles important management functions such as link bring-up, software upgrades and configuration management, etc. Enable E2E Controller to configure and establish the connection. To enable E2E Controller, perform the following steps:



Note

The internal E2E controller is not required if you intend to tune the E2E controller On-Premise (refer *E2E User Guide*).

The internal E2E controller is restricted to 21 node.

1. Click **E2E Controller** option on left pane of the Dashboard.

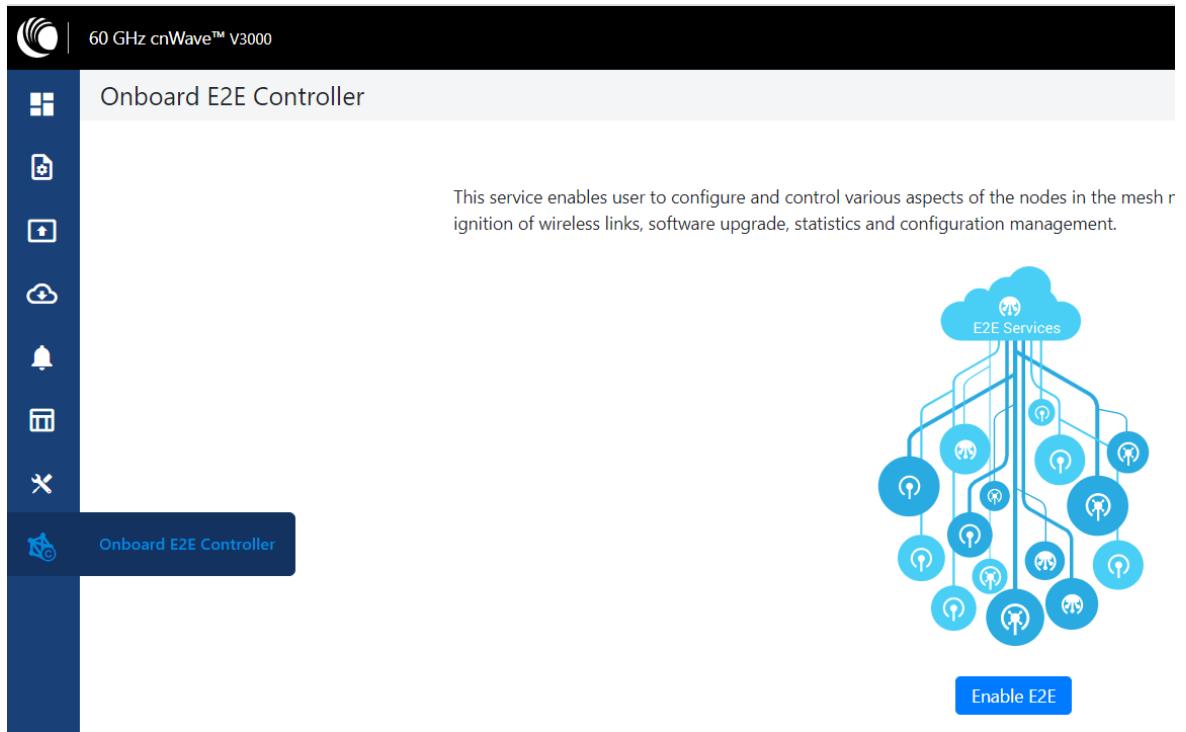

2. Click **Enable E2E**.

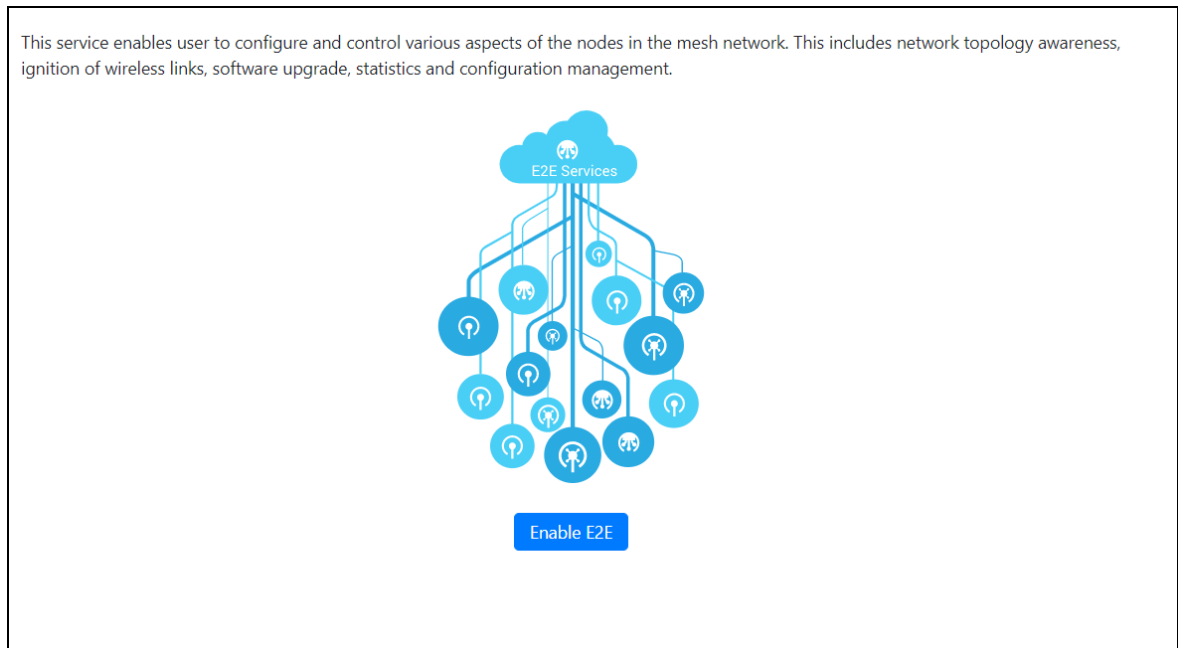

The **Enable Onboard E2E** dialog box appears.

Enable Onboard E2E ✕

Site Name

Default site name

Latitude

Longitude

Device Name

Default device name

Network Settings

IPv4 Address

Subnet Mask

Gateway IP Address

Controller Settings

Enable Layer 2 bridge

3. Enter the required details and click **Enable**.
4. After enabling E2E Controller, dashboard displays the links which are connected to the device.

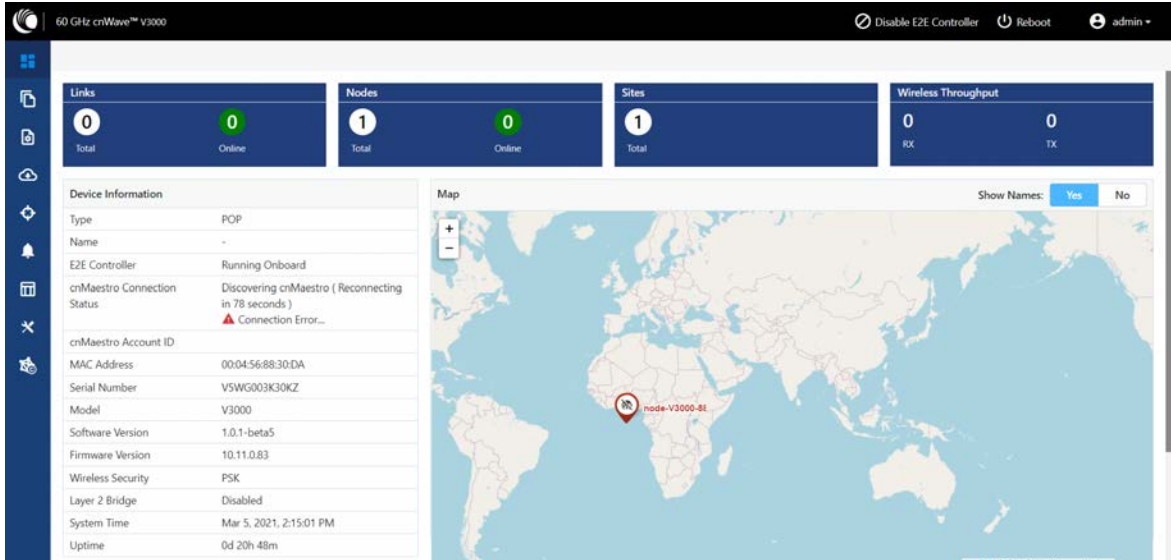
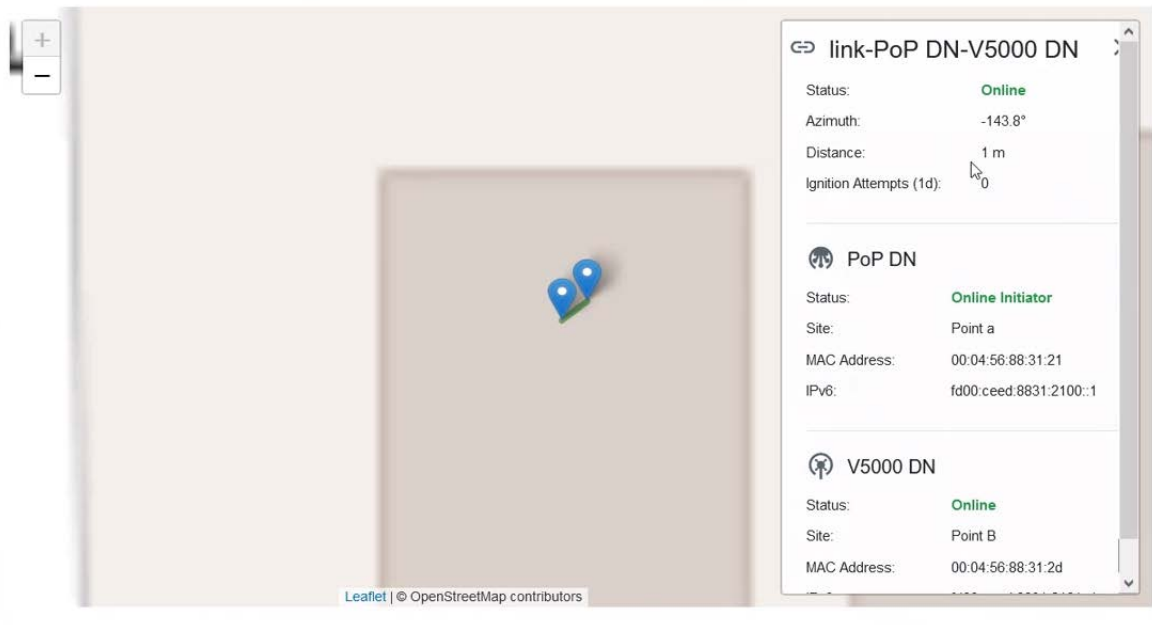

Figure 6: Dashboard

Right-click on the site pin to see more information about the site.



Topology

After enabling E2E Controller, add Sites, Nodes and Links to establish the connection. Click **Topology** at the left-pane.

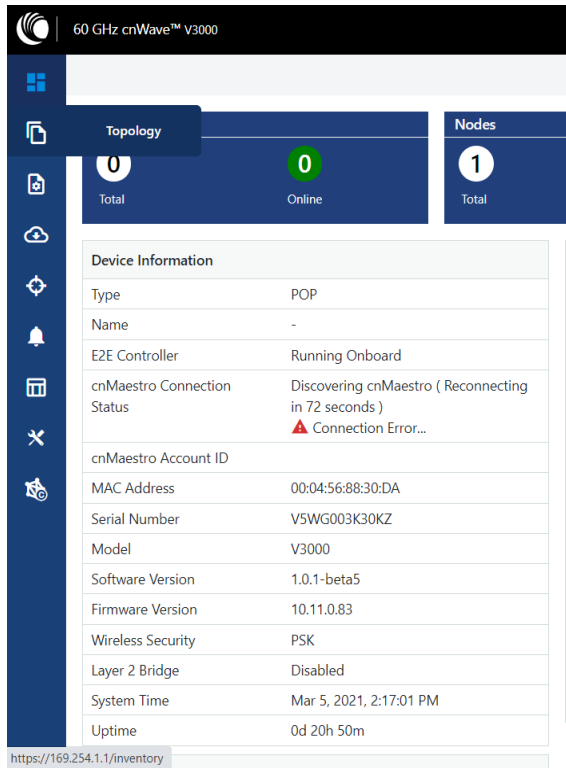
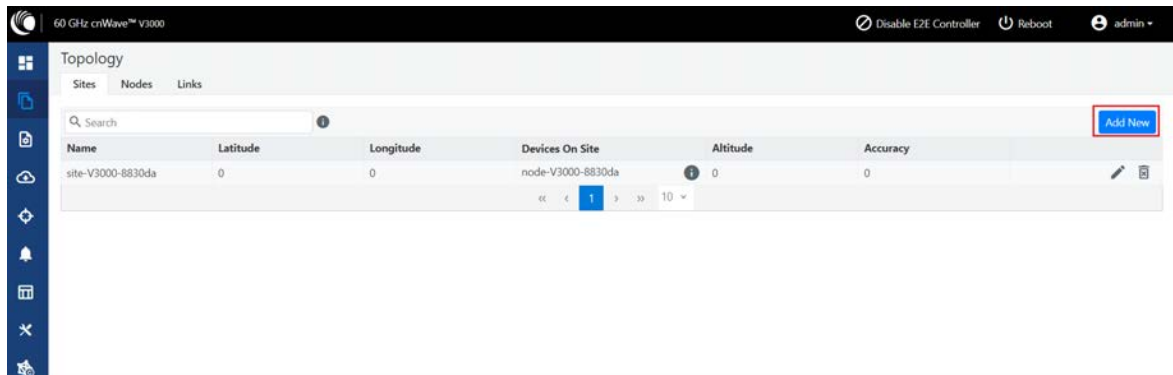

Figure 7: Topology menu

To add Sites, Nodes and Links perform the below steps:

1. Click **Sites** on the top and click **Add New** to add new site.



2. Enter the Name, Latitude, Longitude, Altitude, Accuracy information and click **Save**.

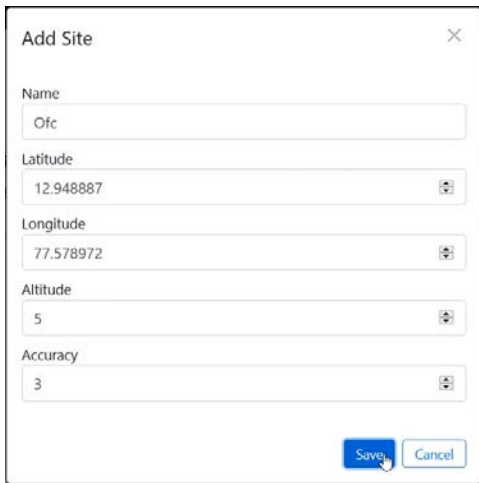

The 'Add Site' dialog box contains the following fields and values:

- Name: Ofc
- Latitude: 12.948887
- Longitude: 77.578972
- Altitude: 5
- Accuracy: 3

Buttons: Save, Cancel

A new site is added to the topology.

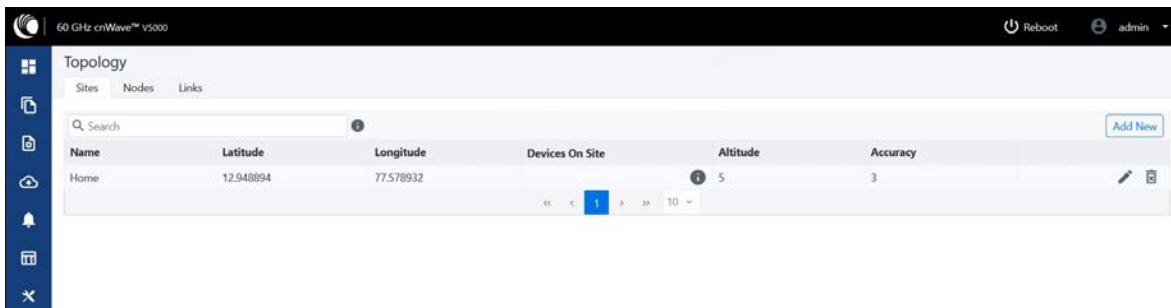

The 'Topology' page shows the 'Sites' tab with the following table:

Name	Latitude	Longitude	Devices On Site	Altitude	Accuracy
Home	12.948894	77.578932		5	3

3. Click **Nodes** at the top and click **Add new**.

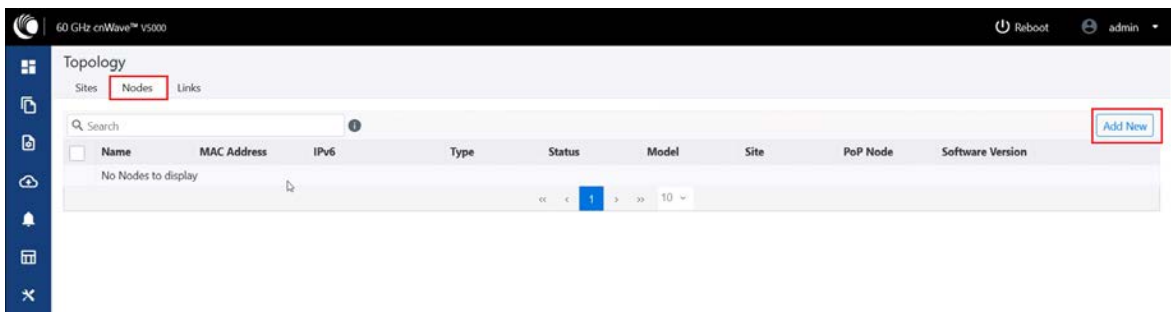

The 'Topology' page shows the 'Nodes' tab with the following table:

Name	MAC Address	IPv6	Type	Status	Model	Site	PoP Node	Software Version
No Nodes to display								

4. Enter the required information and click **Save**.

Add Node ✕

The local node is not yet added. Select this checkbox to pre-fill data for the local node.

Name

Site

PoP Node?
 Yes No

Node Type
 CN DN

Hardware
 Primary Secondary

MAC Address (ESN)

Platform

Azimuth

Elevation

POP Routing
 Static Routing Border Gateway Protocol (BGP) Routing

POP Interface
 Aux Main SFP Disabled

The interface that the PoP node uses to communicate with the upstream router

POP Interface IP Address

[Generate](#)
IPv6 address on the interface that the PoP node uses to communicate with the upstream router



Note
For the first node, select **Yes** under **PoP Node** and select **Primary** under **Hardware** for primary node that is added after PoP node.

5. Click **Link** on the top and click **Add New**.

Name	A-Node	A-Node Sector	Z-Node	Z-Node Sector	Active	Uptime	Type	Ignition Attempts (1d)	Distance (m)	Ignition Status
link-Point B-V1000	Point B	-	V1000	-	Yes	0d 0h 12m	Wired	0		Enabled

6. Select nodes of the links, which forms the sectors and click **Save**.

The 'Add Link' dialog box contains the following fields and options:

- Name:** A text input field containing the value 'link'.
- A-Node:** A dropdown menu.
- Node-1 Wireless MAC:** A dropdown menu.
- Z-Node:** A dropdown menu.
- Node-2 Wireless MAC:** A dropdown menu.
- Link Type:** Radio buttons for 'Wireless' (selected) and 'Wired'.
- Buttons:** 'Save' and 'Cancel' buttons at the bottom right.

Node rename support

Node can be renamed in the topology. To rename the node, perform the following steps:

1. Navigate to **Topology > Nodes**.
2. Select the required node, click **⋮**, and select **Edit Node**.
3. Rename the node and click **Save**.

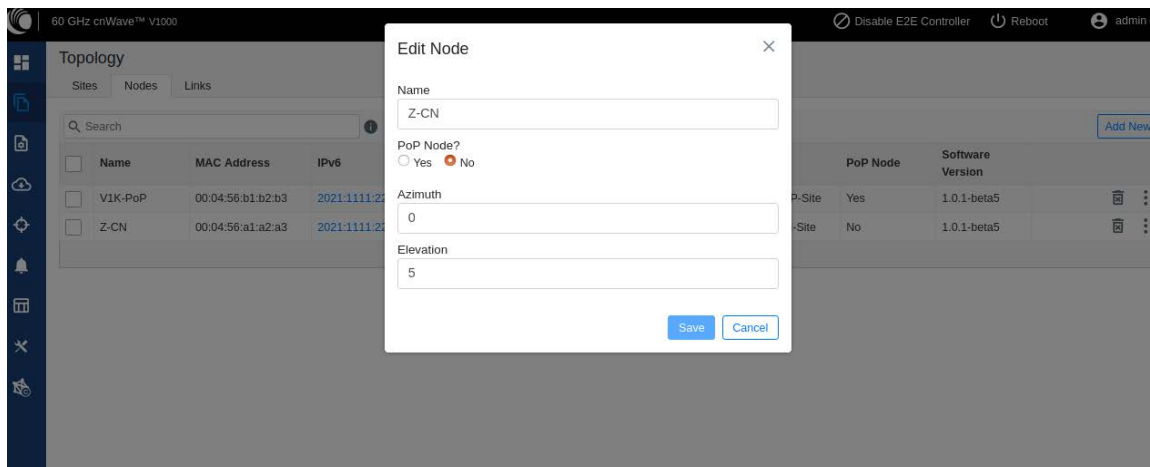

Configuration

Configuration page contains two configuration options:

- [Network configuration](#)
- [Node configuration](#)

Network configuration

Network configuration is used to configure the network. User can modify the network settings. It has **Basic**, **Management**, **Security** and **Advanced** options for the configuration. Settings under **Network** applies to all the nodes in the network. Some apply to the **E2E Controller**. Enter the required information and click **Submit** to configure the network. Network configuration contains the following tabs:

- [Basic tab](#)
- [Management tab](#)
- [Security tab](#)
- [Advanced tab](#)

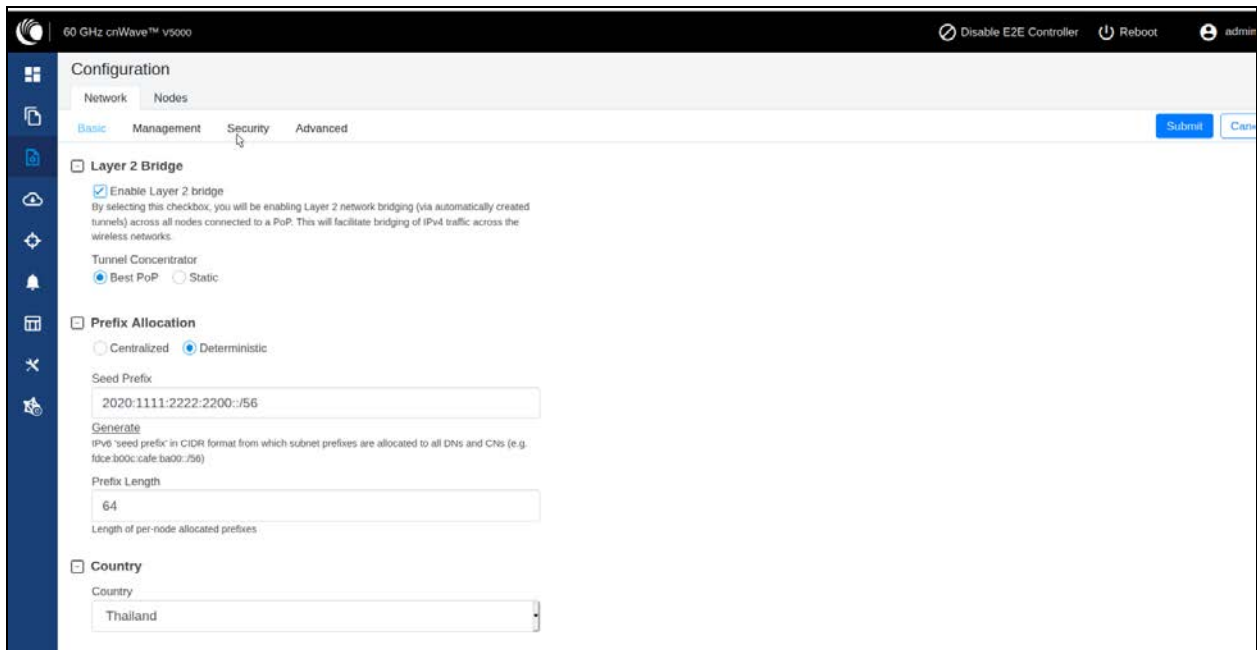
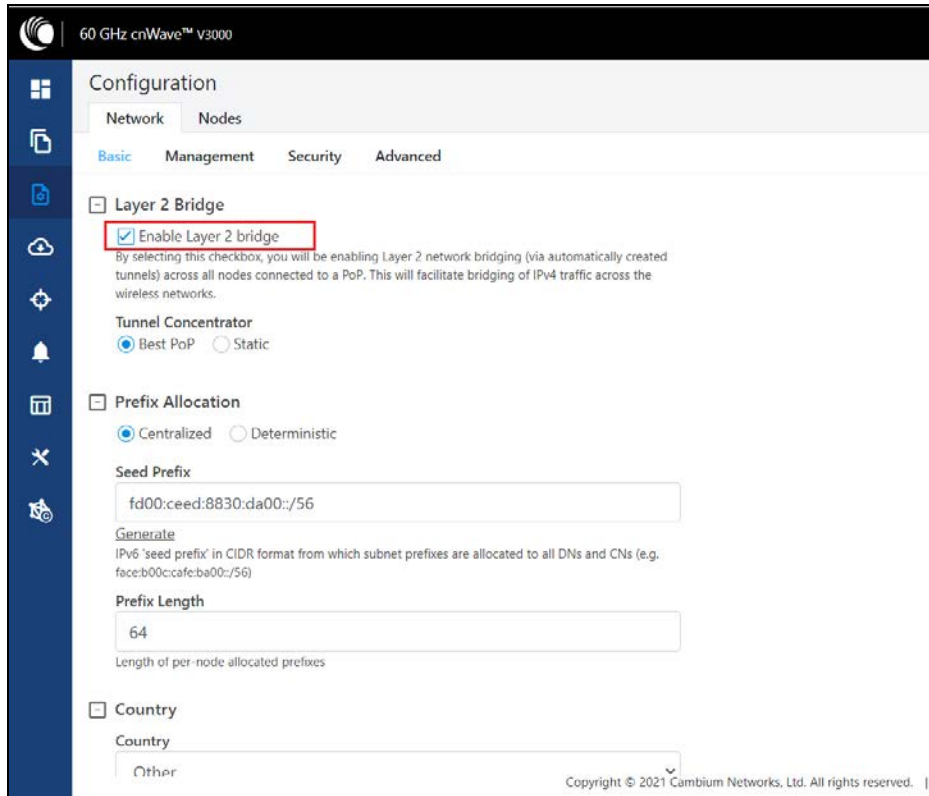

Figure 8: Configuration menu

Basic tab

1. By default, cnWave is a IPv6 only network. By selecting this checkbox, Layer 2 network bridging is enabled (via automatically created tunnels) across all nodes connected to a PoP. This facilitates bridging of IPv4 traffic across the wireless networks.



The **Tunnel Concentrator** does encapsulation and de-encapsulation of GRE packets. If **Best PoP** is selected, then the node selects best PoP as a Concentrator. If **Static** is selected, then the user can configure the external Concentrator that can be Linux machine / router / PoP.

2. Click **Generate** under **Prefix Allocation** to generate unique local seed prefix automatically.

cnWave networks are given an IPv6 **seed prefix** (e.g. face:b00c:cafe:ba00::/56) from which subnet prefixes are allocated to all DNS and CNs. There are two methods for allocating node prefixes with Open/R.



Note

PoP interface IPv6 address and seed prefix should not be in the same /64 prefix range to avoid the address conflict.

- **Centralized (default)** - Centralized prefix allocation is handled by the E2E controller. The controller performs all prefix allocations, which prevents collisions and enables more sophisticated allocation algorithms. This is recommended for single PoP networks
- **Deterministic** - Deterministic prefix allocation is also handled by the E2E controller. The controller assigns prefixes to nodes based on the network topology to allow PoP nodes to take advantage of route summarization and help load balance ingress traffic. This is recommended for multi-PoP networks.

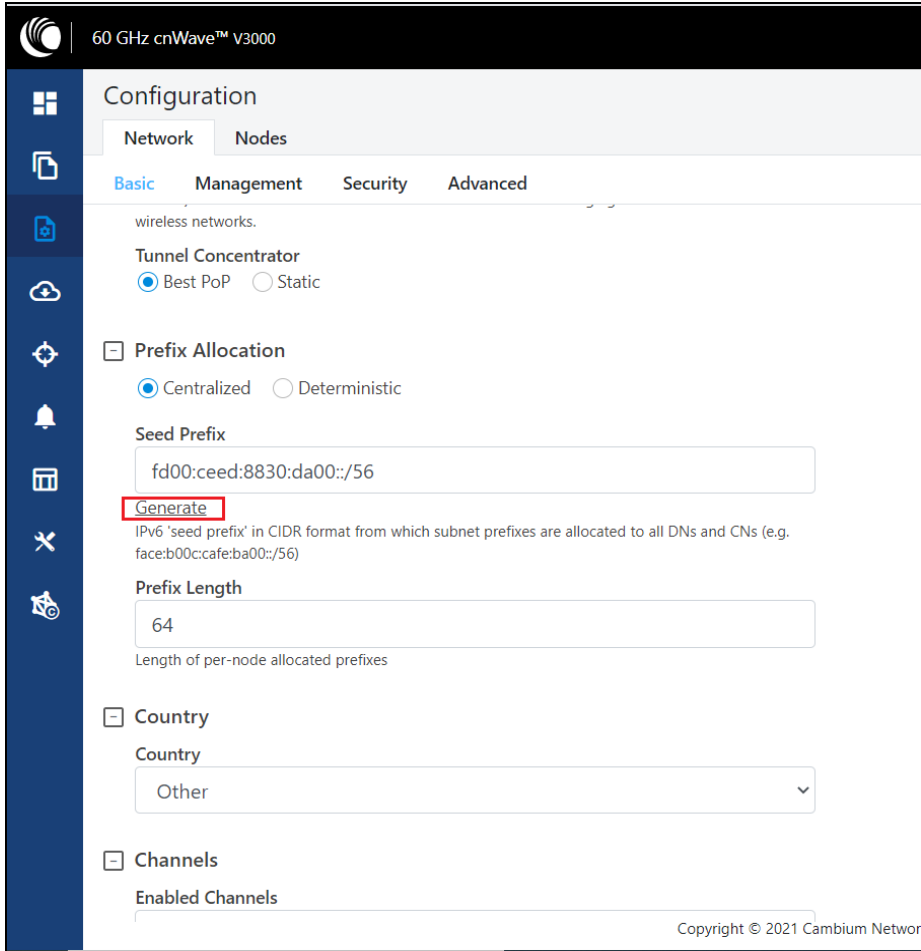

Seed Prefix

The prefix of the seed of the entire cnWave network, is given in CIDR notation.

3. Select **Prefix Length**, **Country**, **Channels**, **DNS Servers**, and **Time zone** from the drop-down.

Prefix Length

Specifies the bit-length of prefixes allocated to each node.

Country

Country for regulatory settings like EIRP limit, allowed channels.

Channels

The comma separate list of channels given to the controller for auto configuration. Manual settings in **Node > Radio** page do not depend on this setting. This setting is useful especially for PTP and small meshes that use single channel for the entire network. In such cases, set the required channel here and do not override in the **node > Radio** page. Changing this setting alone does the channel change, .

DNS Servers

DNS server list used for :

- Resolution of NTP Sever host name (can be IPv4 when Layer 2 bridge is enabled)
- Given to IPv6 CPE as part of router advertisement

Time Zone

Time zone for all the nodes. System time in the dashboard, time field in the Events section, Log files use this timezone.

NTP Servers

This is NTP Sever FQDN or IP Address. All nodes use this NTP Sever to set the time. Node time is important when 802.1X radius authentication is used as it requires certificate validation. The time is reflected in the dashboard, time field in the Events section, and Log files .

4. Enable **E2E Manged Config**.

E2E Managed Config determines whether the controller manages the node's configuration. It is highly recommended to keep it **enabled**.

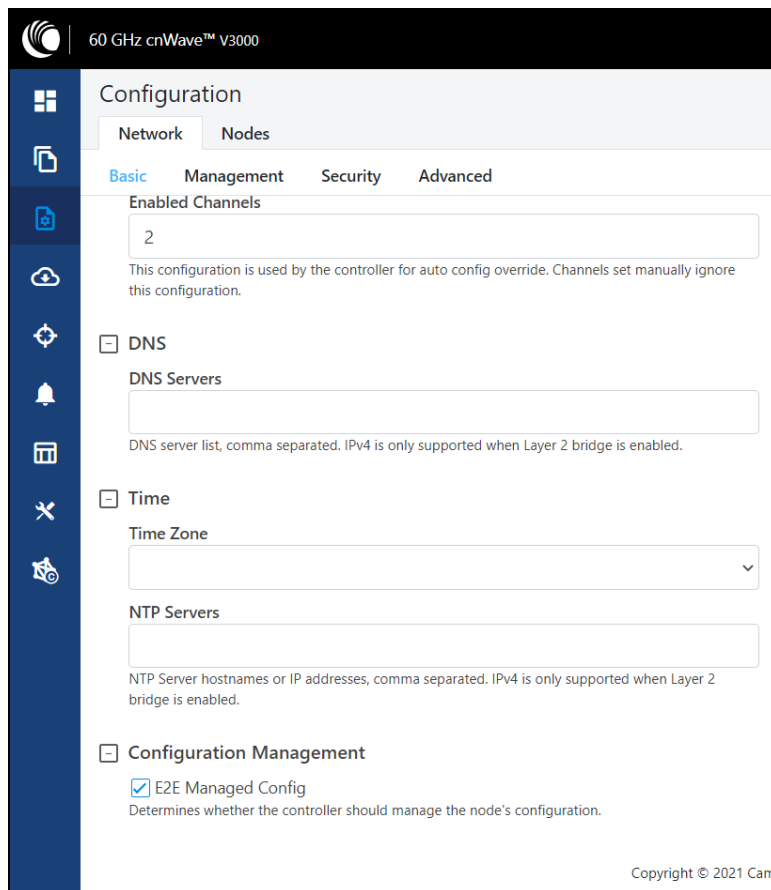

5. **Wireless Scans (Scheduled Beam Adjustment)** - This feature runs a PBF scan at every defined Scan Interval. Navigate to **Configuration > Network > Basic > Wireless Scans** to run a PBF scan. The 60 GHz cnWave™ products can align the wireless link within an azimuth / elevation range by selecting from a number of fixed beams.

Wireless Scans

Scheduled Beam Adjustment

Enabled Disabled

Scan Interval

86400

Interval between wireless scans in seconds

A normal scan without Scheduled Beam Adjustment does the following operations:

- Beam selection occurs only on wireless link acquisition.
- Disassociating and re-associating the link or otherwise causing the link to drop and re-acquire is needed to perform a new beam selection.
- Any degradation in the wireless conditions does not trigger a new beam selection unless the link drops and reacquires.

The advantages of the Scheduled Beam Adjustment scan are:

- If the link is to acquire during heavy rain, then the optimal beam at that time may be suboptimal when the weather changes.
- If snow accumulation is present on the unit during acquisition, the optimally selected beam may be different when the snow has melted.
- Network wide ignition in a dense deployment can cause interference when multiple nodes are acquiring. This interference can cause sub-optimal beam selection.
- Any physical change to alignment that is not severe enough to cause a link drop and subsequent beam scan can be corrected for.

The cost of Scheduled Beam Adjustment are:

- This feature causes a network wide outage of approximately **two minutes**. For this reason, unless there is a specific issue being addressed, it is recommended to either disable this feature or configure an interval of ≥ 24 hours.
- Simple deployments (especially PTP links) without significant external factors such as snow may not benefit from regular beam adjustment.

Management tab

Click **Management** and select SNMP, SNMPv2 Settings, SNMPv3 Settings, GUI User name and password.

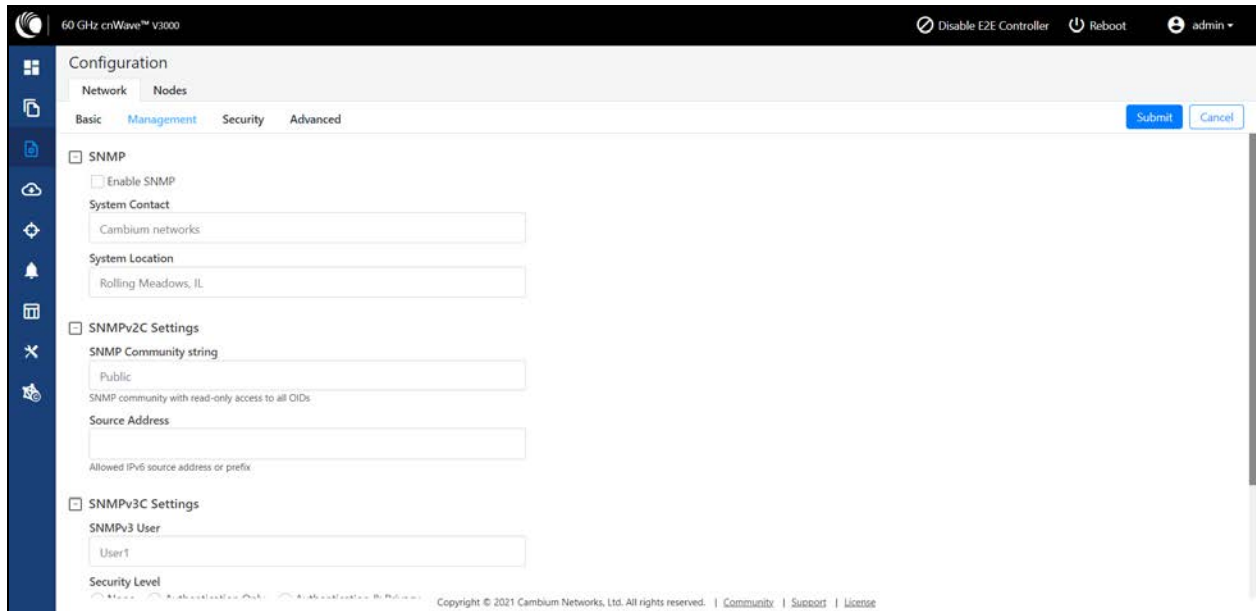

Figure 9: Management tab

- **Enable SNMP** - Statistics can be read from the nodes using SNMP. This setting enables SNMP.
- **System Contact** - Sets the contact name as the System.sysContact.0 MIB-II variable.
- **System Location** - Sets the location name as the System.sysLocation.0 MIB-II variable.
- **SNMP Community string** - Read only SNMP community string
- **Source address** - When specified, SNMP queries are allowed from the hosts belonging to this IPv6 prefix.
- **User Passwords** - Password for the GUI users can be configured here. Monitor is a read only user.

Security tab

Security tab contains **Disabled**, **PSK**, and **RADIUS Server** options for Wireless Security. Select the required option.

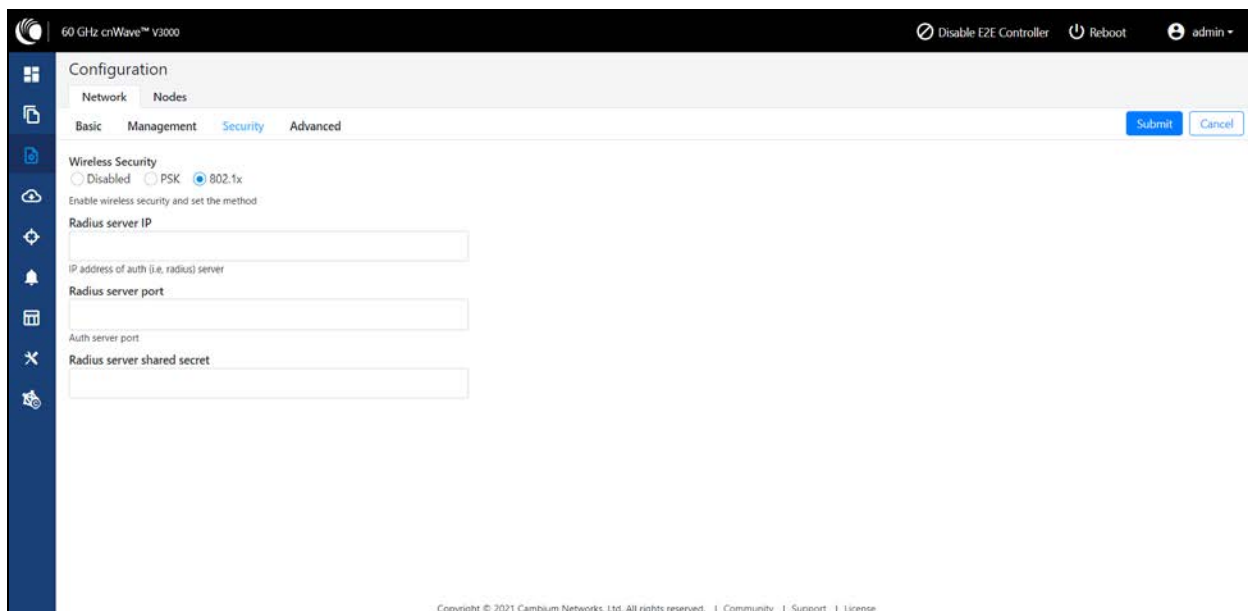

Figure 10: Security tab

Wireless Security

- **Disabled** - there is no wireless security.
- **PSK** - WPA2 pre-shared key can be configurable. A default key is used if this configuration is not present. AES-128 encryption is used for data encryption.
- **802.1X** - Nodes are authenticated using radius server and uses EAP-TLS. Encryption is based on the negotiated scheme in EAP TLS.

RADIUS Server IP - IPv6 address of radius authentication server.

RADIUS Server port - Radius authentication server port.

RADIUS server shared secret - Shared secret of radius server.

Advanced tab

These settings are for the advanced users only. Displays the merged configuration off all layers for a particular node.



Caution

The users are not recommended to do these settings.

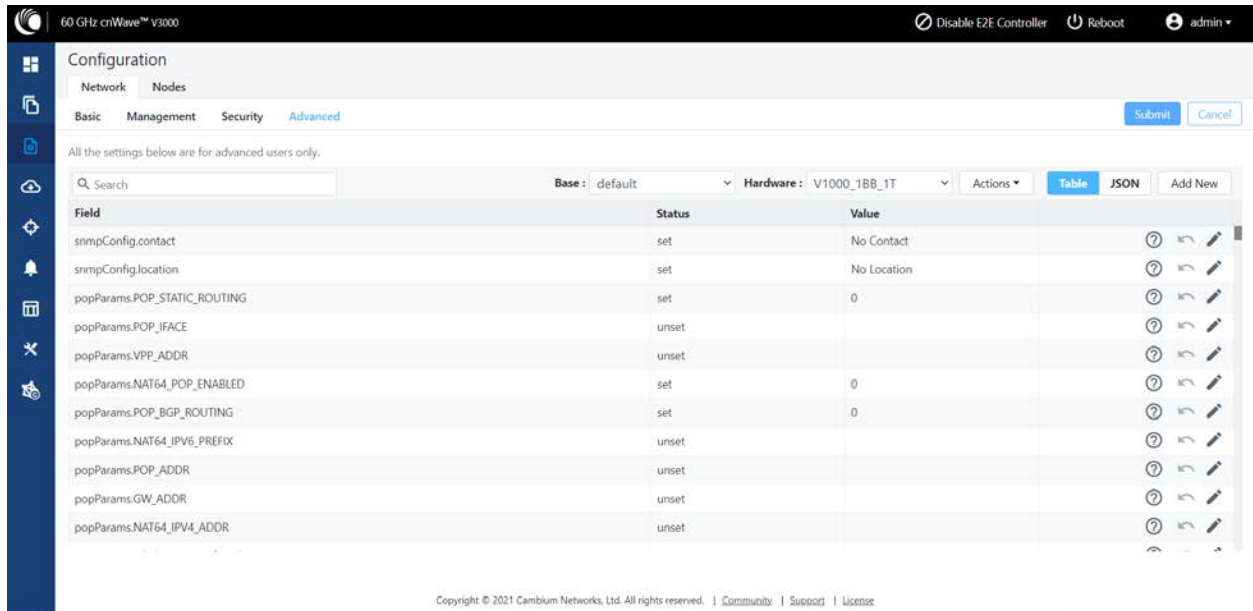

Figure 11: Advanced tab

Node configuration

Node configuration is used to configure the nodes via E2E Controller. E2E Controller can modify the node settings. Select the node(Radio) on left pane to modify the settings. Node configuration contains the following tabs:

- [Radio tab](#)
- [Networking tab](#)
- [VLAN tab](#)
- [Security tab](#)
- [Advanced tab](#)

Radio tab

These settings apply to individual nodes selected in the left side panel. Select the required options for Transmit Power, Adaptive Modulation, Sector 1, Sector 2 from the drop-down. Enable **Force GPS Disable** to establish the link between indoor nodes.

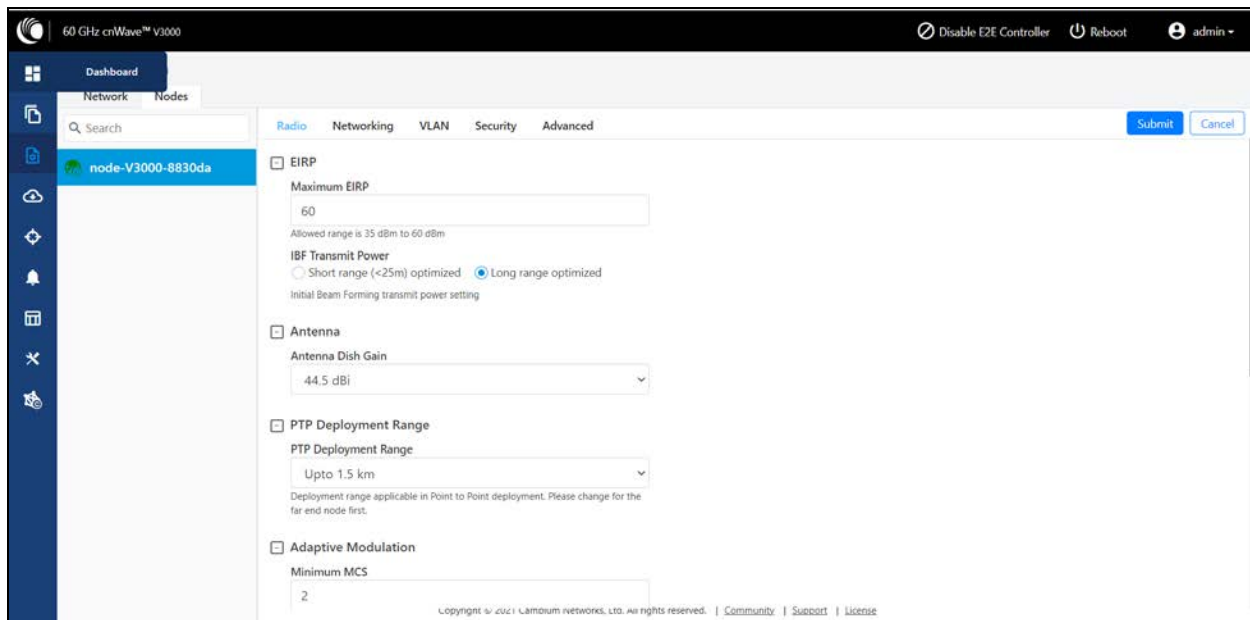



Figure 12: Radio tab

Radio tab contains the following elements:

Elements	Description
Transmit Power	<p>Transmit power of the radio</p> <ul style="list-style-type: none"> • Maximum EIRP - The maximum EIRP transmitted by the radio. Range differs based on the platform and country selected (in Network page). • IBF Transmit power - Transmit power using during initial beam forming. When all the links are in short range, high transmit power can cause interference. Selecting short range optimized will prevent this. Post beam forming, automatic power control will make sure the radio transmits at optimal power.
Adaptive Modulation	Select minimum and maximum coding scheme ranging from 2 to 12.
Sector 1	<ul style="list-style-type: none"> • Select the frequency channel and polarity. • Channel and Polarity - When link is created in topology, controller automatically sets the sector's channel and polarity. To manually override, click check box and select the channel in the node config. Note that changing channel/polarity breaks the link. Its important to change for leaf nodes first and then higher up on DNs.
Sector 1 Link (s) Golay	Golay codes help in avoiding inter sector interference. In rare scenarios, individual links might requires separate Golay codes. Most scenarios, all the link belonging to a sector are configured same Golay code. Controller automatically sets the Golay code. To manually override, select the check box and set the Golay from the drop down. Override All button helps in setting the same Golay code for all the links.

Elements	Description
	 <div style="background-color: #e1f5fe; padding: 5px;"> <p>Note</p> <p>Golay codes and frequency on the both ends of the link should match.</p> </div>
Sector 2	Select the frequency channel and polarity.
Sector 2 Link (s) Golay	Golay code.
GPS	If enabled then, the radio uses internal sync rather than the GPS sync. In some scenarios like lab setups, it may be necessary to disable GPS.



Caution

60 GHz cnWave™ V1000 and V3000 devices has only **Sector 1**.

V3000 Small dish support

The software allows selection of smaller 40.5 dBi antenna dish. To select V3000 small dish, navigate to **Configuration > Nodes > Radio > Antenna**.

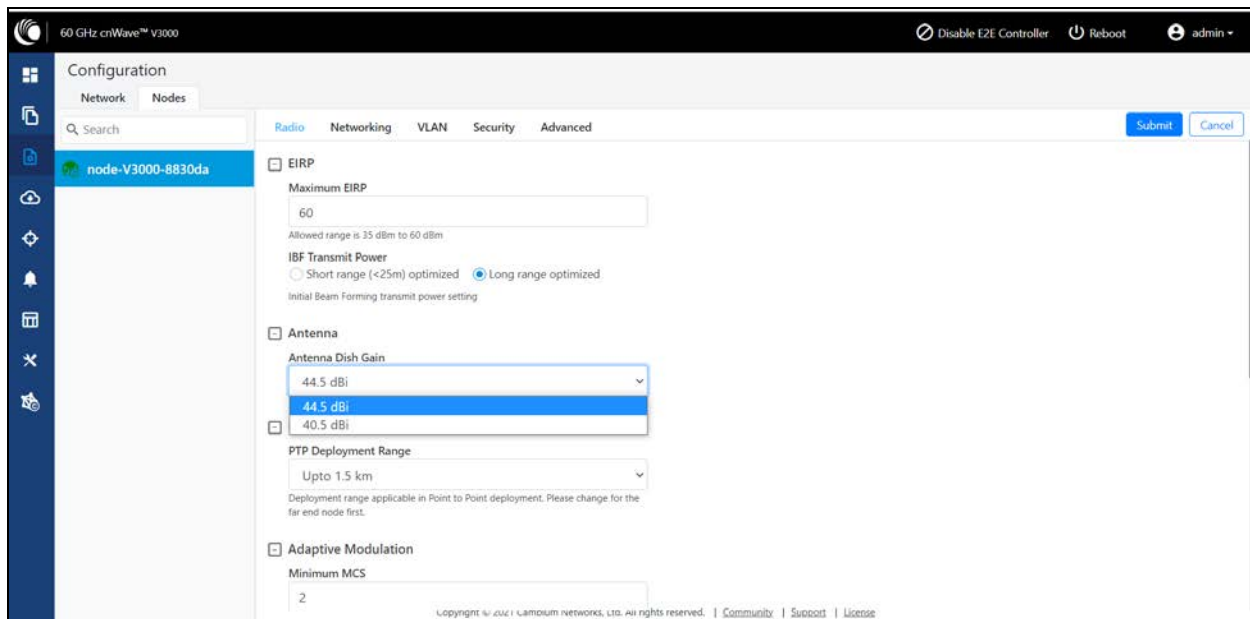

Caution

Small dish is supported only for 60 GHz cnWave™ V3000.

Networking tab

In **Networking** tab, perform the following step:

1. Enter the local IPv4 address.

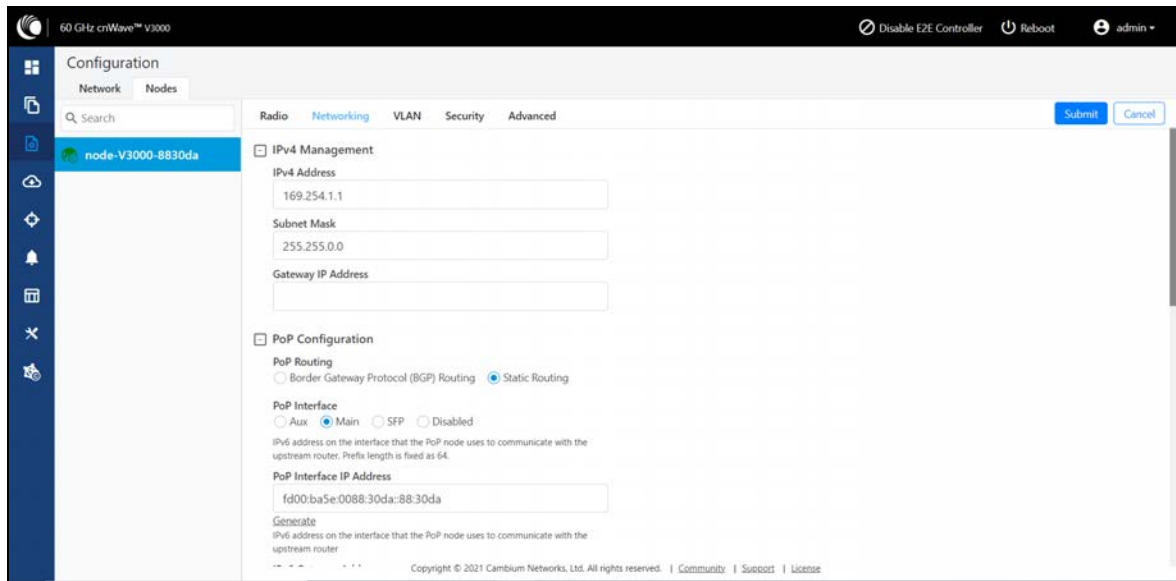

Elements	Description
IPv4 Address	Static IPv4 address of the individual node. Node's GUI /CLI can be opened using this IP address when directly connected over Ethernet. For Over the air access, L2 Bridge should be enabled. Its predominantly used on PoP nodes with onboard controller.
Subnet Mask	Subnet mask for the IPv4 address.
Gateway IP Address	IPv4 Gateway address.

2. Under **PoP Configuration**, select the options for **PoP Routing**, **PoP Interface** and click **Generate** to generate **PoP Interface IP Address**.

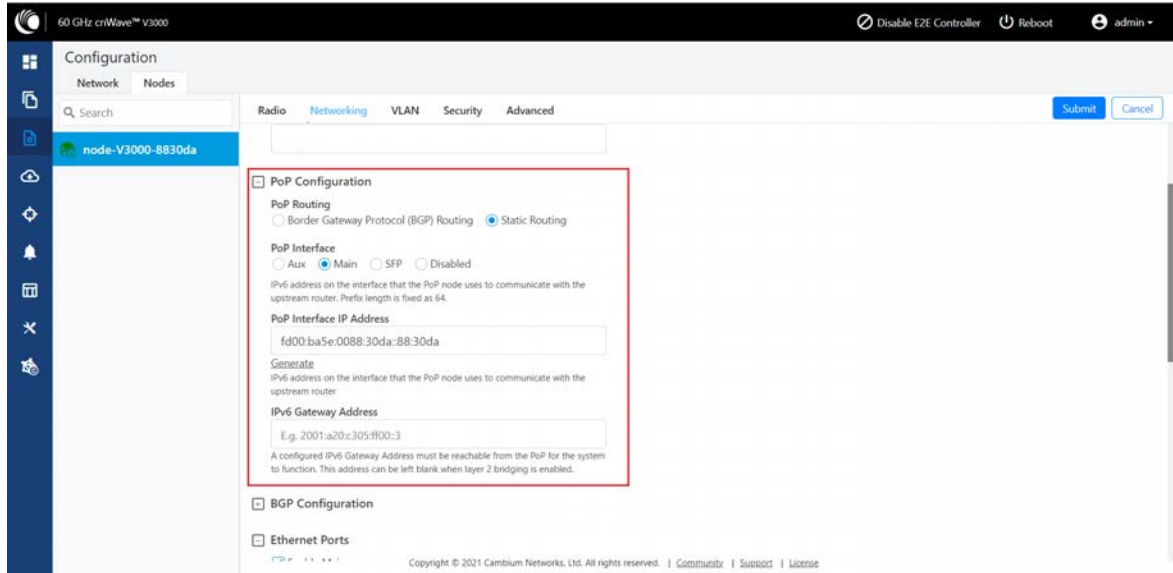

Elements	Description
PoP Routing	<p>PoP nodes connects to the upstream IPv6 router in one of the two ways:</p> <ul style="list-style-type: none"> • BGP – PoP acts as a BGP peer • Static routing – IP gateway address should be specified on the PoP and static route should be added on the upstream router. <p>When the system is targeted for L2 traffic (Layer 2 bridge enabled) and onboard controller is used, this configuration is of not much significance, recommended to set to static routing.</p>
PoP Interface	Wired interface on which PoP communicates to upstream router or switch when L2 bridge enabled.
PoP Interface IP Address	IPv6 address on the interface that the PoP node uses to communicate with the upstream router.
IPv6 Gateway Address	Gateway address. Can be left empty when L2 bridge is enabled and no IPV6 services like NTP /Radius are used.

3. Under **E2E Controller Configuration**, enter E2E IPV6 Address (Address of E2E Controller). When using onboard controller on the same node, can be left empty and GUI automatically fills the POP IPv6 address.



Note

If PoP DN is V5000/V3000 then, IPv6 both address are same.

Elements	Description
E2E IPv6 Address	Address of E2E Controller. When using onboard controller on the same node, can be left empty and GUI automatically fills the POP IPv6 address.
E2E Network Prefix	Seed Prefix in the CIDR format followed by a comma and the prefix length. Should be specified when BGP is used. Otherwise, optional.
IPv6 CPE Interface	IPv6 SLAAC provides IP prefix to downstream CPE devices. Keep it disabled when L2 Bridge is active.

4. Select required BGP configuration.

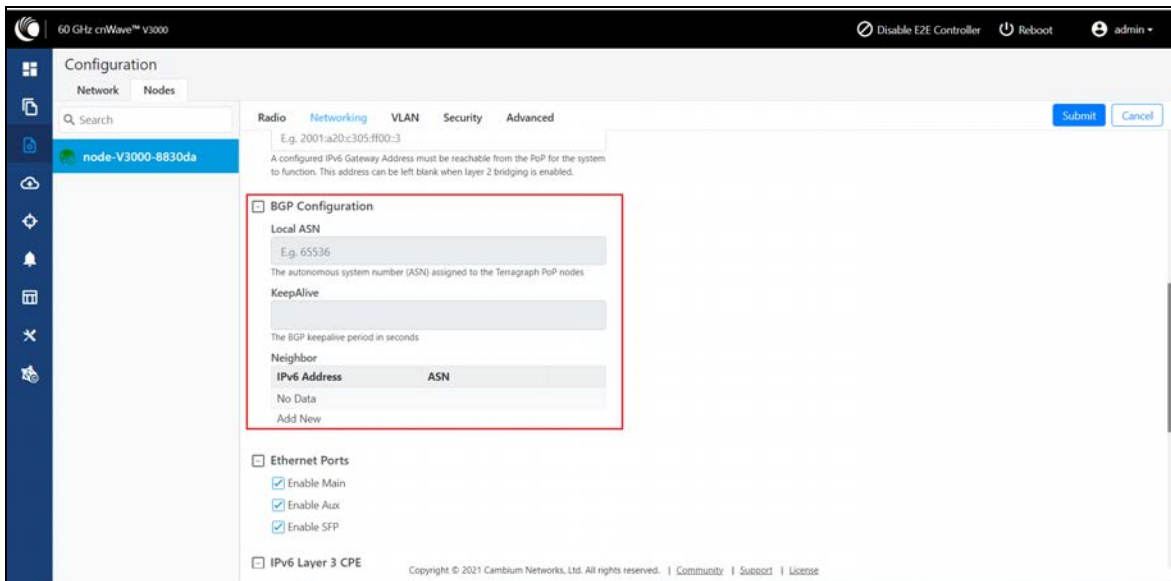

Elements	Description
Local ASN	Local ASN
Neighbour ASN	Upstream router's ASN
Neighbour IPv6	Upstream router's IPv6 address
Specific Network prefixes	Specific allocated network prefixes to be advertised via BGP

5. Enable the required Ethernet ports. Individual Ethernet ports can be turned off with this configuration.

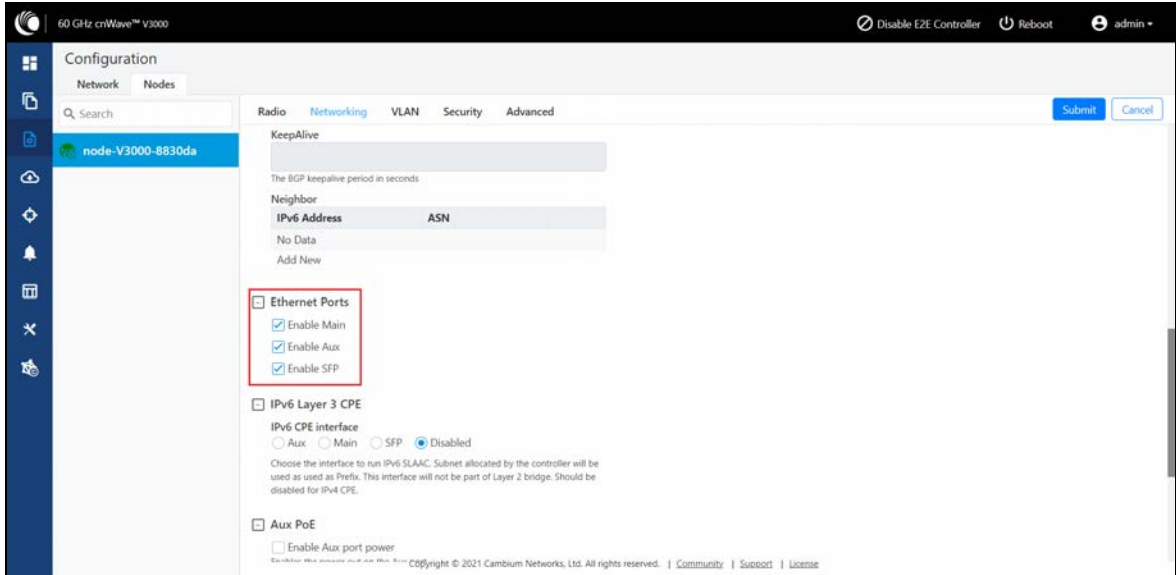

6. Select the required options for **Layer 2 Bridge**, **IPv6 Layer 3 CPE**, **AuX PoE** (enable to power on AuX port) and **Multi-PoP / Relay Port**. By default this option is disabled and PoP floods any unknown unicast ingress packets on all the L2GRE tunnels. When the option is enabled, PoP drops such packets.

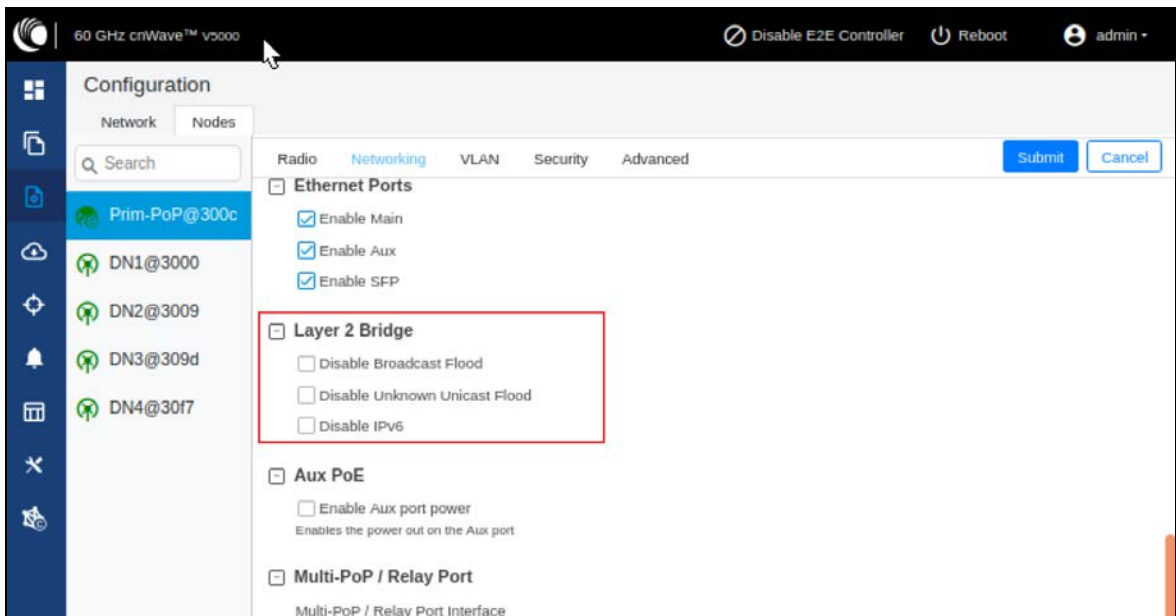

Elements	Description
Layer 2 Bridge	<p>It has three options:</p> <ul style="list-style-type: none"> • Disable Broadcast Flood • Disable Unknown Unicast Flood • Disable IPv6

Elements	Description
CPE	<p>IPv6 SLAAC provides IP prefix to downstream CPE devices. Disable this if L2 bridge is active.</p> <p>Select the CPE interface:</p> <ul style="list-style-type: none"> • Aux • Main • SFP • Disabled
Aux PoE	<p>Enable PoE out (25 W) on V5000/V3000 aux port. 802.3af and 802.3at compliant devices could be powered up, passive PoE devices cannot be powered up. Note that aux port cannot power another V5000/V3000.</p>
Relay Port	<p>Specify the Ethernet interfaces on which OpenR is running. Its needed in two cases:</p> <ul style="list-style-type: none"> • When DNs are connected back to back • When multiple PoPs are in the network. This allows PoP nodes to forward traffic to other PoP nodes via a wired connection when the routing path of the other PoP node is closer to the traffic's destination.

Out of Band (OOB) interface

Out of band management interface to access the device. Management VLAN is bypassed and data traffic will not be routed or bridged on this interface. OOB management interface is supported at PoP. A separate IPv4 address should be configured by bypassing the Management VLAN. Navigate to **Configuration > Nodes > Networking > OOB** and select the required option. Enter the IPv4 address and Subnet Mask to access the device.

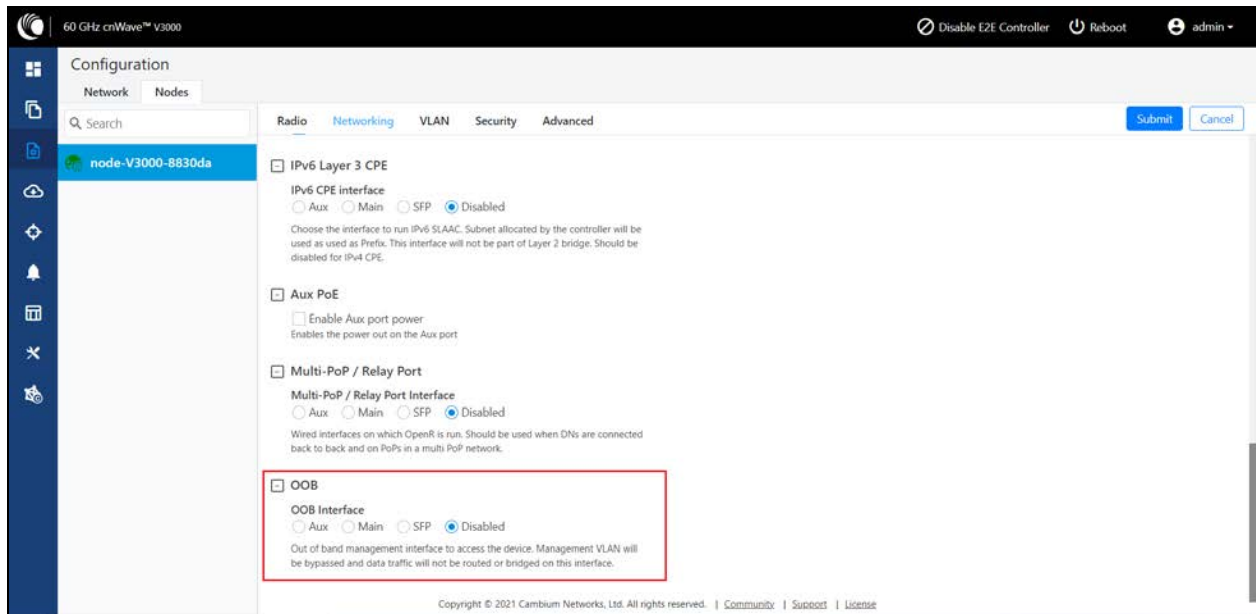

VLAN tab

Data VLAN

The following 802.1Q features are supported per port

- Adding single VLAN tag to untagged packets
- Adding QinQ/double-tag to untagged packets
- Adding QinQ outer tag to single tagged packets
- Transparently bridge single/double tagged packets (default behaviour)
- Remarking VLAN ID
- Remarking 802.1p priority
- Option to allow only the selected range of VLAN IDs
- Option to drop untagged packets
- Option to drop single tagged packets
- Option to select ethertype of the outer tag

These options are per ethernet port.



Note:

VLAN configuration is applicable only when Layer2 bridge is enabled.

Port Type

Type
<input type="radio"/> Q
<input type="radio"/> QinQ
<input checked="" type="radio"/> Transparent

Transparent

By default, ethernet port is in transparent mode. Packets will be transparently bridged without any 802.1Q processing.

Q

Q mode allows adding single C-VLAN tag to untagged packets.

Native VLAN ID
<input type="text" value="23"/>
Allowed range is 1 - 4094
Native VLAN Priority
<input type="text" value="2"/>
Allowed range is 0 - 7

Native VLAN ID and priority fields define the C-VLAN tag properties.

Allowed VLANs

List of allowed VLANs. Comma separated, and/or range. e.g 100, 210-220. Filter based on outer tag.

Allow only the listed range of VLAN IDs.

Untagged Packets

Allow Drop

This option allows to drop untagged packets. Native VLAN properties are not necessary to fill when untagged packets are dropped.

QinQ

QinQ mode allows adding double tag to untagged packets and outer S-VLAN to single tagged packets.

Native C-VLAN ID

Allowed range is 1 - 4094

Native C-VLAN Priority

Allowed range is 0 - 7

These are C-VLAN tag properties of added tag.

Native S-VLAN ID

Allowed range is 1 - 4094

Native S-VLAN Priority

Allowed range is 0 - 7

These are S-VLAN tag properties of the added outer tag.

Untagged Packets

Allow Drop

Single Tagged Packets

Allow Drop

In QinQ mode, the above options allow to drop untagged/single tagged ingress packets. Native C-VLAN fields are not necessary only when dropping single tagged packets. Native S-VLAN fields are not necessary when dropping untagged and single tagged packets.

Allowed VLANs

2

List of allowed VLANs. Comma separated, and/or range. e.g 100, 210-220. Filter based on outer tag.

Allow only the listed range of VLAN IDs. VLAN ID of the outer tag is used for this check.

QinQ EtherType

0x8100 (802.1Q)

EtherType indicates which protocol is encapsulated in the payload of an Ethernet Frame.

QinQ EtherType is used while adding outer tag. There are no other checks for EtherType.

VLAN ID remarking

VLAN Remarking

Ingress VLAN	Remark VLAN	
10	100	 

[Add New](#)



VLAN ID of the ingress packet is remarked. In the above example, if a packet with VLAN ID 10 enters ethernet port, it is remarked to 100. In the egress path, the reverse remarking occurs. VLAN ID 100 is remarked to 10 and egresses the ethernet port.

The VLAN ID of the outer tag is used for remarking. For a double tagged packet, S-VLAN ID gets remarked and for a single tagged packet, C-VLAN ID.

802.1p overriding

Priority field in the (outer) VLAN tag of ingress packet can be overwritten using this option.

VLAN Priority Override

Ingress VLAN	Override Priority	
20	7	 

[Add New](#)

Priority field in the (outer) VLAN tag of ingress packet can be overwritten using this option.

Management VLAN

A Single tag or double tag can be added to Management traffic.

Management

Enabled Disabled

VLAN ID

2

Allowed range is 1 - 4094

VLAN Priority

1

Allowed range is 0 - 7

Add Outer Tag

S-VLAN ID

3

Allowed range is 1 - 4094

S-VLAN Priority

2

Allowed range is 0 - 7

Security tab

In **Security** tab, enter **Private key password** and **Radius user password**.

- Private key password
- Radius user password

60 GHz cnWave™ V3000

Disable E2E Controller Reboot admin

Configuration

Network Nodes

Q Search

node-V3000-8830da

Radio Networking VLAN Security Advanced

Submit Cancel

Radius user identity

cambium

Private key password

Radius Private key password

Radius user password

Radius user password

Copyright © 2021 Cambium Networks, Ltd. All rights reserved. | Community | Support | License

Figure 13: Security tab

Controller GUI configuration

This Controller GUI configuration to be made on each DN.

Configuration

Network Nodes

Search

POP

DN

Radio Networking VLAN **Security**

Radius user identity
test

Private key password
.....

Radius Private key password

Radius user password
.....

Radius user password

Node GUI configuration

Private key password
.....

Radius Private key password

Radius server shared secret
.....

Radius user password

Radius user password

CA Certificate
ca.pem Browse

Certificates sent by radius server are verified against this CA certificate

Client Certificate
client.pem Browse

Private key with which client will encrypt

Client Private Key
client.key Browse

Private key with which client will decrypt



Note

Both the configurations are important for a successful authentication.

RADIUS Server configuration

Any RADIUS server can be used for the authentication. Perform the following steps to configure the RADIUS Server:

1. Ensure RADIUS packets from IPv6 subnet (i.e., lo IP subnet is accepted in RADIUS configuration).
2. Configure EAP-TLS for RADIUS Server and setup server certificate, key.



Note

Server certificate is signed by CA uploaded in node configuration.

3. Set the the CA certificate which signed the client certificate installed on each node.

Advanced tab

These settings are for the advanced users only.



Caution

Users are not recommended to do these settings.

Field	Status	Value
logTailParams.sources.terragraph_openr_logs.filename	set	/var/log/openr/current
logTailParams.sources.terragraph_openr_logs.enabled	set	true
logTailParams.sources.terragraph_kern_logs.filename	set	/var/log/kern.log
logTailParams.sources.terragraph_kern_logs.enabled	set	true
logTailParams.sources.terragraph_minion_logs.enabled	set	true
logTailParams.sources.terragraph_minion_logs.filename	set	/var/log/e2e_minion/current
popParams.POP_IFACE	modified	nic2
popParams.VPP_ADDR	unset	
popParams.POP_STATIC_ROUTING	modified	1
popParams.NAT64_POP_ENABLED	set	0
popParams.POP_BGP_ROUTING	modified	0

Figure 14: Advanced tab

Configuration options under **Network > Advanced** and **Node > Advanced** are for advanced users who understand the cnWave configuration model well. It is not recommended to use these options. Shows the merged configuration from Base layer till Network override layer.

cnWave is based on Facebook's Terragraph architecture. It follows a layered configuration model, with a node's "full" configuration computed as the union of all layers in the following order:

- **Base configuration** - The default configuration, which is tied to a specific software version and is included as part of the image. The controller finds the closest match for a node's software version string, and falls back to the latest if no match was found.

- **Firmware-specific base configuration** - The default configuration tied to a specific firmware version, which is also included as part of the image. Values are applied on top of the initial base configuration layer.
- **Hardware-specific base configuration** - The default configuration tied to a specific hardware type, which is also included as part of the image. Each hardware type supplies configuration that changes with software versions. Values are applied on top of the firmware base configuration layer.
- **Automated node overrides** - Contains any configuration parameters for specific nodes that were automatically set by the E2E controller.
- **Network overrides** - Contains any configuration parameters that should be uniformly overridden across the entire network. This takes precedence over the base configuration and automatic overrides.
- **Node overrides** - Contains any configuration parameters that should be overridden only on specific nodes (e.g. PoP nodes). This takes precedence over the network overrides.

The E2E controller manages and stores the separate configuration layers. cnWave nodes have no knowledge of these layers, except the base configuration on the image. The nodes copies the latest base version (via natural sort order) if the configuration file on disk is missing or corrupt.

Click **Submit** to apply the changes.

Chapter 7: Operation

Software upgrade

Software Upgrade menu page is used to upgrade the installed software. This page contains three tabs:

- **Node Upgrade** - to upgrade the node
- **Images** - to upgrade the software images
- **Node Upgrade Status** - displays the upgrade status

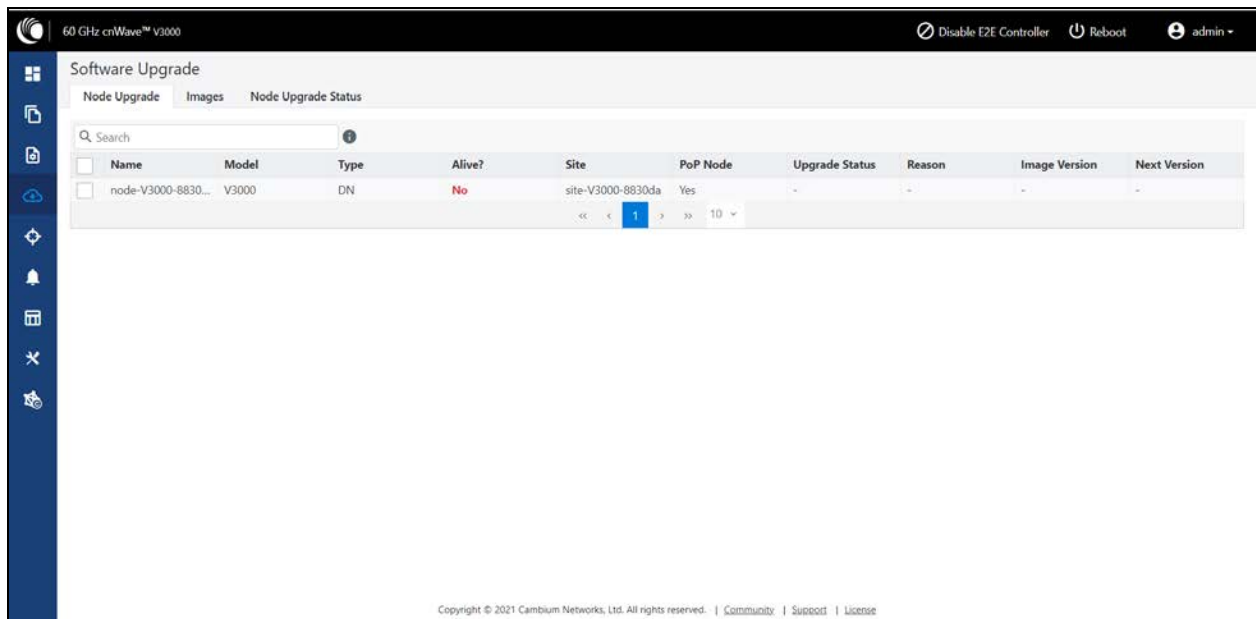
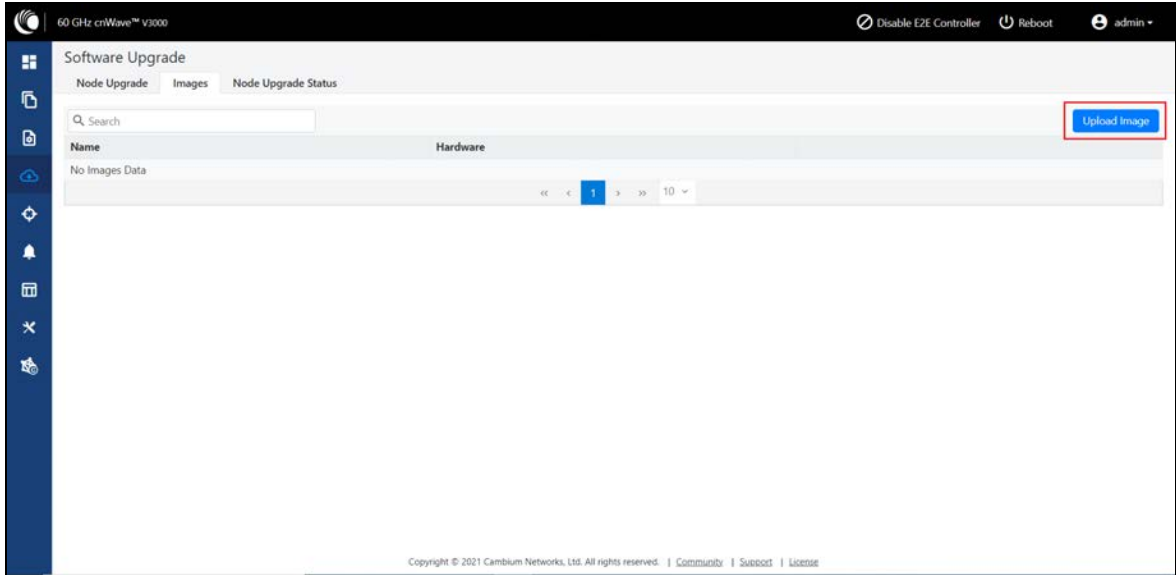

Figure 1: Software Upgrade menu

To upgrade the node, perform the following steps:

1. Click **Image > Upload Image**, browse and select the software image or package (**cnWave60-<release>.tar.gz**).



After selecting the software image, upload status is displayed.

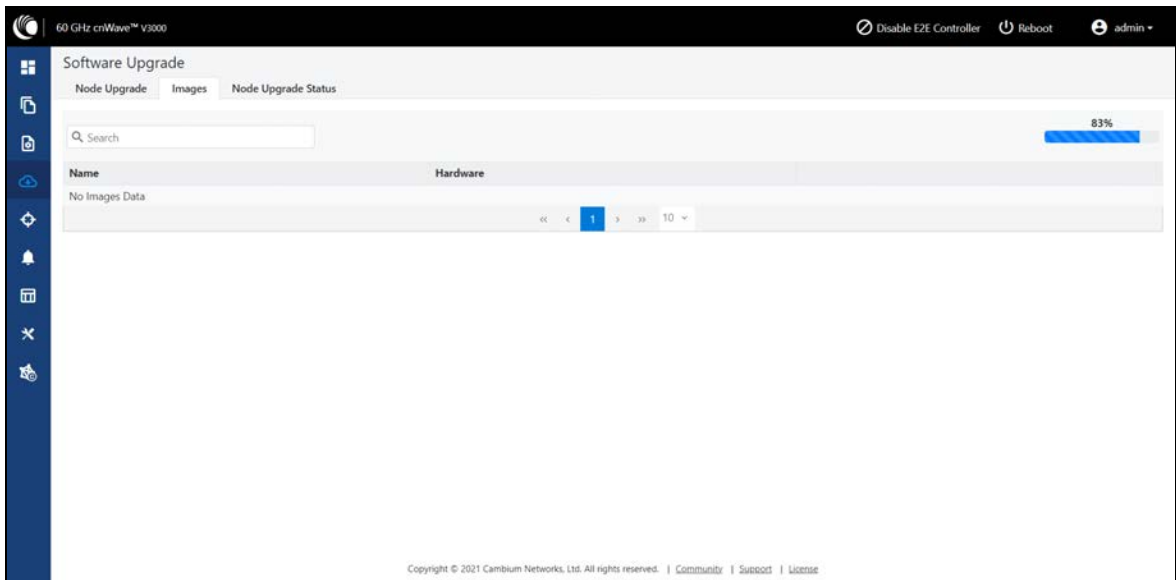

Pop-up message is displayed after the upload.

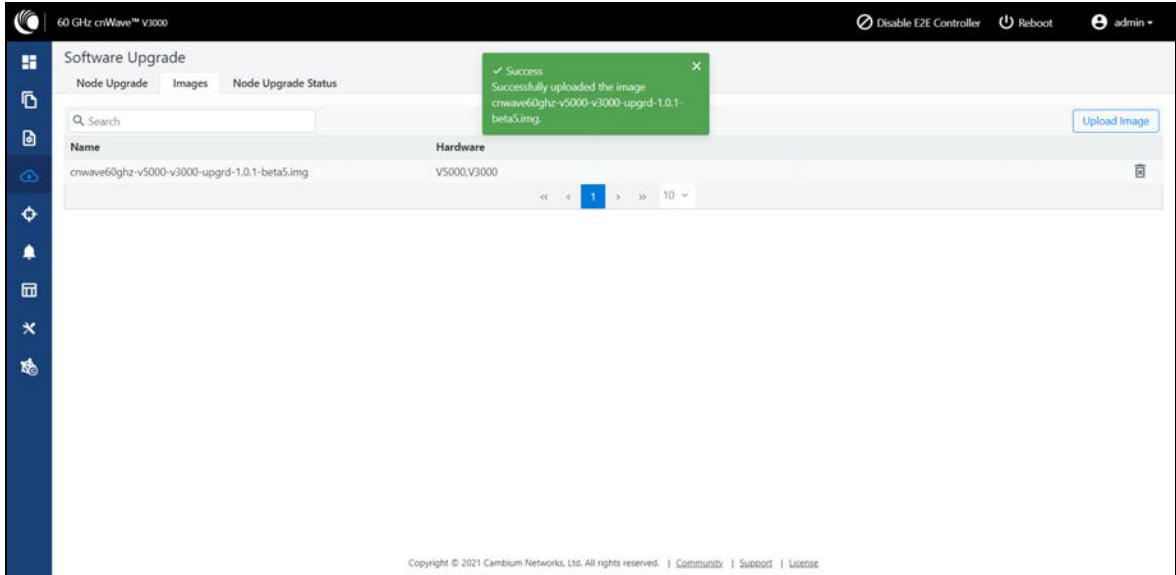

2. Click **Node Upgrade**, Select the device and click **Prepare**.

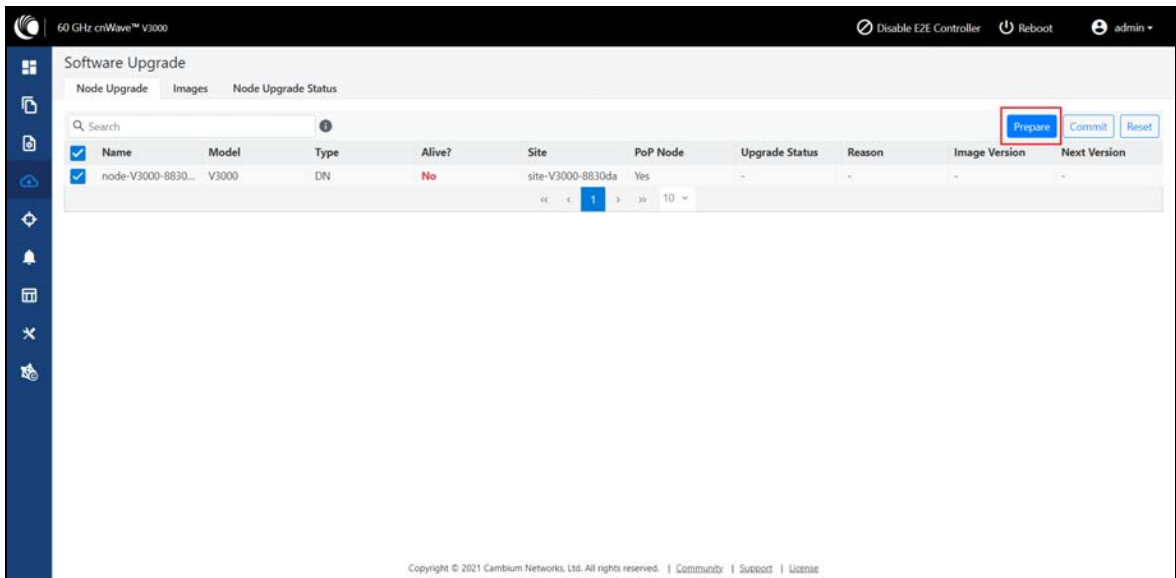

3. Select the required nodes to upgrade and click **Commit**.

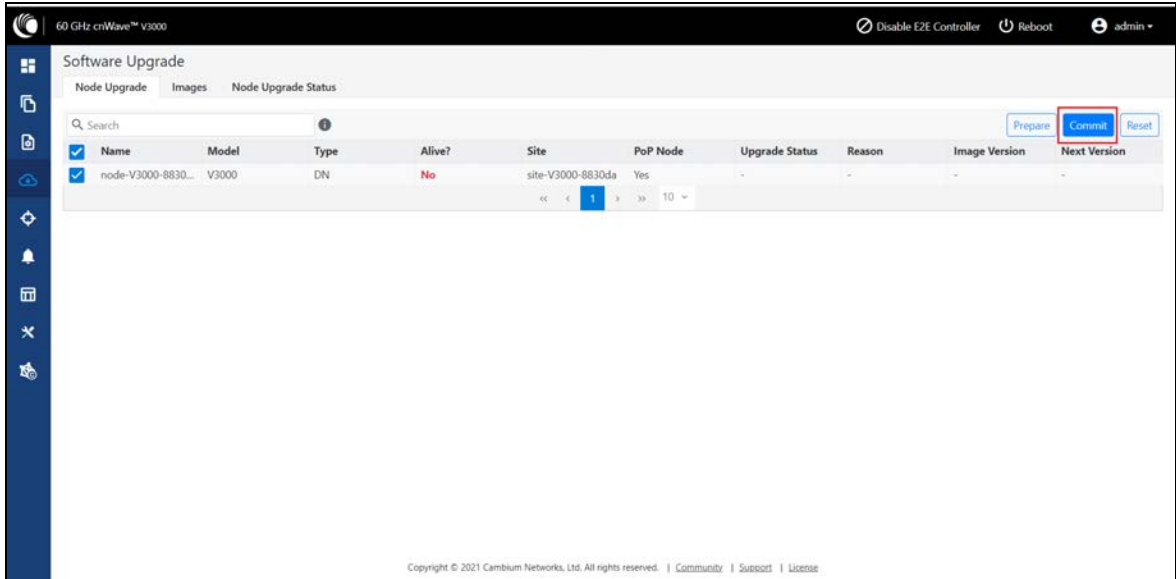

4. Select the **Upgrade Image**, enter the required information and click **Save**.

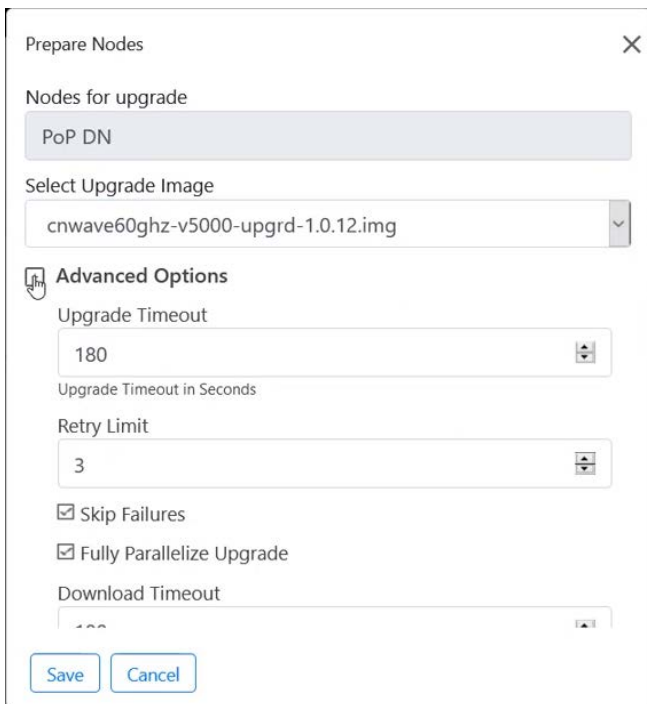

5. Click **Commit** to upgrade the software.

Click **Node Upgrade Status** to view the upgrade status.

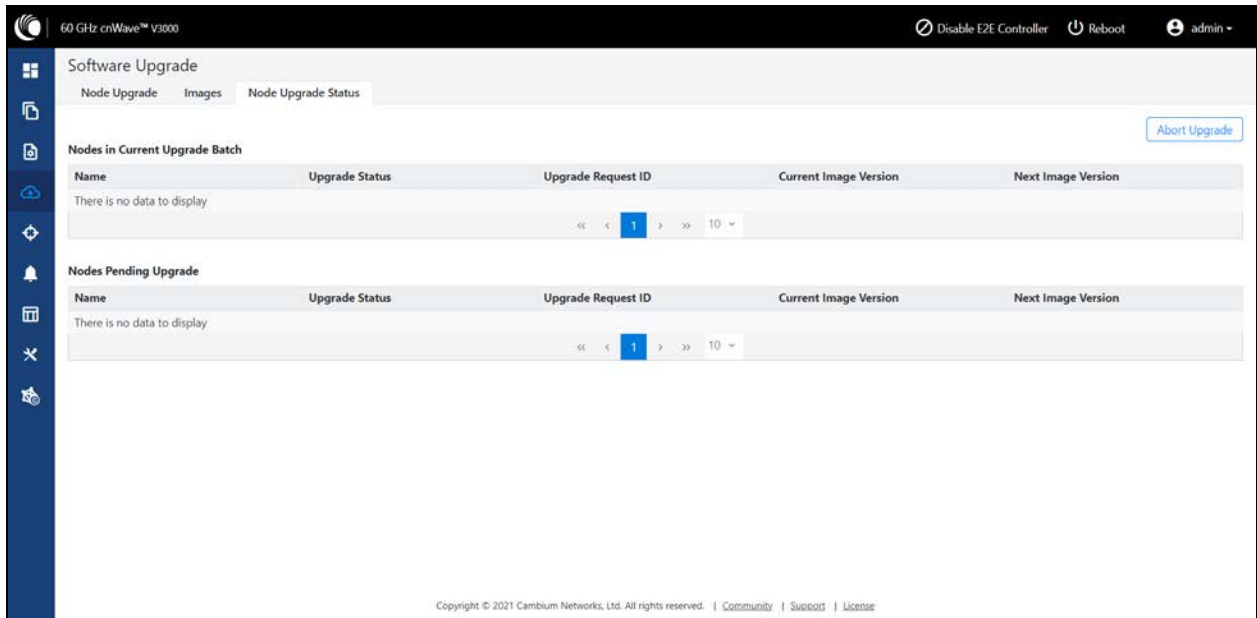

Figure 2: Node Upgrade Status

Events

Events page displays the running and completed tasks list and these events can be exported. To export the event list click **Export**.

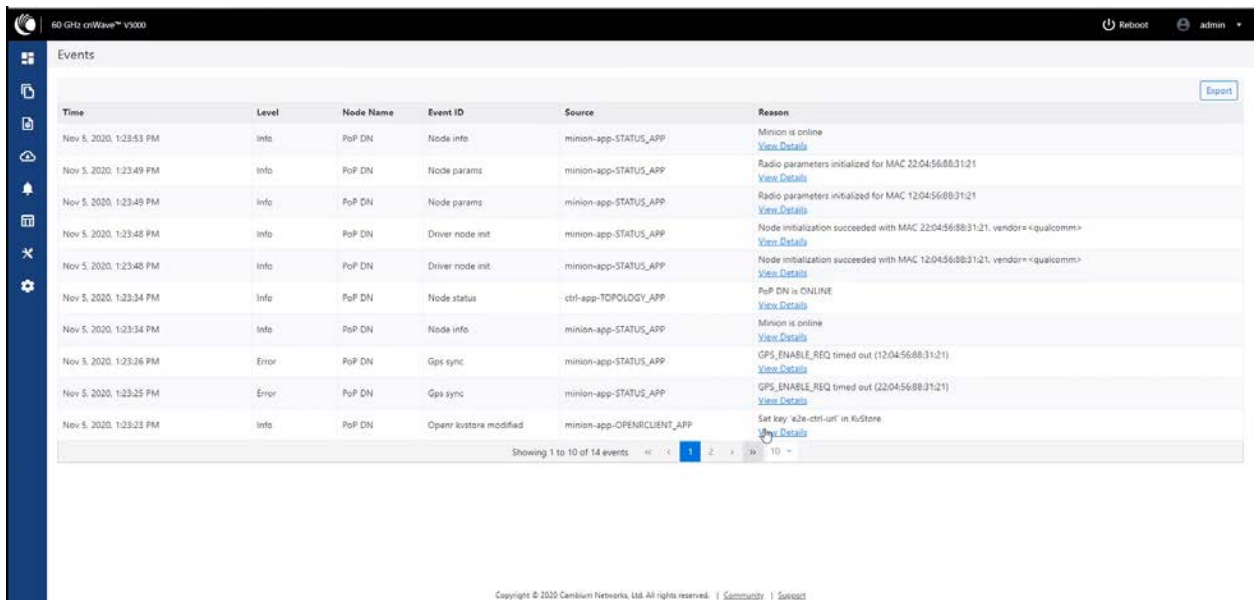

Figure 3: Events menu

Statistics

Statistics menu contains the following options:

- [Links](#)
- [Ethernet](#)
- [Ethernet](#)
- [Radio](#)
- [Performance](#)
- [Prefix Zone Statistics](#)
- [Engineering](#)
- [Border Gateway Protocol \(BGP\)](#)

Links

Link Name	A-Node	Z-Node	RSSI	SNR	MCS	TX Power Index	EIRP	RX Frames	RX Errors	RX PER	RX Beam Index	TX Frames	TX Errors	TX PER	TX Beam Index
link-DN2@PoP...	12:04:56:88:30:09	22:04:56:88:30:9d	-54	18	10	6	13	367266	31	0	94	626344	114	0	94
link-DN2@PoP...	22:04:56:88:30:9d	12:04:56:88:30:09	-54	19	10	6	13	626777	1024	0	65	367117	101	0	64
link-DN1@PoP...	12:04:56:88:30:9d	22:04:56:88:30:00	-55	18	10	6	13	712602	2	0	34	670155	0	0	34
link-DN1@PoP...	22:04:56:88:30:00	12:04:56:88:30:9d	-51	22	10	6	13	670155	0	0	114	712589	0	0	4
link-DN3@PoP...	12:04:56:88:30:f7	22:04:56:88:30:9d	-61	12	10	14	43	517810	2	0	35	403410	28	0	32
link-DN3@PoP...	22:04:56:88:30:9d	12:04:56:88:30:f7	-61	11	9	14	21	403410	51	0	92	517810	2	0	92
link-DN1@PoP...	12:04:56:88:30:00	22:04:56:88:30:0c	-53	20	10	6	13	1317337	1977	0	84	1232727	5540	0	74
link-DN1@PoP...	22:04:56:88:30:0c	12:04:56:88:30:00	-53	19	10	6	13	1241183	554	0	74	1301835	1250	0	67
link-DN2@PoP...	12:04:56:88:30:0c	22:04:56:88:30:09	-48	24	10	6	13	23446...	470437	0	45	20648...	4398564	0	35
link-DN2@PoP...	22:04:56:88:30:09	12:04:56:88:30:0c	-48	25	10	6	13	20654...	2337318	0	15	23002...	45087...	0	14

Figure 4: Links tab

Links page has Uplink and Downlink statistical data. It displays TX and RX data of the nodes from A to Z and Z to A. Links page displays the following elements:

Elements	Description
Link Name	Link name
A-Node	Initiator Node
Z-Node	Responder Node
RSSI	Receiver Signal Strength Indicator
SNR	Signal to Noise Ratio

Elements	Description
MCS	Modulation Coded Scheme
TX Power Index	Transmitter power index
RX Frames	Receiver frames
RX Errors	Receiver errors
RX PER	Receiver packer error rate
RX Beam Index	Receiver beam index
TX Frames	Transmitter frames
TX Errors	Transmitter errors
TX PER	Transmitter packer error rate
TX Beam Index	Transmitter beam index

Ethernet

Device Name	Device Model	Status	RX Packets	TX Packets	RX Bytes	TX Bytes	RX Errors	TX Errors	RX Dropped	TX Dropped	RX PPS	TX PPS	RX Throughput	TX Throughput
DN2@Po...	V5000	Down	0	0	0	0	0	0	0	0	0	0	0 kbps	0 kbps
Prim-PoP...	V5000	Down	0	0	0	0	0	0	0	0	0	0	0 kbps	0 kbps
DN1@Po...	V5000	10000 M...	1847	224256	86636	34573546	0	0	0	0	0	0	0 kbps	0 kbps
DN3@Po...	V5000	Down	0	0	0	0	0	0	0	0	0	0	0 kbps	0 kbps
DN4@Po...	V3000	Down	0	0	0	0	0	0	0	0	0	0	0 kbps	0 kbps

Figure 5: Ethernet tab

Ethernet page displays Transmitting and receiving data of the nodes. The following elements are displayed:

Elements	Description
Device Name	Name of the device
Status	Ethernet link status
RX Packets	Receiver packets
TX Packets	Transmitter packets
RX Bytes	Receiver bytes

Elements	Description
TX Bytes	Transmitter bytes
RX Errors	Receiver errors
TX Errors	Transmitter errors
RX Dropped	Receiver dropped
TX Dropped	Transmitter dropped
RX PPS	Receiver Packets Per Second
TX PPS	Transmitter Packets Per Second
RX Throughput	Receiver throughput
TX Throughput	Transmitter throughput

GPS

Device Name	MAC Address	Fix Type	Satellites tracked	Latitude	Longitude	Height
DN2@PoP2@3009	00:04:56:88:30:09	3D	17	12° 56' 2.139" N	77° 41' 39.936" E	931 m
Prim-PoP@3000_1	00:04:56:88:30:0c	3D	17	12° 56' 2.138" N	77° 41' 39.934" E	931 m
DN1@PoP1@3000	00:04:56:88:30:00	3D	17	12° 56' 2.149" N	77° 41' 39.936" E	931 m
DN3@PoP1@309D	00:04:56:88:30:9d	3D	17	12° 56' 2.138" N	77° 41' 39.935" E	932 m
DN4@PoP2@30f7	00:04:56:88:30:f7	3D	18	12° 56' 2.144" N	77° 41' 39.936" E	932 m

Figure 6: GPS tab

GPS page displays geographical data of the nodes. The following elements are displayed:

Elements	Description
Device Name	Name of the device
MAC Address	MAC address of the device
Fix Type	GPS fix type. The fix status indicates the type of signal or technique being used by the GPS receiver to determine its location. The fix status is important for the GPS consumer, as it indicates the quality of the signal, or the accuracy and reliability of the location being reported.
Satellites tracked	Number of satellites tracked

Elements	Description
Latitude	Latitude of the device
Longitude	Longitude of the device
Height	Height of the device

Radio

Device Name	MAC Address	Sync Mode	Channel	Security	Error Association	Channel Last State	RX Throughput	TX Throughput
DN2@PoP2@3009	12:04:56:88:30:09	GPS	1	PSK	0	0	2.77 kbps	2.88 kbps
DN2@PoP2@3009	22:04:56:88:30:09	GPS	3	PSK	0	0	7.58 kbps	10.80 kbps
Prim-PoP@3000_1	12:04:56:88:30:0c	GPS	3	PSK	0	0	12.49 kbps	12.29 kbps
Prim-PoP@3000_1	22:04:56:88:30:0c	GPS	1	PSK	0	0	24.69 kbps	12.99 kbps
DN1@PoP1@3000	12:04:56:88:30:00	GPS	1	PSK	0	0	10.22 kbps	21.82 kbps
DN1@PoP1@3000	22:04:56:88:30:00	GPS	4	PSK	0	0	16.47 kbps	5.40 kbps
DN3@PoP1@309D	12:04:56:88:30:9d	GPS	4	PSK	0	0	6.46 kbps	15.49 kbps
DN3@PoP1@309D	22:04:56:88:30:9d	GPS	1	PSK	0	0	11.03 kbps	4.64 kbps
DN4@PoP2@307	12:04:56:88:30:f7	GPS	1	PSK	0	0	6.83 kbps	5.58 kbps

Figure 7: Radio

Radio page displays the radio data of the nodes. This page has the following elements:

Elements	Description
Device Name	Name of the device
MAC Address	MAC address of the device
Sync Mode	<ul style="list-style-type: none"> • GPS sync: <ul style="list-style-type: none"> • <i>Entry condition:</i> Valid samples from GPS have been received for a few consecutive seconds (typically 2 seconds). • <i>Exit condition:</i> Valid samples from GPS have not been received for a few consecutive seconds (typically 10 seconds). • RF sync: Not in “GPS sync”, but is reachable to a DN with “GPS sync” over wireless links (1-2 hops away). <ul style="list-style-type: none"> • <i>Entry condition:</i> Conditions for “GPS sync” have not been met, but a link exists to at least one other DN from which to derive timing. • <i>Exit condition:</i> Conditions for “GPS sync” have not been met and no links to other DNs exist from which to derive timing. • No sync: Neither in GPS sync nor RF sync. This is the default state. <ul style="list-style-type: none"> • <i>Entry condition:</i> Conditions for “GPS sync” or “RF sync” are not met. • <i>Exit condition:</i> Condition for “GPS sync” or “RF sync” are met.

Elements	Description
Channel	Operating channel
Security	Security type
Error Association	Error Association
Channel Last State	Channel Last State
RX Throughput	Receiver throughput
TX Throughput	Transmitter throughput

Performance

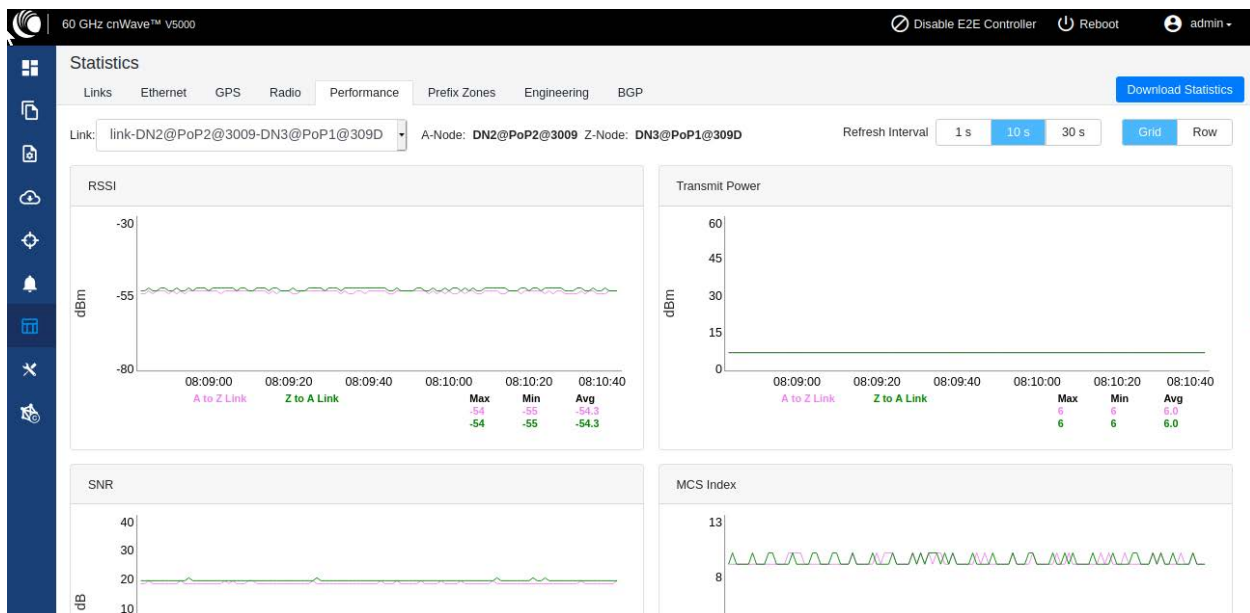

Figure 8: Performance tab

Performance page displays the performance graph. It includes the following graphs:

Elements	Description
RSSI	Receiver Signal Strength Indicator. It is a measurement of the power present in a received radio signal
Transmit Power	Transmitting power
SNR	Signal to Noise Ratio
MCS Index	Modulation and Coding Scheme (MCS) Index Values can be used to determine the likely data rate of your wireless connection. The MCS value essentially summarizes the number of spatial streams, the modulation type and the coding rate that is possible when

Elements	Description
	connecting your wireless access point.
Packet Error Ratio	Packet error ratio. It is the ratio, in percent, of the number of Test Packets not successfully received by the node to the number of Test Packets sent to the node by the test set.
Received Frames	Number of frames received at the node.
Transferred Frames	Number of frames transferred from the node.

RSSI graph

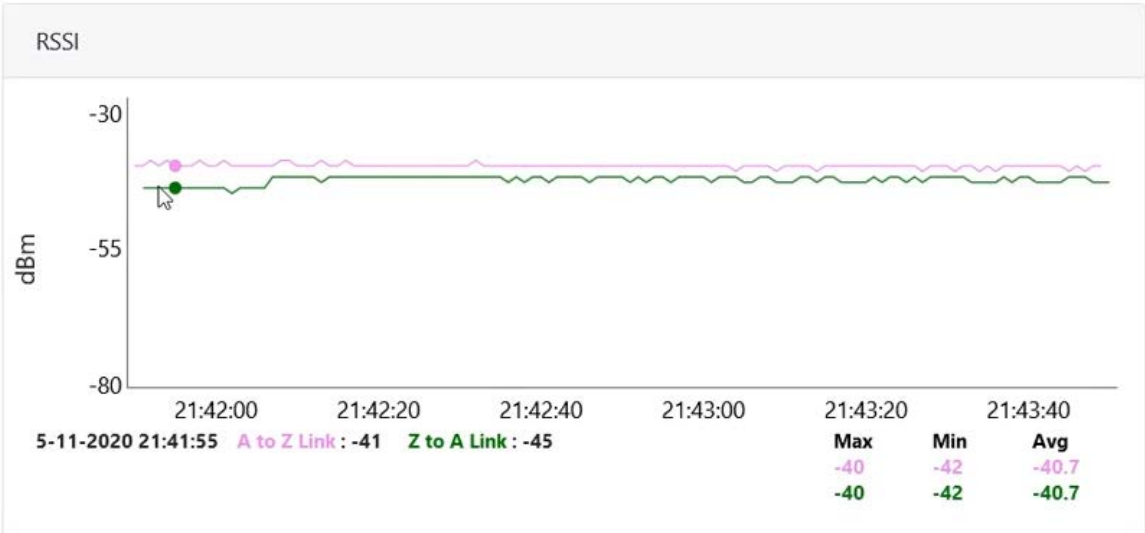

Figure 9: RSSI graph

Transmit Power graph

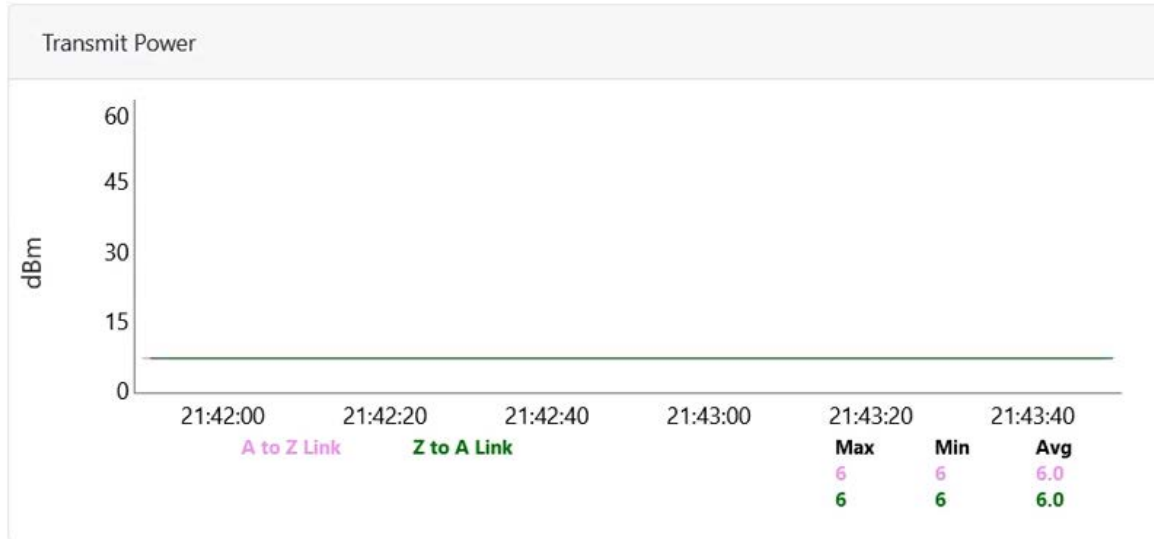

Figure 10: Transmit Power graph

SNR graph

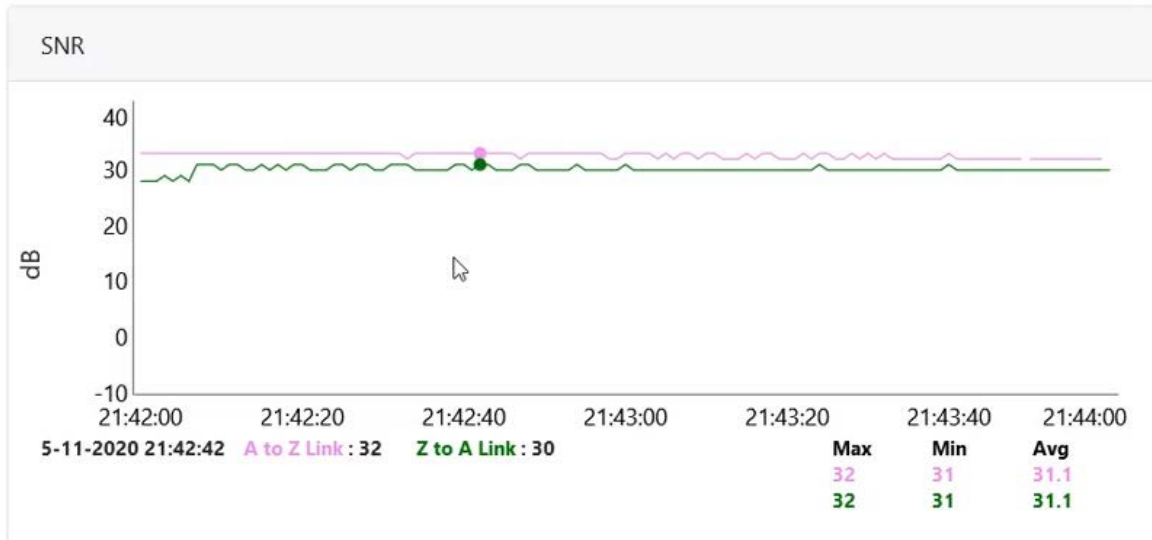

Figure 11: SNR graph

MCS Index graph

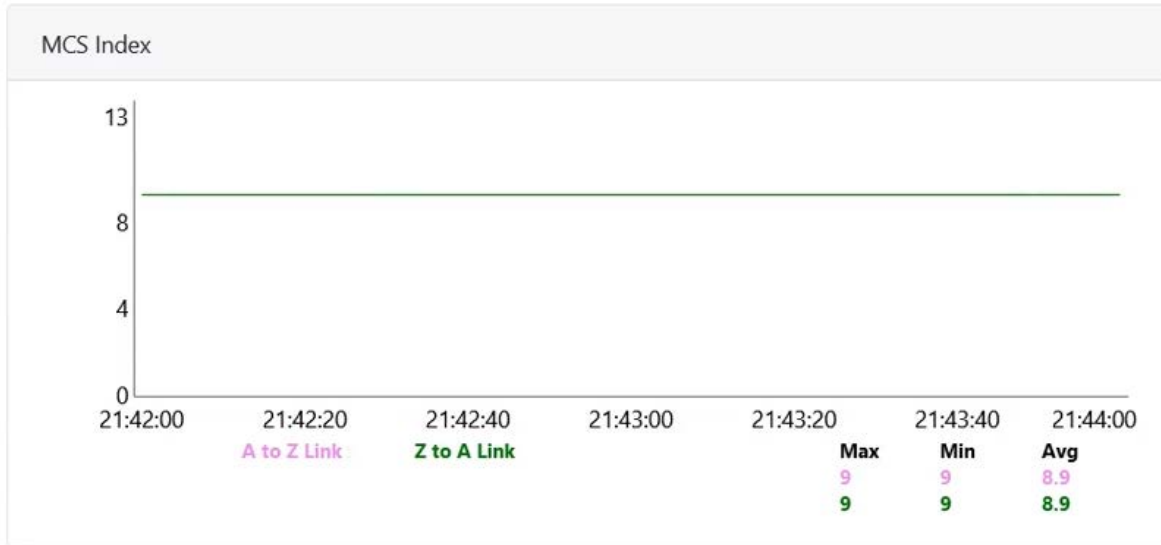

Figure 12: MCS Index graph

Packet Error Ratio graph

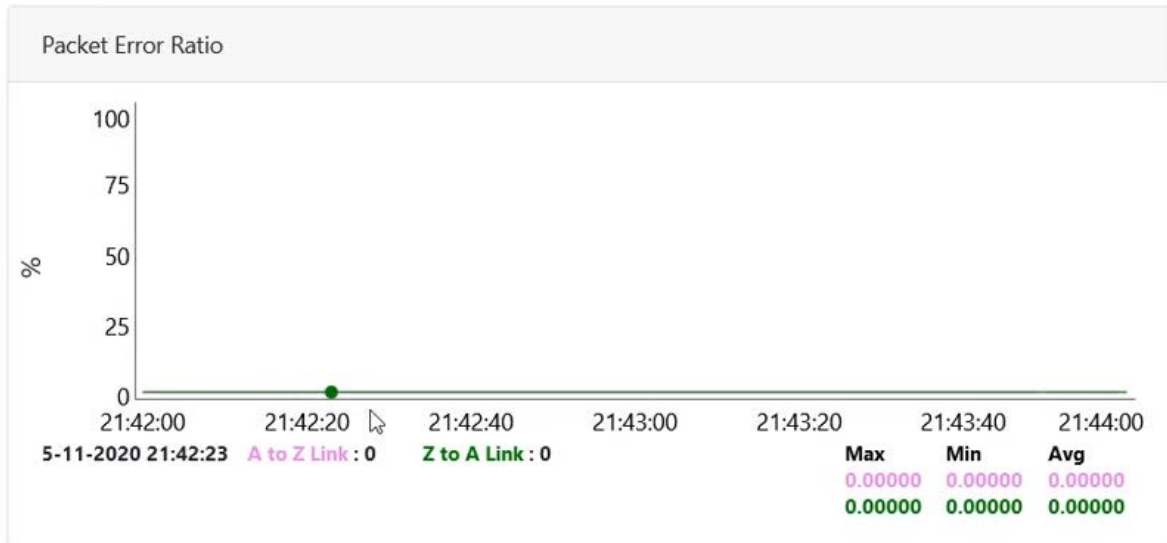

Figure 13: Packet Error Ratio graph

Received Frames graph

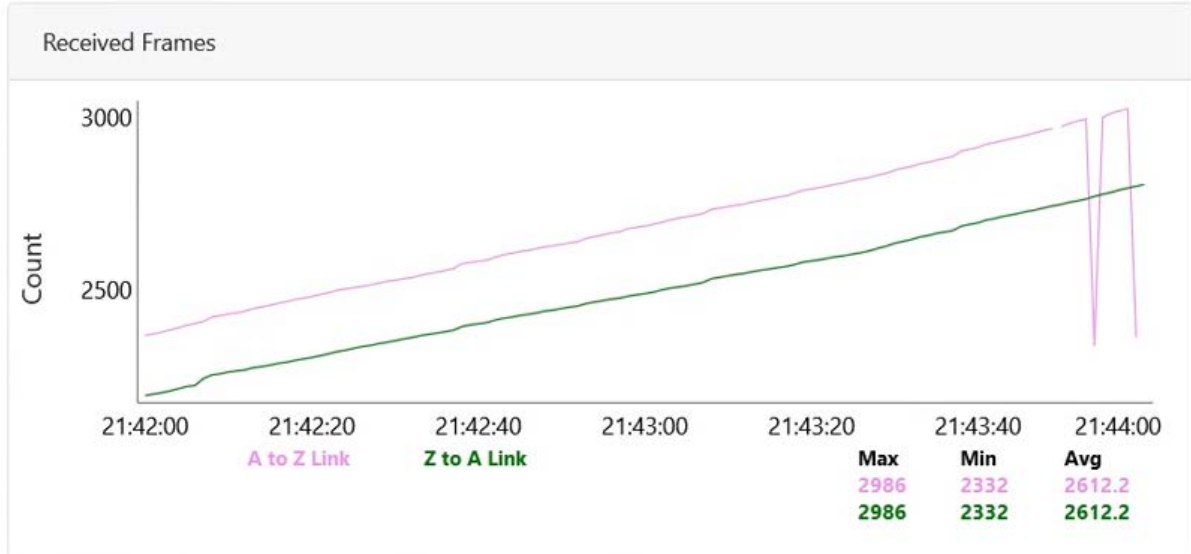

Figure 14: Received Frames graph

Transferred Frames graph

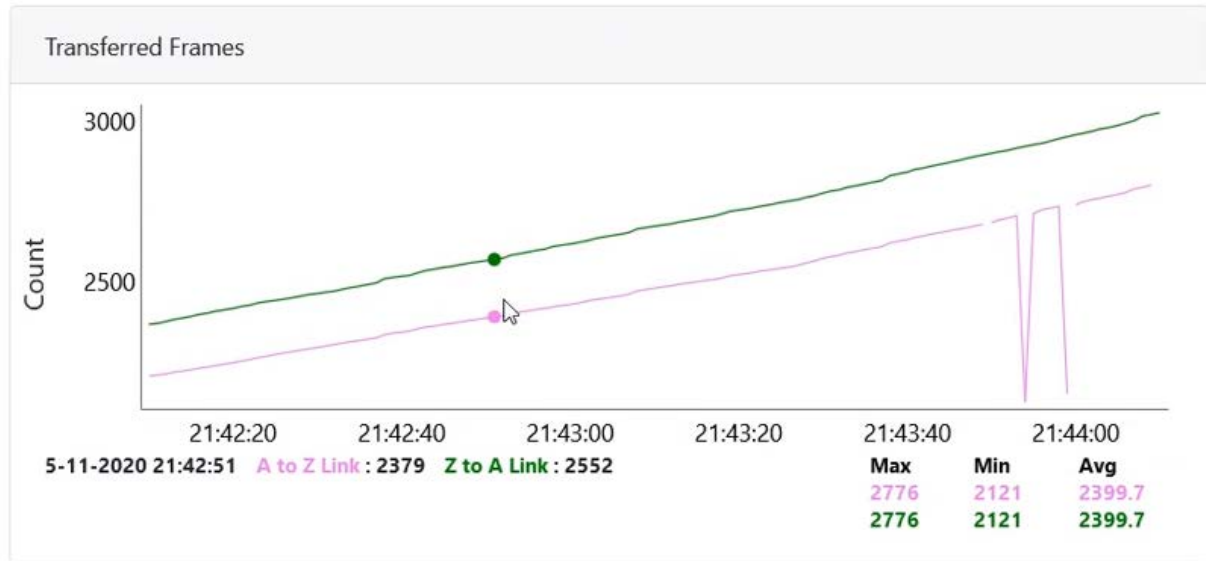
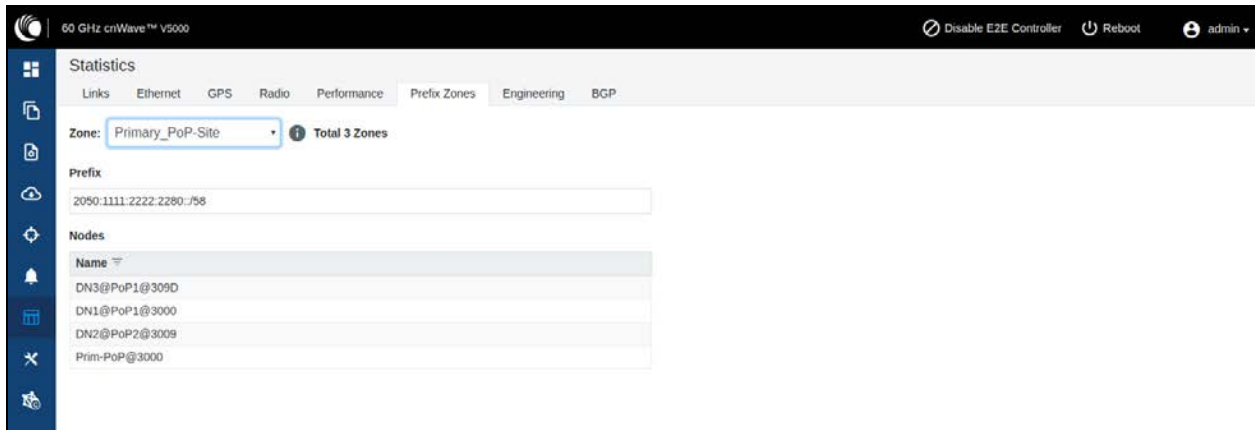

Figure 15: Transferred Frames graph

Prefix Zone Statistics

When **Deterministic prefix** is enabled and in the multi-PoP deployments, the mesh is divided into prefix zones. Prefix Zone statistics are available in **Statistics > Prefix Zone** page.



Engineering

The **Engineering** page displays the engineering information of system and sector.

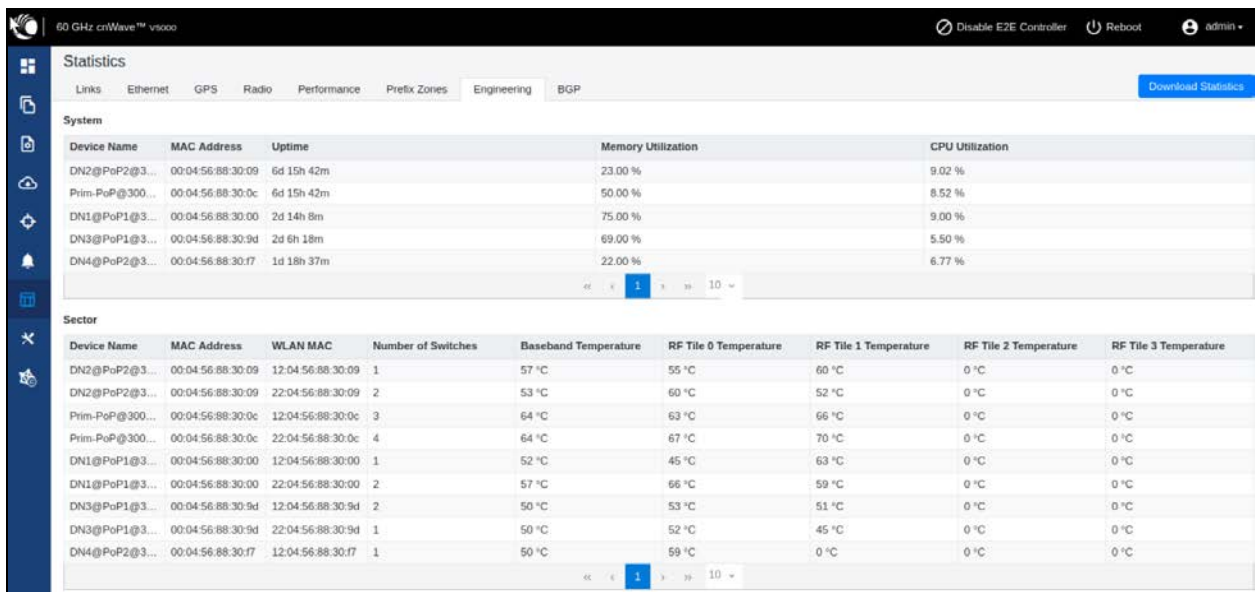

Figure 16: *Engineering* tab

Border Gateway Protocol (BGP)

The BGP is the protocol used throughout the Internet to exchange routing information between networks. It is the language spoken by routers on the Internet to determine how packets can be sent from one router to another to reach their final destination. BGP has worked extremely well and continues to be the protocol that makes the Internet work.

To configure BGP, navigate to **Statistics** and select **BGP** tab.

The screenshot displays the BGP configuration page in the cnWave V5000 interface. The page is titled "Statistics" and includes a navigation menu with options like Links, Ethernet, GPS, Radio, Performance, Prefix Zones, Engineering, and BGP. The main content is divided into two sections: "A-Sec-PoP" and "Prim-PoP@3000".

A-Sec-PoP (2021::1)

Details	
IPv6 Address	2021::1
Status	Online
ASN	65534
Uptime	0d 0h 4m

Advertised Routes		
	Network	Next Hop
1	2020:1111:2222:2200::/56	2021::100

Received Routes		
	Network	Next Hop
1	:::0	fe80::c6ad:34ff:fe45:aa00
2	2020:1111:2222:2200::/56	fe80::c6ad:34ff:fe45:aa00

Prim-PoP@3000 (2021::1)

Details	
IPv6 Address	2021::1
Status	Offline
ASN	65534
Uptime	NA

Advertised Routes		
	Network	Next Hop

Received Routes		
	Network	Next Hop
1	:::0	fe80::c6ad:34ff:fe45:aa00
2	2020:1111:2222:2200::/56	fe80::c6ad:34ff:fe45:aa00

Copyright © 2021 Cambium Networks, Ltd. All rights reserved. | [Community](#) | [Support](#) | [License](#)

Maps

Map displays the topology and location/sites of the deployed nodes in the cnWave network. Click **Maps** icon on the left panel to display the nodes.

The screenshot displays the Map page in the cnWave V5000 interface. The page is titled "Map" and includes a navigation menu with options like Links, Ethernet, GPS, Radio, Performance, Prefix Zones, Engineering, and BGP. The main content is a network topology diagram showing five nodes connected by green lines. The nodes are labeled as follows:

- Prim-PoP@30k
- DN1@3000
- DN2@3009
- DN3@309d
- DN4@30f7

The diagram shows a central node (DN1@3000) connected to Prim-PoP@30k, DN2@3009, and DN3@309d. DN2@3009 is connected to DN3@309d. DN3@309d is connected to DN4@30f7. There is also a direct connection between DN1@3000 and DN4@30f7. A "Show Names:" toggle is set to "Yes".

Copyright © 2021 Cambium Networks, Ltd. All rights reserved. | [Community](#) | [Support](#) | [License](#)

Tools

Tools menu contains **Factory Reset** and **Logs** options. Factory Reset is used to set the default settings.

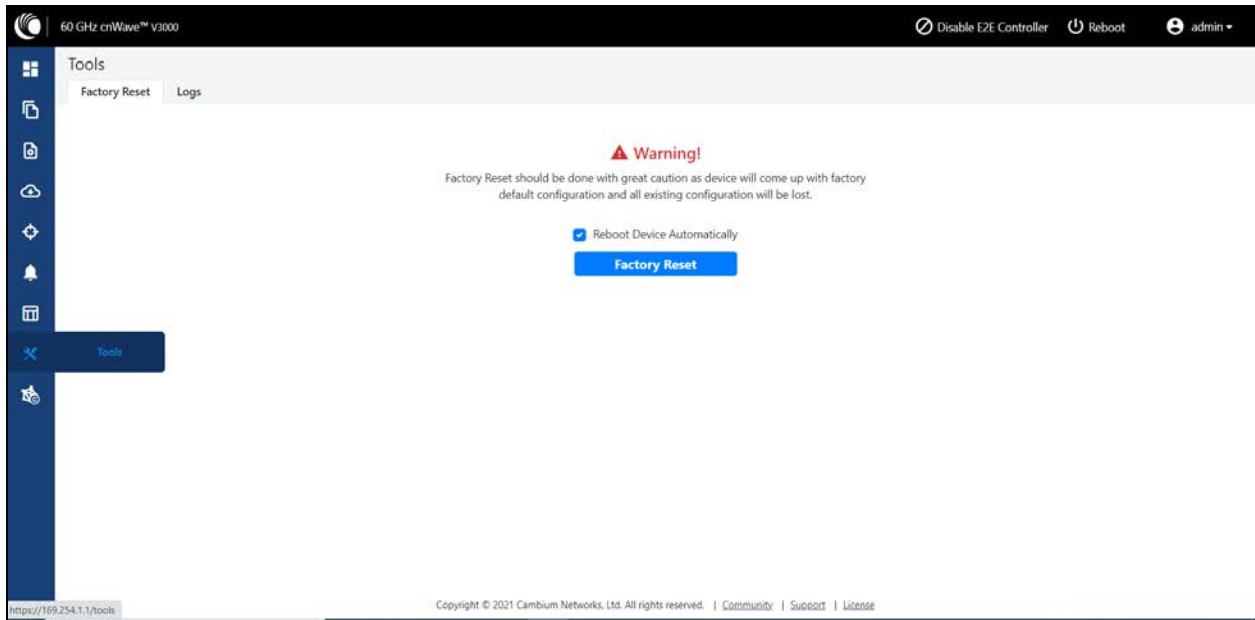

Figure 17: Tools menu

Logs tab is used to view and download the error logs. To download the error logs select the node from the drop-down and click **Download Logs**.

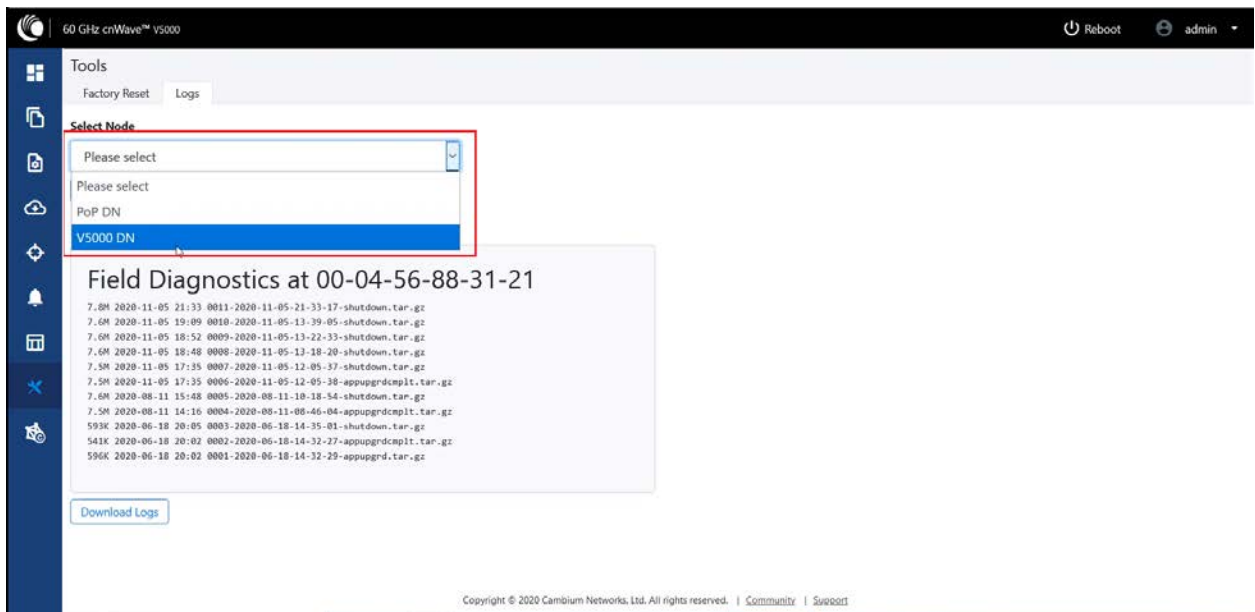

Figure 18: Logs tab

After clicking **Download Logs**, downloading status is displayed.

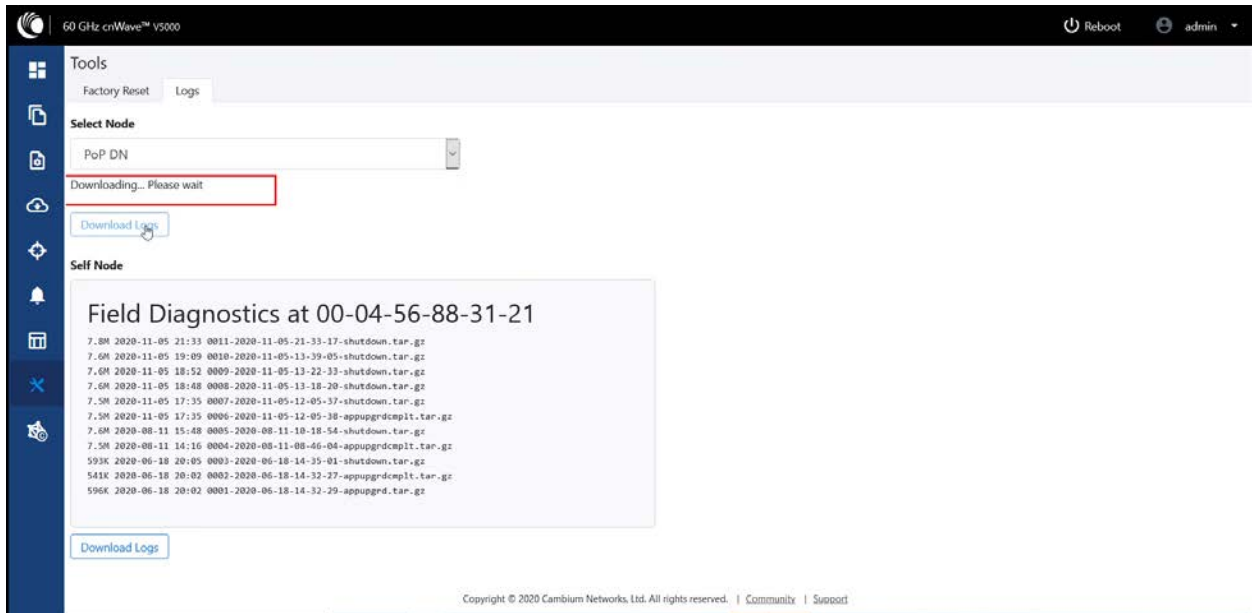

Figure 19: Download status

To download the logs for self node, click **Download Logs** at the bottom and save the log file.

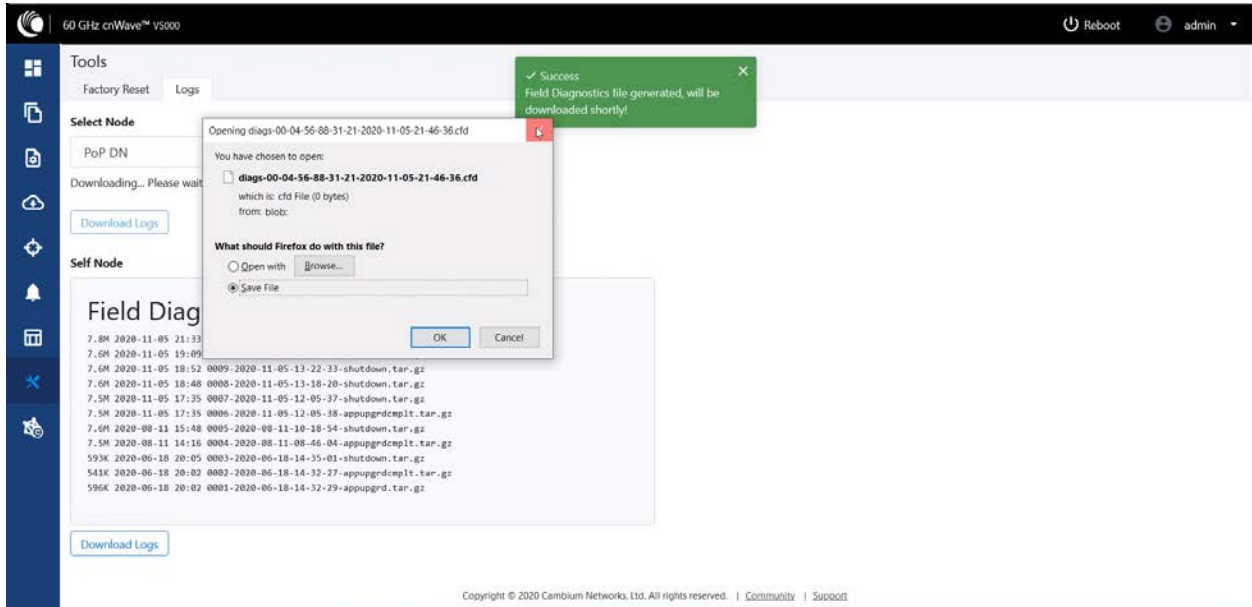
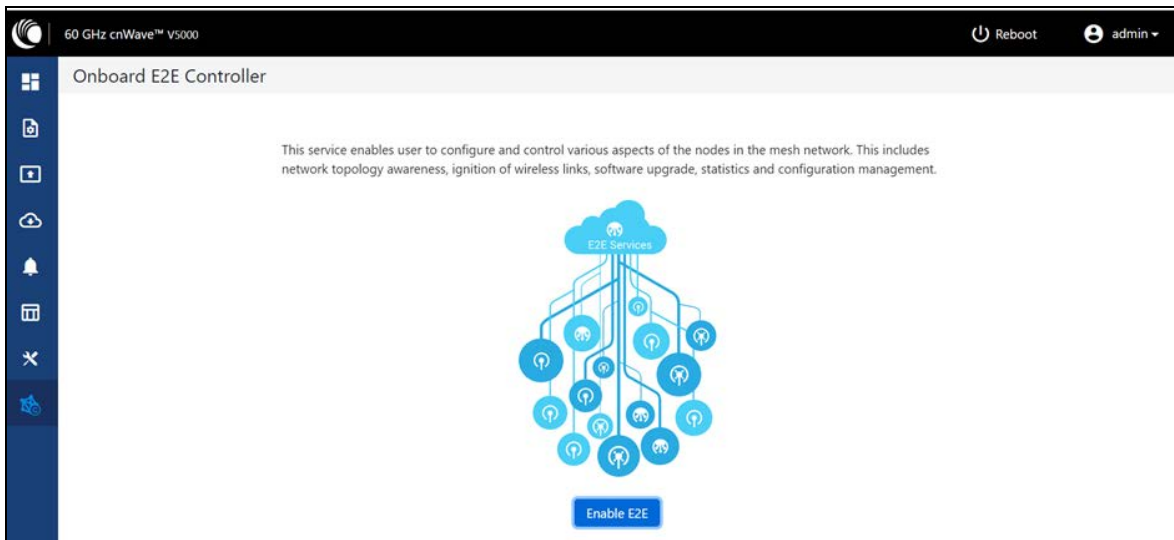

Figure 20: Saving log file

cnMaestro support for Onboard Controller

From System Release 1.0.1 onwards, Onboard E2E controller can be managed by cnMaestro 2.5.0 (on-premises) for network management.

1. After Onboard E2E controller is enabled from UI, enter cnMaestro URL. If **Cambium ID based authentication** option is enabled in cnMaestro, then enter cambium ID and onboarding key.
2. Click **Enable E2E** on **Onboard E2E Controller** in UI.



3. Enter cnMaestro management configuration information.
 - Remote Management - Select the required remote management option
 - cnMaestro URL - cnMaestro address
 - Cambium ID - Cambium ID of the device
 - Onboarding key - Password to onboard the device

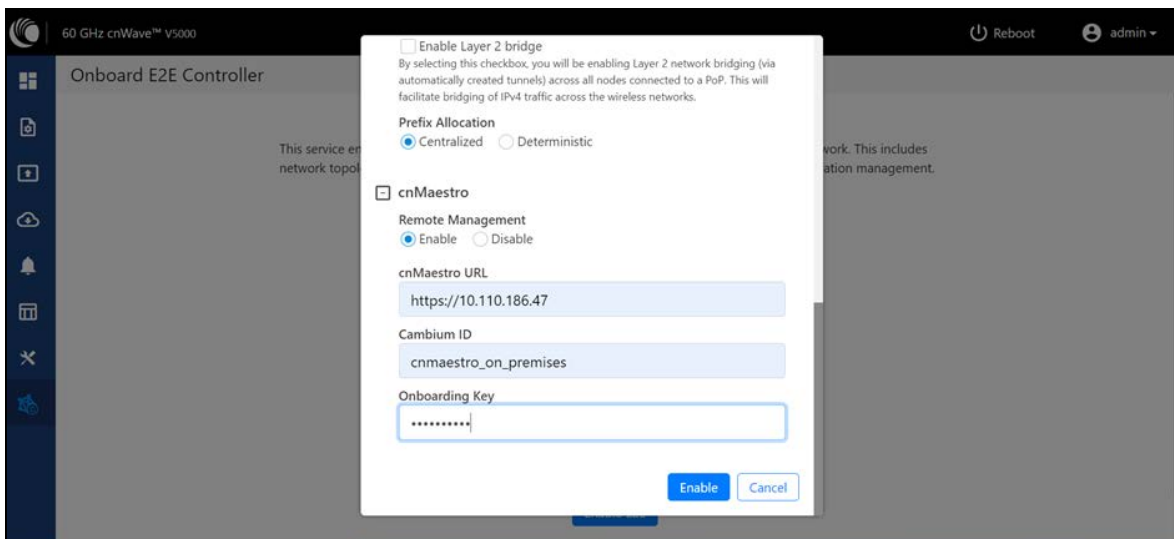

4. Click **Enable**.
5. New E2E Network appears in cnMaestro. Click **Approve** to manage it.

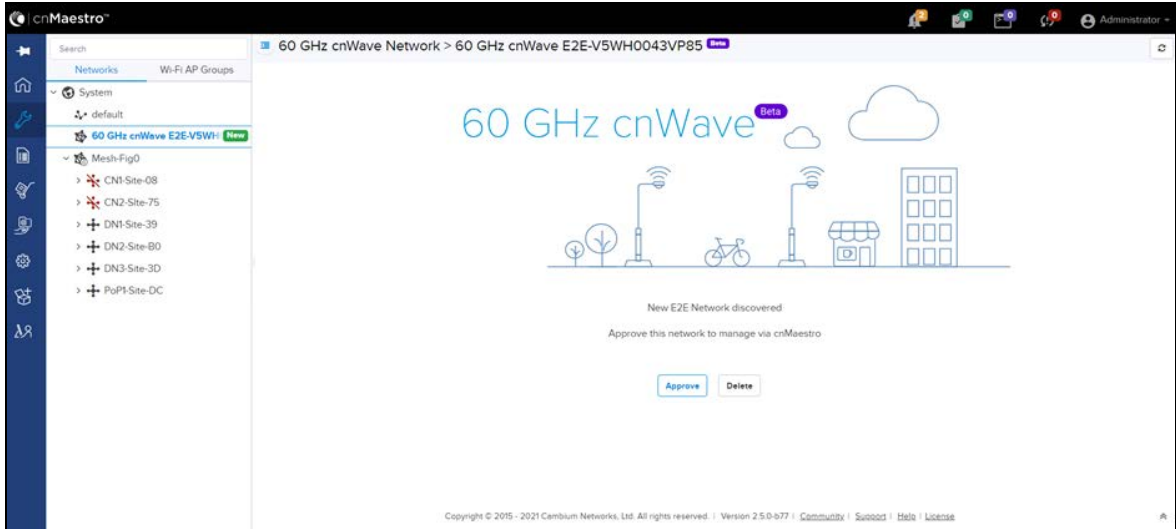

6. The **Network Onboard** window appears and provides option to edit network name.
7. Click **Save**.

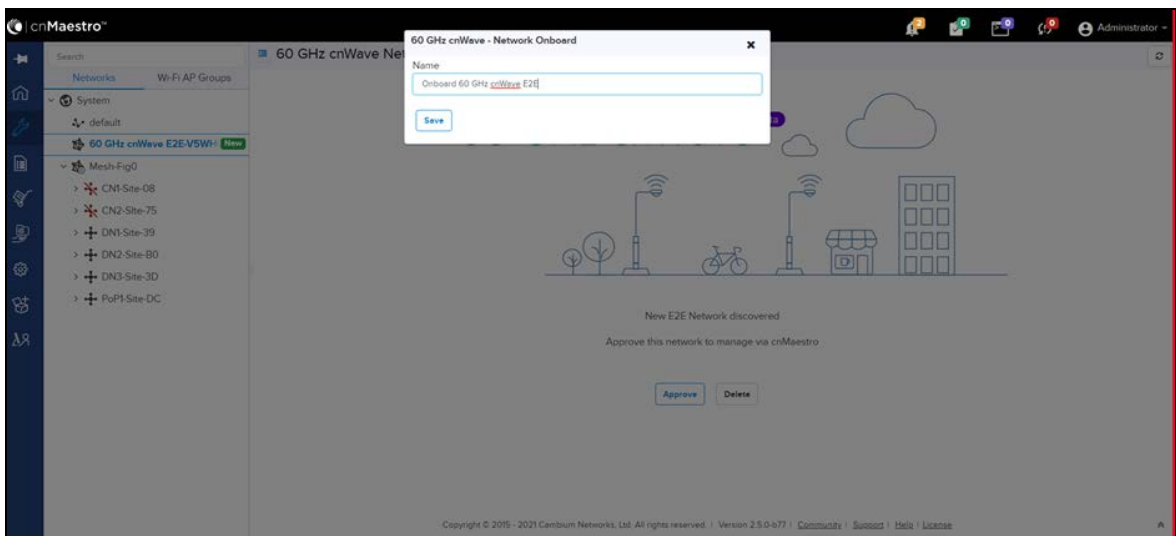

After the successful onboarding of E2E Network, it can be managed through cnMaestro.

The screenshot displays the cnMaestro interface for a 60 GHz cnWave Network. The main dashboard includes several key performance indicators (KPIs) and a map view.

Nodes	Links	Wireless Throughput of PoP(s)		Wired Throughput of PoP(s)	
Offline Last Week: 3	Total: 2	0 Kbps Tx	0 Kbps Rx	0 Kbps Tx	0 Kbps Rx
Total: 0	Offline: 0				

Alarms: 0 CRITICAL, 0 MAJOR, 0 MINOR (LAST 24 HOURS)

EZE Controller Details:

Version	1.0.1-dev79
Management Address	10.110.178.11
IPv6 Address	fd00:ba5e:0088::
IPv6 Gateway	-
Sites	3
Deployment	Running Onboard

The map view shows a network topology with three nodes (represented by green circles) connected by green lines, overlaid on a street map. Labels on the map include "57th School Rd" and "61st School Rd".

Chapter 8: Regulatory Information

This chapter provides regulatory notifications.



Caution

Intentional or unintentional changes or modifications to the equipment must not be made unless under the express consent of the party responsible for compliance. Any such modifications could void the user’s authority to operate the equipment and will void the manufacturer’s warranty.



Attention

Les changements ou modifications intentionnels ou non intentionnels à l'équipement ne doivent pas être effectués sauf avec le consentement exprès de la partie responsable de la conformité. De telles modifications pourraient annuler l'autorisation de l'utilisateur à faire fonctionner l'équipement et annulera la garantie du fabricant.

The following topics are described in this chapter:

- Compliance with safety standards lists the safety specifications against which the 60 GHz cnWave™ family of ODUs has been tested and certified. It also describes how to keep RF exposure within safe limits.
- Compliance with radio regulations describes how the 60 GHz cnWave™ family of ODUs complies with the radio regulations that are in force in various countries.

Compliance with safety standards

This section lists the safety specifications against which the 60 GHz cnWave™ platform family is tested and certified. It also describes how to keep RF exposure within safe limits.

Electrical safety compliance

The 60 GHz cnWave™ platform family hardware is tested for compliance to the electrical safety specifications listed in following [Safety compliance specifications](#) table.

Table 29: Safety compliance specifications

Region	Specification
USA	UL 62368-1, UL 60950-22
Canada	CSA C22.2 No.62368-1, CSA C22.2 No. 60950-22
Europe	EN 62368-1, EN 60950-22
International	CB certified IEC 62368-1 Edition 2 IEC 60950 -22

Electromagnetic Compatibility (EMC) compliance

The EMC specification type approvals that is granted for 60 GHz cnWave™ platform family are listed in following table.

Table 30:EMC compliance

Region	Specification
USA	FCC Part 15 Class B
Canada	RSS Gen
Europe/International	EN 301 489-1 V2.2.3, EN 301 489-17 V3.2.4

Human exposure to radio frequency energy

Relevant standards (USA and EC) applicable when working with RF equipment are:

- ANSI IEEE C95.1-2005, IEEE Standard for Safety Levels with Respect to Human Exposure to Radio Frequency Electromagnetic Fields, 3 kHz to 300 GHz
- Council recommendation of 12 July 1999 on the limitation of exposure of the general public to electromagnetic fields (0 Hz to 300 GHz) (1999/519/EC) and respective national regulations
- *Directive 2013/35/EU - electromagnetic fields* of 26 June 2013 on the minimum health and safety requirements regarding the exposure of workers to the risks arising from physical agents (electromagnetic fields) (20th individual Directive within the meaning of Article 16(1) of Directive 89/391/EEC) and repealing Directive 2004/40/EC.
- US FCC limits for the general population. See the FCC web site at <http://www.fcc.gov>, and the policies, guidelines, and requirements in Part 1 of Title 47 of the Code of Federal Regulations, as well as the guidelines and suggestions for evaluating compliance in FCC OET Bulletin 65
- Health Canada limits for the general population. See the Health Canada web site at <https://www.canada.ca/en/health-canada/services/environmental-workplace-health/consultations/limits-human-exposure-radiofrequency-electromagnetic-energy-frequency-range-3-300.html> and [Safety Code 6](#)
- EN 62232: 2017 Determination of RF field strength, power density and SAR in the vicinity of radiocommunication base stations for the purpose of evaluating human exposure (IEC 62232:2017)
- EN 50385:2017 Product standard to demonstrate the compliance of base station equipment with radiofrequency electromagnetic field exposure limits (110 MHz - 100 GHz), when placed on the market
- ICNIRP (International Commission on Non-Ionizing Radiation Protection) guidelines for the general public. See the ICNIRP web site at <https://www.icnirp.org/cms/upload/publications/ICNIRPemfgdl.pdf> and Guidelines for Limiting Exposure to Time-Varying Electric, Magnetic, and Electromagnetic Fields.

Power density exposure limit

Install the radios for the 60 GHz cnWave™ platform family of wireless solutions so as to provide and maintain the minimum separation distances from all persons.

The applicable FCC power density exposure limit for RF energy in the 57 – 66 GHz frequency bands is 10 W/m². For more information, see [Human exposure to radio frequency energy](#).

Calculation of power density

The following calculation is based on the ANSI IEEE C95.1-1991 method, as that provides a worst case analysis.

Peak power density in the far field of a radio frequency point source is calculated as follows:

$$S = \frac{P \cdot G}{4\pi d^2}$$

Where:

S: power density in W/m²

p: maximum average transmit power capability of the radio, in W

G: total Tx gain as a factor, converted from dB

d: distance from point source, in m

Rearranging terms to solve for distance yields:

$$d = \sqrt{\frac{P \cdot G}{4\pi S}}$$

Calculated distances and power compliance margins

The following table displays recommended calculated separation distances, for the 60 GHz cnWave™ for Europe the USA and Canada. These are conservative distances that include compliance margins.



Note

Les tableaux suivants indiquent les distances de séparation recommandées calculées pour le cnWave™ 60 GHz pour l'Europe, les États-Unis et le Canada. Ce sont des distances prudentes qui incluent des marges de conformité.

At these and greater separation distances, the power density from the RF field is below generally accepted limits for the general population.



Note

À ces distances de séparation et à des distances supérieures, la densité de puissance du champ RF est inférieure aux limites généralement acceptées pour la population générale.

60 GHz cnWave™ Platform Family ODU adheres to all applicable EIRP limits for transmit power when operating in MIMO mode. Separation distances and compliance margins include compensation for the antenna configuration of each product.



Note

L'ODU de la famille de plates-formes cnWave™ 60 GHz respecte toutes les limites EIRP applicables pour la puissance de transmission lors d'un fonctionnement en mode MIMO. Les distances de séparation et les marges de conformité incluent la compensation de la configuration d'antenne de chaque produit.

Table 31: Calculated distances and power compliance margins

Product	Countries	EIRP (dBm)	EIRP (W)	Maximum power density (W/m ²)	Compliance distance (m)
V1000	USA, Canada, EU	38	6.3	10	0.22
V3000	USA, Canada	60.5	1122	10	3.0
V3000	EU	55	316.2	10	1.6
V5000	USA, Canada, EU	38	6.3	10	0.22



Note

The regulations require that the power used for the calculations is the maximum power in the transmit burst subject to allowance for source-based time-averaging.

The calculations above are based upon platform maximum EIRP and worst case 100% duty cycle.



Remarque

Les réglementations exigent que la puissance utilisée pour les calculs soit la puissance maximale de la rafale d'émission sous réserve de la moyenne temporelle basée sur la source.

Les calculs ci-dessus sont basés sur la PIRE maximale de la plate-forme et le pire des cas, un cycle de service de 100%.

Compliance with radio regulations

This section describes how the 60 GHz cnWave™ platform family complies with the radio regulations that are in force in various countries.



Caution

Where necessary, the end user is responsible for obtaining any national licenses required to operate this product and these must be obtained before using the product in any particular country. Contact the appropriate national administrations for details of the conditions of use for the bands in question and any exceptions that might apply.



Attention

Le cas échéant, l'utilisateur final est responsable de l'obtention des licences nationales nécessaires pour faire fonctionner ce produit. Celles-ci doivent être obtenus avant d'utiliser le produit dans un pays particulier. Contactez les administrations nationales concernées pour les détails des conditions d'utilisation des bandes en question, et toutes les exceptions qui pourraient s'appliquer.



Caution

Changes or modifications not expressly approved by Cambium Networks could void the user's authority to operate the system.



Attention
 Les changements ou modifications non expressément approuvés par les réseaux de Cambium pourraient annuler l'autorité de l'utilisateur à faire fonctionner le système.

Type approvals

The system is tested against various local technical regulations and found to comply. [Radio specifications](#) section list the radio specification type approvals that is granted for the 60GHz cnWave products.

Some of the frequency bands in which the system operates are “license exempt” and the system is allowed to be used provided it does not cause interference. In these bands, the licensing authority does not guarantee protection against interference from other products and installations.

Region	Regulatory approvals	FCC ID	IC ID
USA	Part 15C	QWP-60V1000 QWP-60V3000 QWP-60V5000	
Canada	ISED RSS-210		109AO-60V1000 109AO-60V3000 109AO-60V5000

FCC compliance

The 60 GHz cnWave™ V1000, V3000 and V5000 comply with the regulations that are in force in the USA.



Caution
 If this equipment does cause interference to radio or television reception.

FCC notification

This device complies with part 15C of the US FCC Rules. Operation is subject to the following two conditions: (1) This device may not cause harmful interference, and (2) This device must accept any interference received, including interference that may cause undesired operation.

ISED compliance

The 60 GHz cnWave™ V1000, V3000 and V5000 comply with the regulations that are in force in the Canada.



Caution
 If this equipment does cause interference to radio or television reception.



Attention

Si cet équipement cause des interférences à la réception radio ou télévision.

60 GHz cnWave™ example product labels











<p>Model No/HVIN:V5000  Part No:C600500A004A  SERIAL NO (MSN):#####  MAC (ESN):##### </p>	 <p>Cambium Networks™ Ashburton, TQ13 7UP, UK 60GHz cnWave V5000 Distribution Node</p> <p>VIN: 42.5-57V  IMAX: 1.41A</p> <p>E112443 COMPLIES WITH UL62368-1 / CSA C22.2 No. 62368-1-14 UL60950-22 / CSA C22.2 No. 60950-22-17</p> 	<p>IP66/67</p>
<p>This device complies with part 15 of the FCC Rules. Operation is subject to the following two conditions: (1) This device may not cause harmful interference, and (2) this device must accept any interference received, including interference that may cause undesired operation</p> <p>IMPORTANT: See the System User Guide before connecting to AC Power. The Guide is available online at www.cambiumnetworks.com/guides</p> <p>MADE IN CHINA X-SZHO-H</p>	<p>FCC ID: QWP-60V5000 IC: 109AO-60V5000</p>   	

Figure 1: 60 GHz cnWave™ V5000 Distribution Node











<p>Model No/HVIN:V3000  Part No:C600500C024A  SERIAL NO (MSN):#####  MAC (ESN):##### </p>	 <p>Cambium Networks™ Ashburton, TQ13 7UP, UK 60GHz cnWave V3000 Client Node Radio Only</p> <p>VIN: 42.5-57V  IMAX:1.29A</p> <p>E112443 COMPLIES WITH UL62368-1 / CSA C22.2 No. 62368-1-14 UL60950-22 / CSA C22.2 No. 60950-22-17</p> 	<p>IP66/67</p>
<p>This device complies with part 15 of the FCC Rules. Operation is subject to the following two conditions: (1) This device may not cause harmful interference, and (2) this device must accept any interference received, including interference that may cause undesired operation</p> <p>IMPORTANT: See the System User Guide before connecting to AC Power. The Guide is available online at www.cambiumnetworks.com/guides</p> <p>MADE IN CHINA X-SZHO-H</p>	<p>FCC ID: QWP-60V3000 IC: 109AO-60V3000</p>   	

Figure 2: 60 GHz cnWave™ V3000 Client Node Radio only

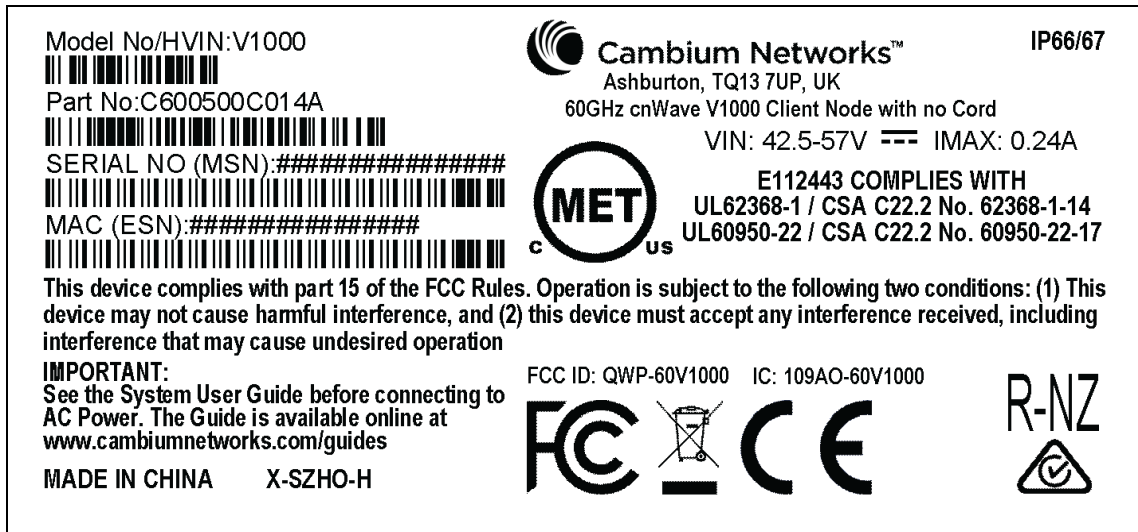

Figure 3: 60 GHz cnWave™ V1000 Client Node with no cord

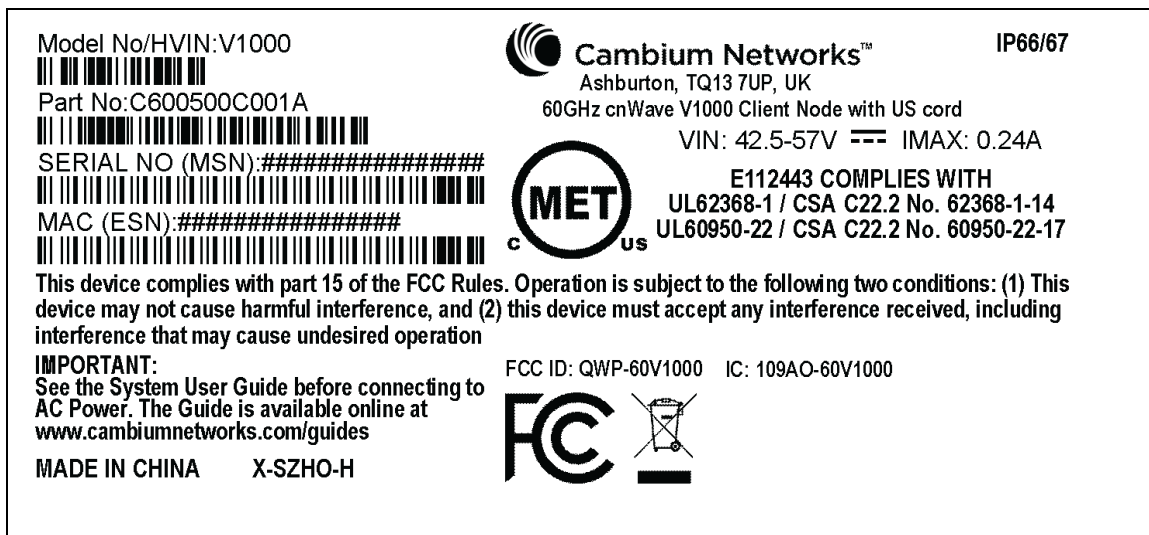

Figure 4: 60 GHz cnWave™ V1000 with US cord

Accessories	Radio nodes	Cambium Part Number
60 GHz cnWave™ V5000 Distribution Node	V5000	C6000500A004A
60 GHz cnWave™ V3000 Client Node radio only	V3000	C600500C024A
60 GHz cnWave™ V1000 Client Node with no cord	V1000	C600500C14A
60 GHz cnWave™ V1000 with US cord	V1000	C600500C001A

Chapter 9: Troubleshooting

This section describes the troubleshooting steps and addresses frequently asked questions related to 60 GHz cnWave™ product deployment.

- [Field diagnostics logs](#)
- [Setup issues in IPv4 tunneling](#)
- [Link is not established](#)
- [PoP not online](#)
- [Link is not coming up](#)
- [Link is not having expected throughput performance](#)
- [Factory reset](#)

Field diagnostics logs

Download the logs to view more information about the error. To download the error logs select the node from the drop-down and click **Download Logs**.

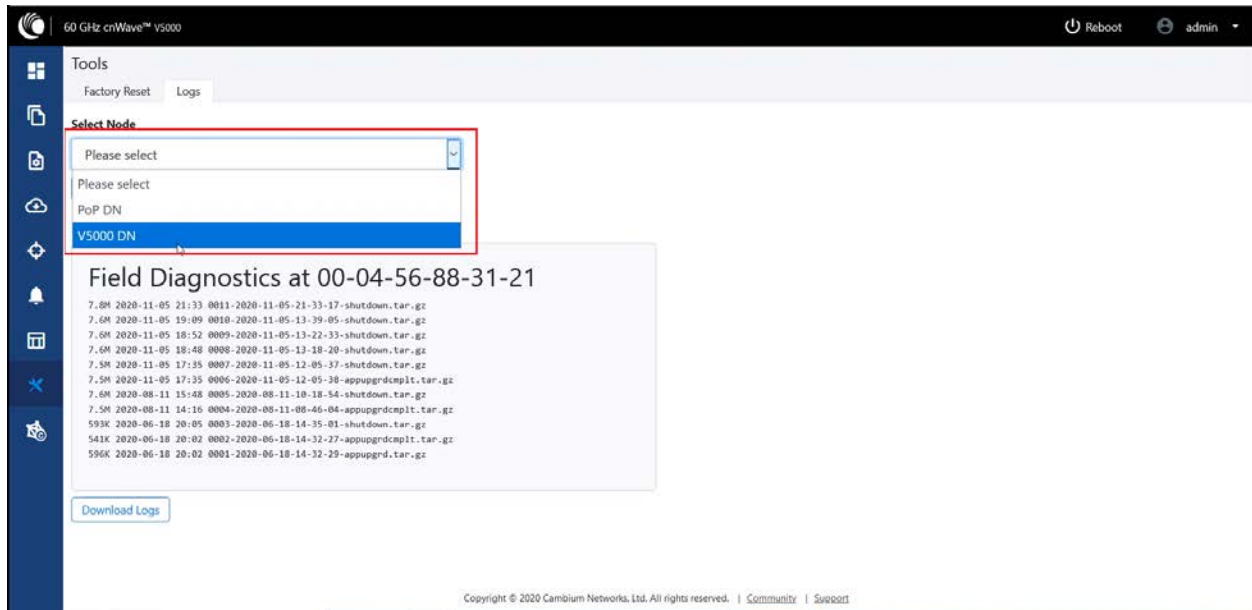

After clicking **Download Logs**, downloading status is displayed.

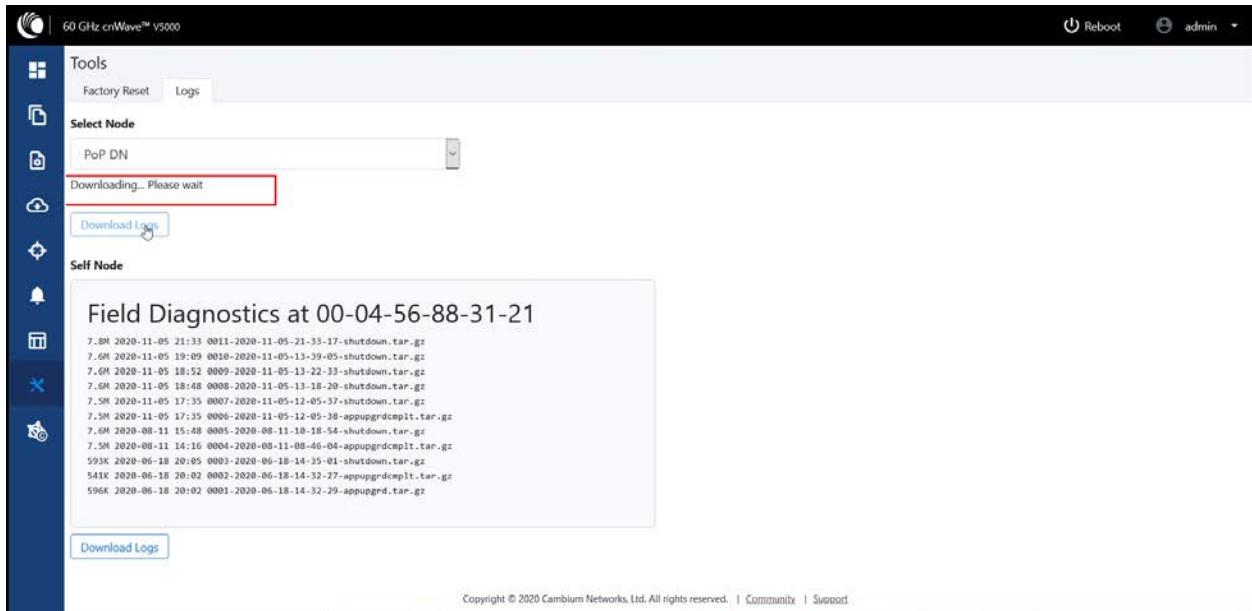

To download the logs for self node, click **Download Logs** at the bottom and save the log file.

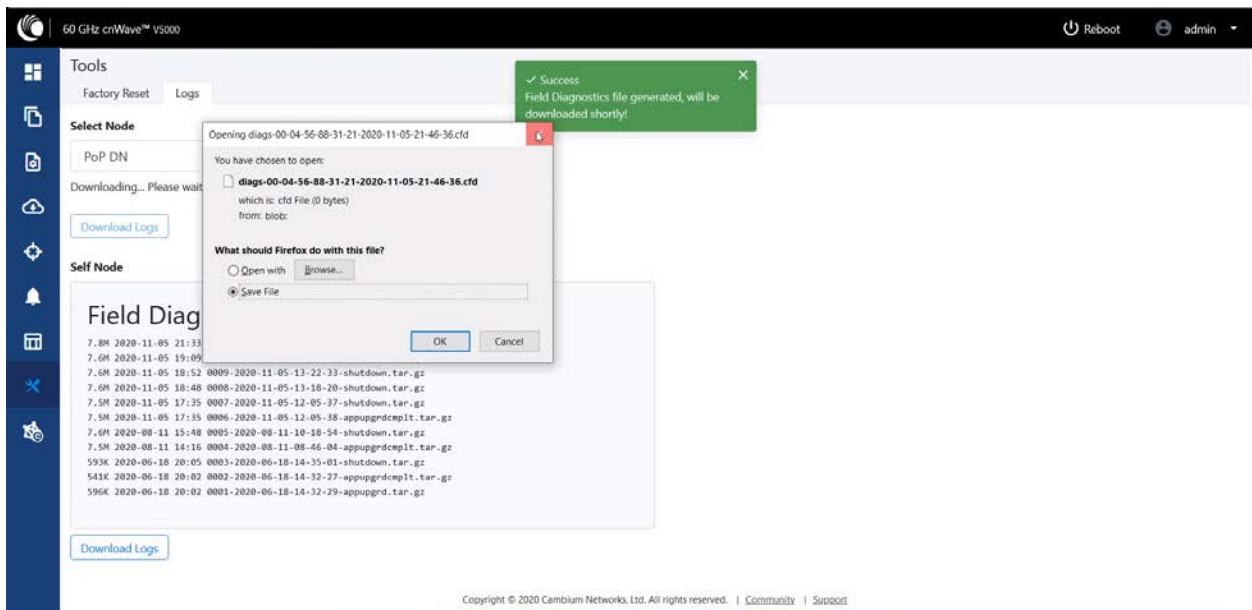

Setup issues in IPv4 tunneling

In IPv4 tunneling, if setup issues occurs then perform the below steps:

1. Click **Configuration** on the left pane, navigate to **Network > Basic > Layer 2 Bridge** and verify **Enable Layer 2 bridge** is selected.

60 GHz cnWave™ V3000

Configuration

Network Nodes

Basic Management Security Advanced

Layer 2 Bridge

Enable Layer 2 bridge

By selecting this checkbox, you will be enabling Layer 2 network bridging (via automatically created tunnels) across all nodes connected to a PoP. This will facilitate bridging of IPv4 traffic across the wireless networks.

Tunnel Concentrator

Best PoP Static

Prefix Allocation

Centralized Deterministic

Seed Prefix

Generate

IPv6 'seed prefix' in CIDR format from which subnet prefixes are allocated to all DNs and CNs (e.g. face:b00c:cafe:ba00::/56)

Prefix Length

Length of per-node allocated prefixes

2. On the same page under **Configuration Management**, verify **E2E Managed Config** is selected.

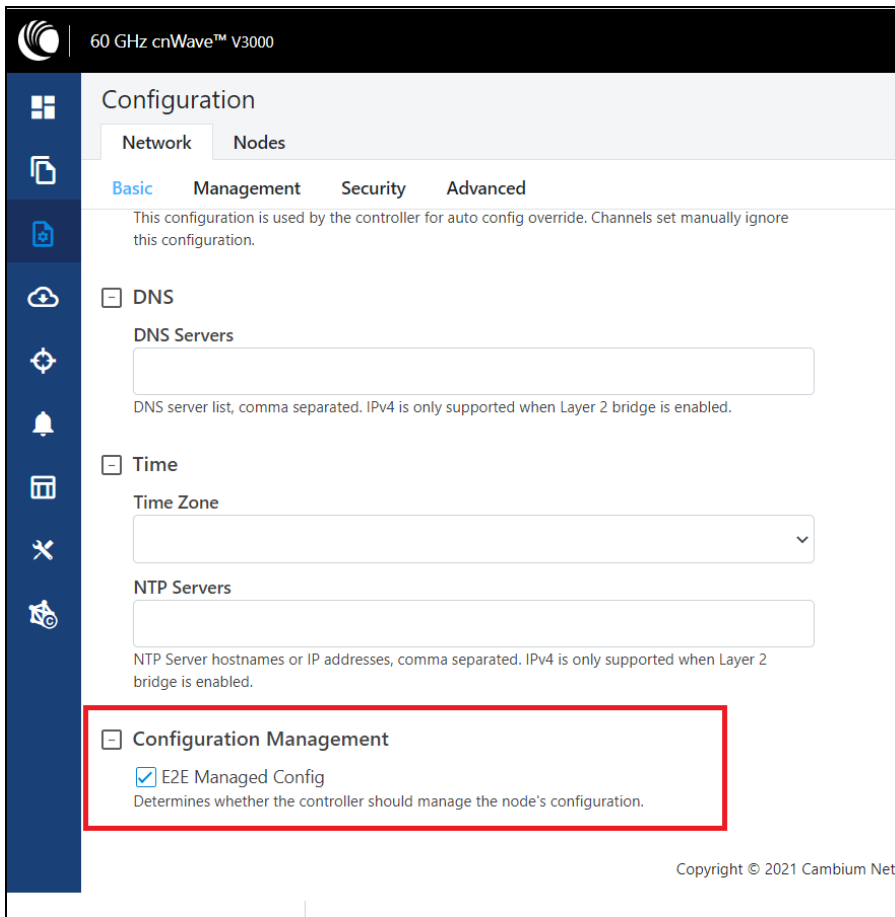

3. Click **Configuration > Nodes > PoP DN > Networking > Layer 2 Bridge** and verify **Disable Broadcast Flood** and **Disable IPv6** are disabled.

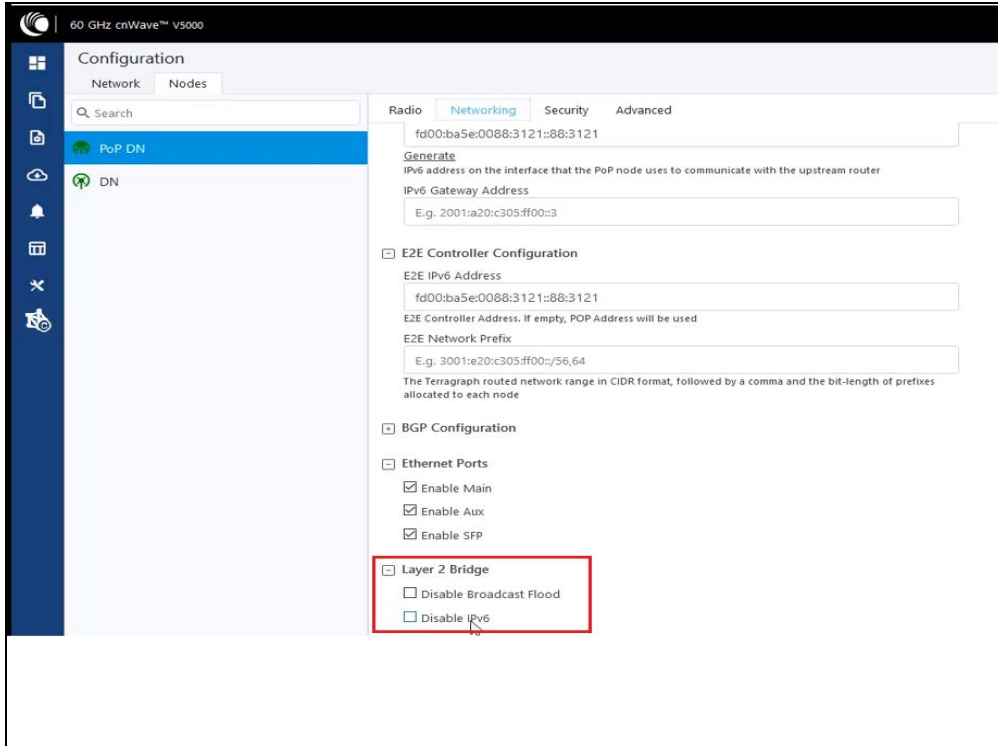

4. Ensure that PoP DN and DNs are in the same subnet and verify gateway is correct.

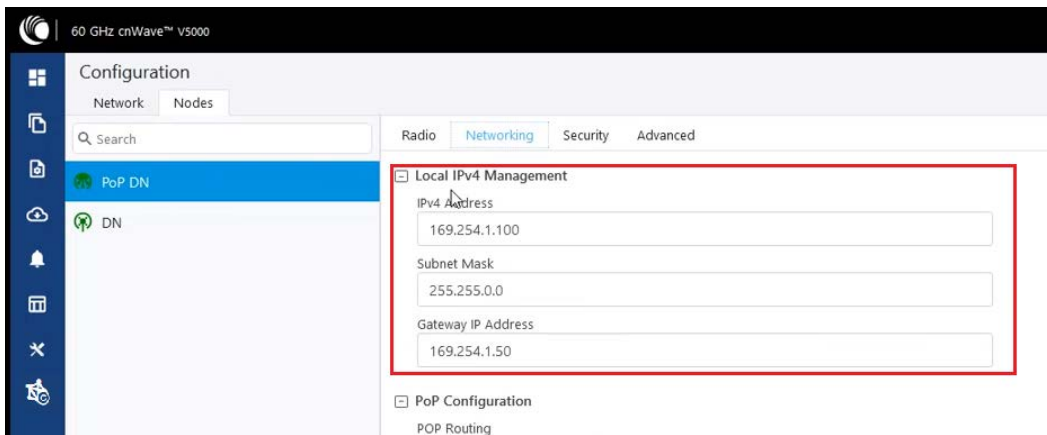

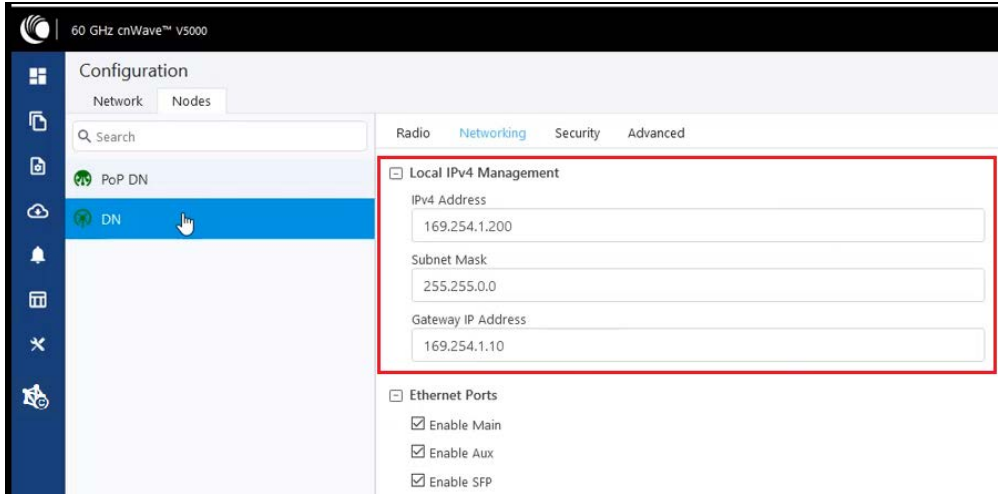

Link is not established

If link is not established between the nodes, then verify the below options:

1. Click **Configuration** on the left panel.
2. Navigate to **Nodes > Radio** and verify Sector 2 PoP DN and DN's polarities, frequency and Golay codes.

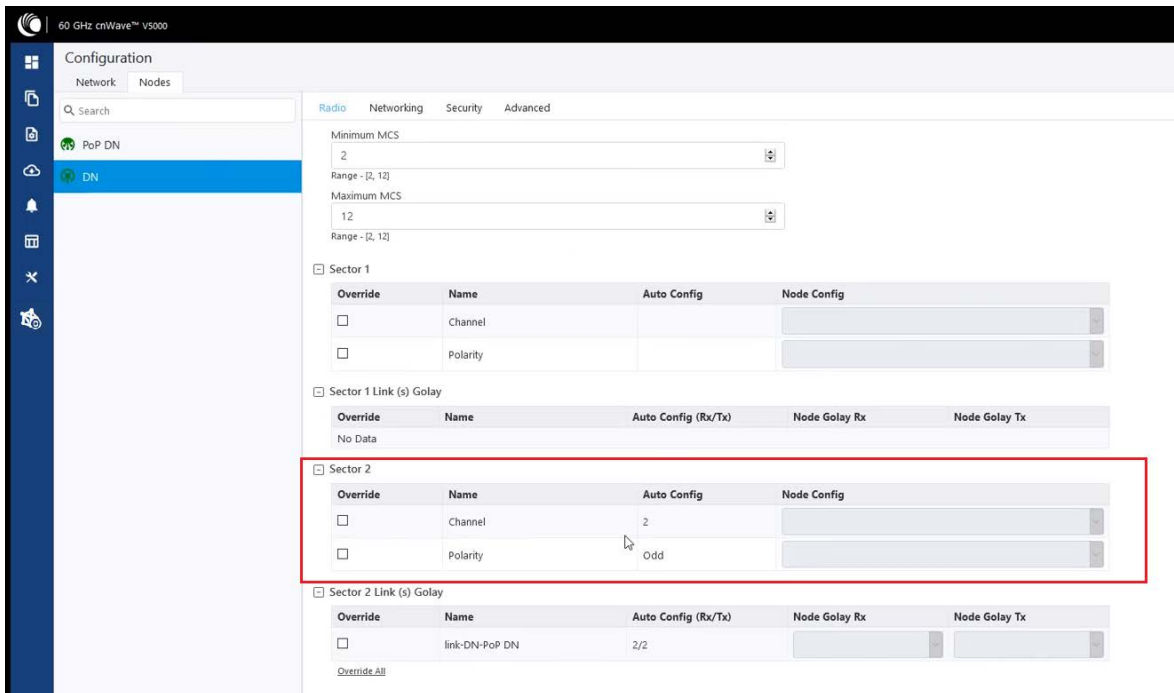

3. Select **DN > Networking > Ethernet Ports**, and ensure that specific Ethernet ports are enabled.

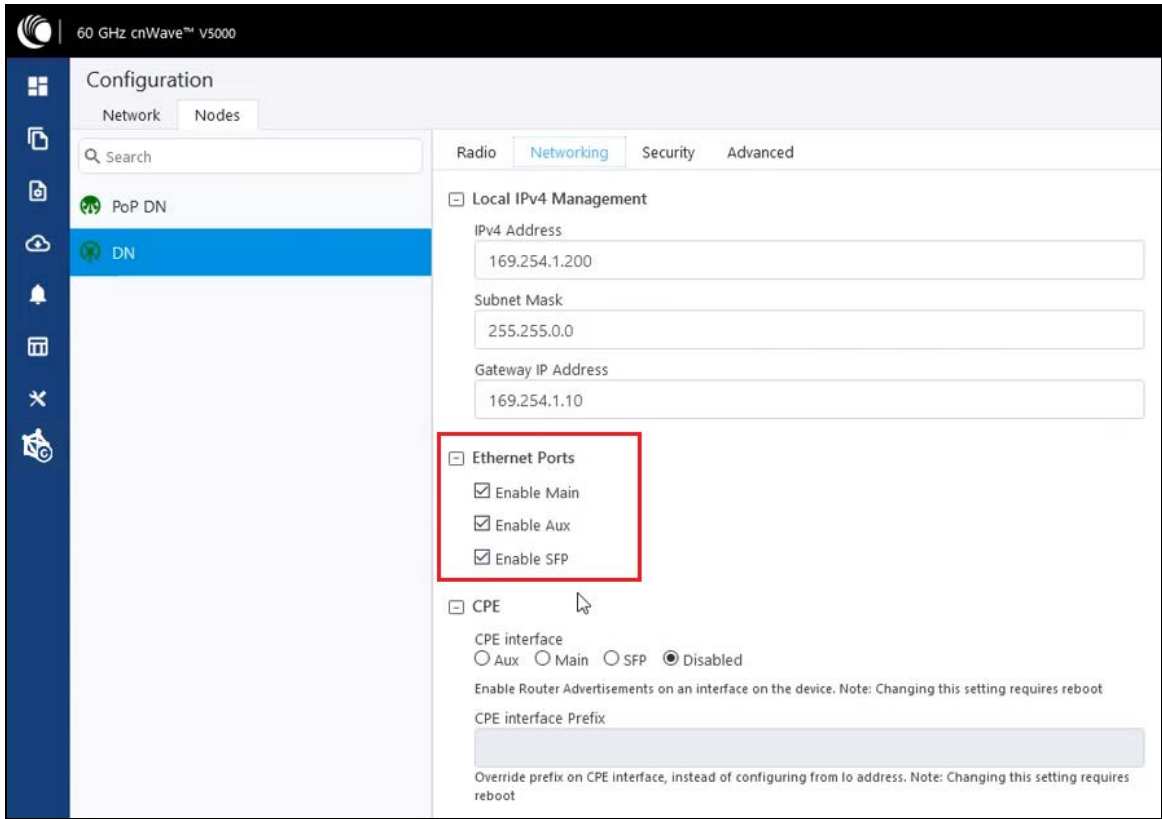

4. Click **Topology** on left pane, go to **Nodes** and verify Status is **Online Initiator**.

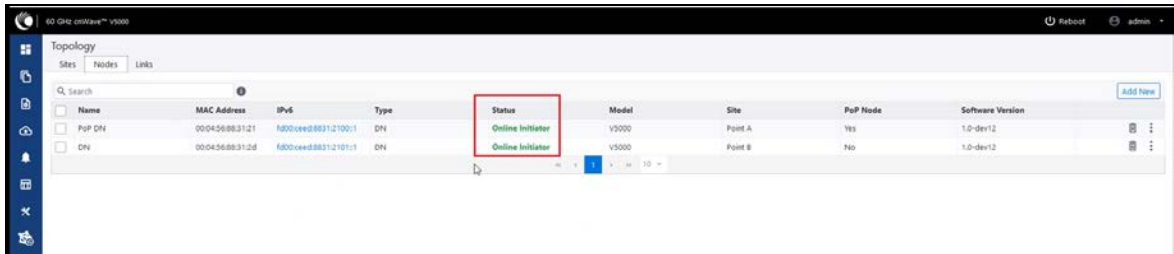

5. Click **Statistics** on left pane, go to **Links** and verify **RSSI, MCS, TX Power Index**.



- Go to **Performance** and verify the graphs.

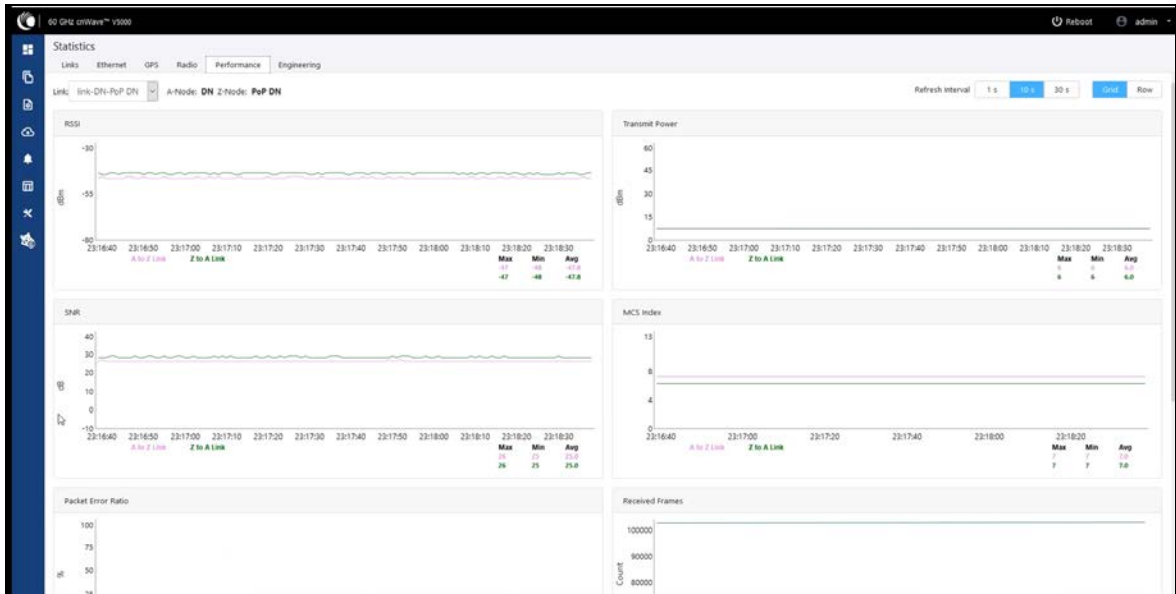

- Go to **Radio** and monitor the throughput capacity.

Device Name	MAC Address	Sync Mode	Channel	Security	Error Association	Channel Last State	RX Throughput	TX Throughput
Pop DN	120456883121	89	2	None	0	0	7.66 kbps	1.63 kbps
Pop DN	220456883121	89	1	None	0	0	0 kbps	0 kbps
DN	120456883120	89	1	None	0	0	0 kbps	0 kbps
DN	220456883120	89	2	None	0	0	0.69 kbps	4.66 kbps

- If internal GPS is used, then verify **Configuration > Nodes > Radio > GPS > Force GPS Disable** is enabled.

Configuration

Radio | Networking | Security | Advanced

Minimum MCS: 2
Range: (2, 12)

Maximum MCS: 12
Range: (2, 12)

Sector 1

Override	Name	Auto Config	Node Config
<input type="checkbox"/>	Channel	2	
<input type="checkbox"/>	Polarity	Even	

Sector 1 Link (s) Gofay

Override	Name	Auto Config (Rx/Tx)	Node Gofay Rx	Node Gofay Tx
<input type="checkbox"/>	link-DN-Pop-DN	2/2		

Sector 2

Override	Name	Auto Config	Node Config
<input type="checkbox"/>	Channel		
<input type="checkbox"/>	Polarity		

Sector 2 Link (s) Gofay

Override	Name	Auto Config (Rx/Tx)	Node Gofay Rx	Node Gofay Tx
No Data				

GPS

Force GPS Disable
When checked, the radio will use internal gps rather than GPS sync

PoP not online from E2E/cnMaestro GUI

This usually means that the PoP node is not able to talk to the E2E controller. Ensure that the PoP node has the E2E IPv6 configured properly. Also ensure that there is a route between the E2E controller and the PoP node, if they are not in the same VLAN. Try to ping the E2E from the PoP node (login to ssh).

Link is not coming up

1. Ensure that the two ends of the radios can see each other (clear line of sight in between). If the link is using V3000, ensure that they are properly aligned.
2. Ensure that MAC address of the radios are configured correctly in the E2E Controller.
3. Ensure that GPS sync is not enabled if indoor and ensure that GPS sync is enabled if outdoor.
4. Ensure that both ends of the link has the same software version.
5. Ensure to configure country code on the E2E GUI.
6. Ensure that the two ends of the link use opposite polarity and Golay codes that matches each other.
7. Ensure that the remote ends can reach the E2E Controller – IPv6 configuration (if beamforming is successful but the remote end cannot reach back to the E2E Controller, the E2E Controller/cnMaestro GUI displays link status as up but the remote radio is offline).
8. If you already have experience setting up a link and you are trying to setup a daisy chain, ensure that there is not any interference caused by the existing link. For example, make sure that the two neighboring link use different Golay code.

Link does not come up after some configuration change

There is a possibility that the remote unit could be in a state that it uses different channel/Golay code/polarity from the near-end unit. Try to factory default the remote radio if possible.

On the E2E Controller/cnMaestro, it shows that the link is up, but the remote radio is NOT online - This means that link is established but the remote end radio cannot reply back to the E2E Controller. Check the E2E configuration to make sure that the IPv6 default gateway is configured correctly to allow a route between the E2E controller and the remote radio.

Link is not having expected throughput performance

- Check the radio GUI to ensure that the link is running as the expected MCS mode when user data is passing through.
- Check to ensure that the Ethernet ports of the radios and the testing devices are negotiated to expected data rate (10Gbps).
- Ensure that your testing devices are capable of handling the throughput – run data throughput test by bypassing the radio link.
- Do not use radio internal iperf tool to test throughput.

Factory reset

Recovery mode is used to reset the configuration to the factory settings. To reset the configuration, perform the following steps:

1. Go to **Tools** menu and click **Factory Reset**.

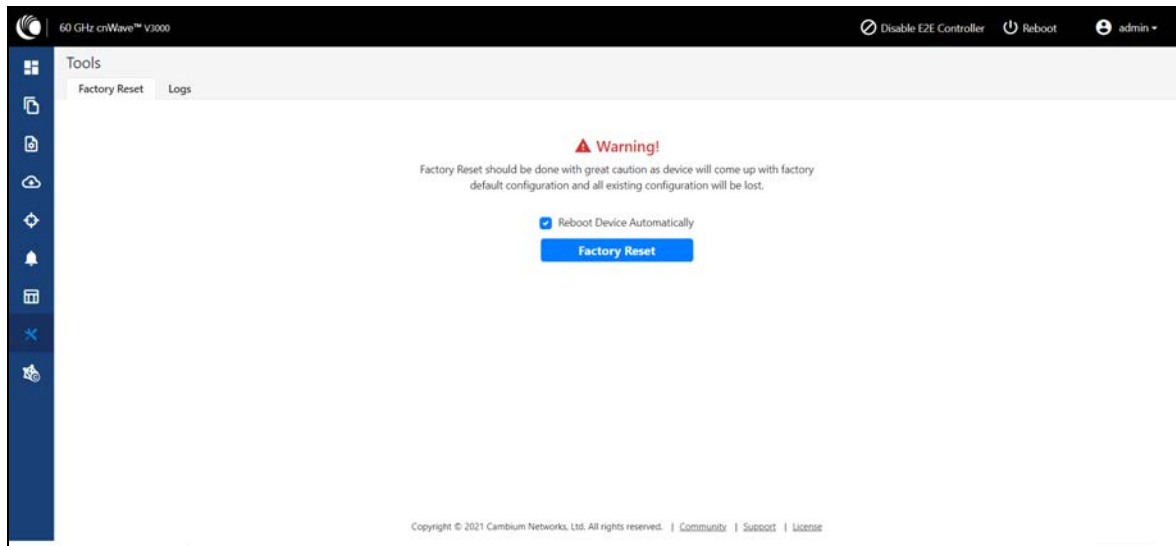

Pop-up appears. Confirm to reset the device to factory reset

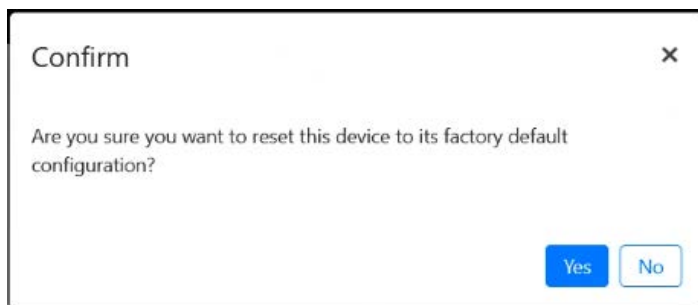

2. Click **Yes** to reboot.
3. After the reboot, access the device using IP address **169.254.1.1**.



Note

After factory reset, all configuration set to default mode.

Cambium Networks

Cambium Networks provides professional grade fixed wireless broadband and microwave solutions for customers around the world. Our solutions are deployed in thousands of networks in over 153 countries, with our innovative technologies providing reliable, secure, cost-effective connectivity that's easy to deploy and proven to deliver outstanding performance.

Our award-winning Point to Point (PTP) radio solutions operate in licensed, unlicensed and defined use frequency bands including specific FIPS 140-2 solutions for the U.S. Federal market. Ruggedized for 99.999% availability, our PTP solutions have an impeccable track record for delivering reliable high-speed backhaul connectivity even in the most challenging non-line-of-sight RF environments.

Our flexible Point-to-Multipoint (PMP) solutions operate in the licensed, unlicensed and federal frequency bands, providing reliable, secure, cost-effective access networks. With more than three million modules deployed in networks around the world, our PMP access network solutions prove themselves day-in and day-out in residential access, leased line replacement, video surveillance and smart grid infrastructure applications.

Cambium Networks solutions are proven, respected leaders in the wireless broadband industry. We design, deploy and deliver innovative data, voice and video connectivity solutions that enable and ensure the communications of life, empowering personal, commercial and community growth virtually everywhere in the world.

User Guides	http://www.cambiumnetworks.com/guides
Technical training	https://learning.cambiumnetworks.com
Support website	https://support.cambiumnetworks.com
Main website	http://www.cambiumnetworks.com
Sales enquiries	solutions@cambiumnetworks.com
Support enquiries	https://support.cambiumnetworks.com
Telephone number list	http://www.cambiumnetworks.com/contact-us/
Address	Cambium Networks Limited, Linhay Business Park, Eastern Road, Ashburton, Devon, TQ13 7UP United Kingdom



www.cambiumnetworks.com

Cambium Networks and the stylized circular logo are trademarks of Cambium Networks, Ltd. All other trademarks are the property of their respective owners.

© Copyright 2021 Cambium Networks, Ltd. All rights reserved.