

DS-1705ZJ-DM35

Wall Mounting Bracket for Anti-Crossion Dome Camera



Feature

- That the bracket is formed by one piece stainless steel ensures the reliable structure
- Anti-corrosion material: 316L stainless steel
- Applicable for coastal area, vessel, chemical factory, etc.

Dimension

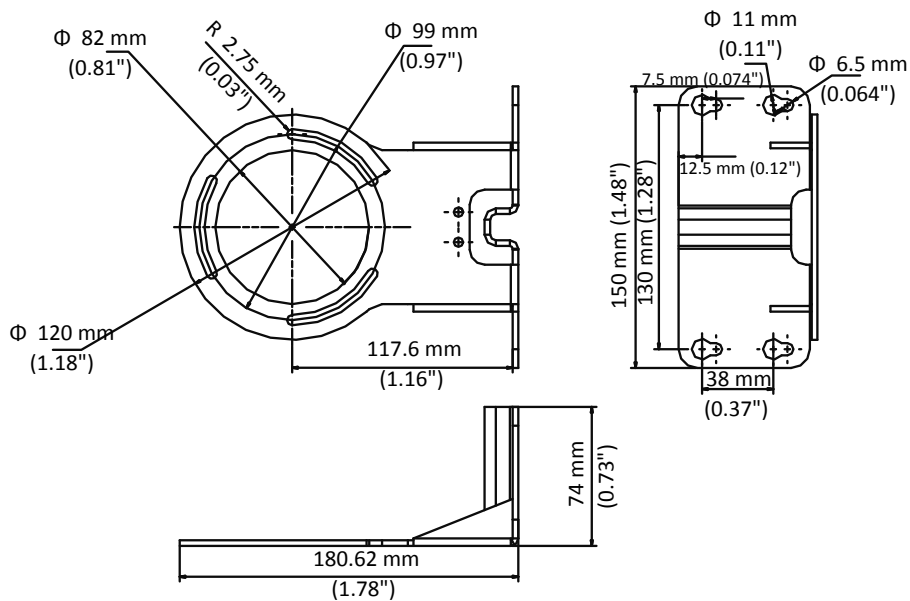

Available Model

DS-1705ZJ-DM35

Parameter

Model	DS-1705ZJ-DM35
Parameters	Wall Mounting Bracket for Anti-Corrosion Dome Camera
Appearance	Natural Stainless Steel Color
Material	316L Stainless Steel
Dimension	$\Phi 180.6\text{ mm} \times 150\text{ mm} \times 74\text{ mm}$ (1.78" \times 1.48" \times 0.73")
Weight	498 g (1.1 lb.)

Note

- The bracket should be installed on the flat surface.
- The waterproof rubber is necessary for the outdoor application.
- The wall must be capable of supporting at least 3 times as much as the total weight of the camera and the bracket.
- The bracket's maximum load capacity is 3 KG (6.6 lb.).